

# Montageanleitung | Instructions de montage Assembly Instructions | Instrucciones de montaje

SKU NUMBER: N601P452342 N601P452343

90\*190cm

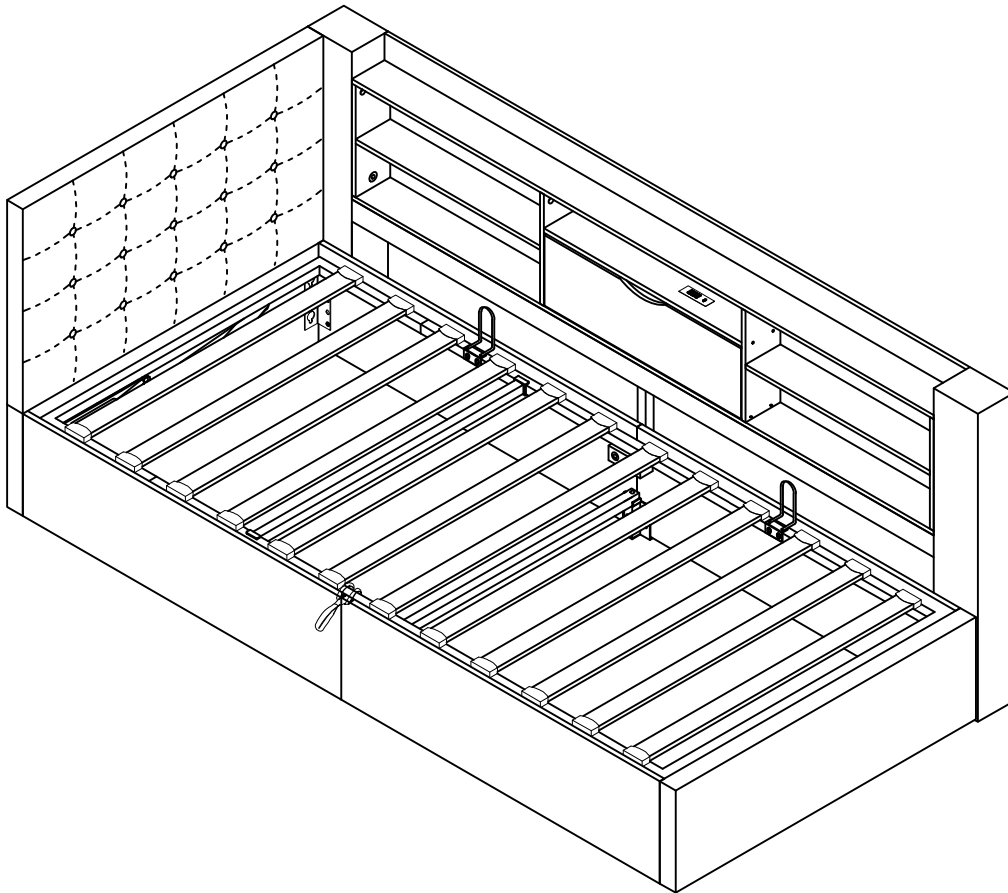

This set comes in 2 boxes. If you do not receive a full set of 2 boxes, please contact our customer service.



Dieses Set wird in 2 Schachteln geliefert. Wenn Sie nicht ein komplettes Set von 2 Boxen erhalten, kontaktieren Sie bitte unseren Kundenservice.



Ce set est livré en 2 boîtes. Si vous ne recevez pas un jeu complet de 2 boîtes, veuillez contacter notre service clientèle.



FR

Cet appareil,  
ses cordons,  
et batterie  
se recyclent

À DÉPOSER  
EN MAGASIN



OU

À DÉPOSER  
EN DÉCHÈTERIE



Points de collecte sur [www.quefairedemesdechets.fr](http://www.quefairedemesdechets.fr)  
Privilégiez la réparation ou le don de votre appareil !

UK  
CA



## English

### IMPORTANT FOR GAS LIFT BEDS&MAINTAINCE

- Please place the mattress on top of the bed frame.
- Please do not pull on the strap handles.
- Please press heavily to release the compressed gas.
- Periodically check all screw & fixings to ensure they are secure.
- When moving your product, carefully lift into place.
- Wipe clean with a slightly damp cloth- please do not use abrasive chemicals or bleach.
- Do NOT allow children to operate the lift mechanism.
- Do NOT allow children near the lift base when operating the mechanism.
- Do NOT stand inside the bed or the internal storage base.
- Do NOT overload the internal storage base.
- DO NOT jump on the product or any of its parts.

## Deutsch

### WICHTIG FÜR GASLIFT-BETTEN&WARTUNG

- Bitte legen Sie die Matratze oben auf den Bettrahmen.
- Bitte ziehen Sie nicht an den Gurtgriffen.
- Bitte drücken Sie kräftig, um das komprimierte Gas freizusetzen.
- Überprüfen Sie regelmäßig alle Schrauben und Befestigungen, um sicherzustellen, dass sie sicher sind.
- Wenn Sie Ihr Produkt bewegen, heben Sie es vorsichtig an seinen Platz.
- Mit einem leicht feuchten Tuch abwischen - bitte keine scheuernden Chemikalien oder Bleichmittel verwenden.
- Erlauben Sie Kindern NICHT, den Hebemechanismus zu bedienen.
- Lassen Sie Kinder NICHT in die Nähe des Liftsockels, wenn Sie den Mechanismus bedienen.
- Stellen Sie sich NICHT in das Bett oder in die Innenablage.
- Überlasten Sie den internen Liftsockel NICHT.
- Springen Sie NICHT auf das Produkt oder eines seiner Teile.

## Français

### IMPORTANT POUR LES LITS À RELEVAGE DE GAZ&MAINTENANCE

- Veuillez placer le matelas sur le dessus du cadre de lit.
- Ne tirez pas sur les poignées de la sangle.
- Appuyez fortement pour libérer le gaz comprimé.
- Vérifiez régulièrement que toutes les vis et fixations sont bien en place.
- Lorsque vous déplacez votre produit, soulevez-le avec précaution pour le mettre en place.
- Nettoyez avec un chiffon légèrement humide - n'utilisez pas de produits chimiques abrasifs ou d'eau de Javel.
- Ne laissez pas les enfants utiliser le mécanisme de levage.
- Ne laissez pas les enfants s'approcher de la base de levage lorsqu'ils actionnent le mécanisme.
- Ne vous tenez PAS à l'intérieur du lit ou de la base de stockage interne.
- Ne surchargez pas la base de stockage interne.
- Ne pas sauter sur le produit ou l'une de ses parties.

**Italiano**

**IMPORTANTE PER I LETTI CON SOLLEVAMENTO A GAS E LA MANUTENZIONE**

- Posizionare il materasso sopra la struttura del letto.
- Non tirare le maniglie della cinghia.
- Premere con forza per rilasciare il gas compresso.
- Controllare periodicamente tutte le viti e i fissaggi per assicurarsi che siano saldi.
- Quando si sposta il prodotto, sollevarlo con cautela.
- Pulire con un panno leggermente umido, senza usare prodotti chimici abrasivi o candeggina.
- NON permettere ai bambini di azionare il meccanismo di sollevamento.
- NON permettere ai bambini di avvicinarsi alla base di sollevamento quando si aziona il meccanismo.
- NON sostare all'interno del letto o della base di contenimento interna.
- NON sovraccaricare la base di contenimento interna.
- NON saltare sul prodotto o sulle sue parti.

**Español**

**IMPORTANTE PARA LAS CAMAS ELEVADORAS DE GAS&MANTENIMIENTO**

- Coloque el colchón sobre el somier.
- No tire de las asas de la correa.
- Presione con fuerza para liberar el gas comprimido.
- Compruebe periódicamente que todos los tornillos y fijaciones estén bien sujetos.
- Al mover el producto, levántelo con cuidado para colocarlo en su sitio.
- Limpie con un paño ligeramente humedecido; no utilice productos químicos abrasivos ni lejía.
- NO permita que los niños accionen el mecanismo de elevación.
- NO permita que los niños se acerquen a la base elevadora cuando accionen el mecanismo.
- NO se ponga de pie dentro de la cama o de la base de almacenamiento interna.
- NO sobrecargue el somier.
- NO salte sobre el producto ni sobre ninguna de sus piezas.

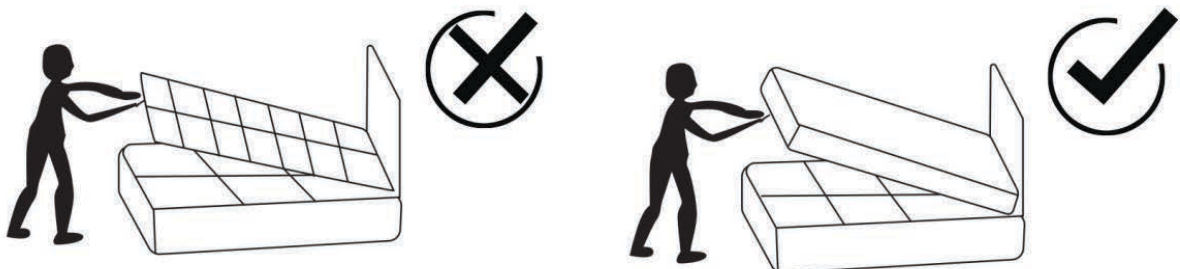

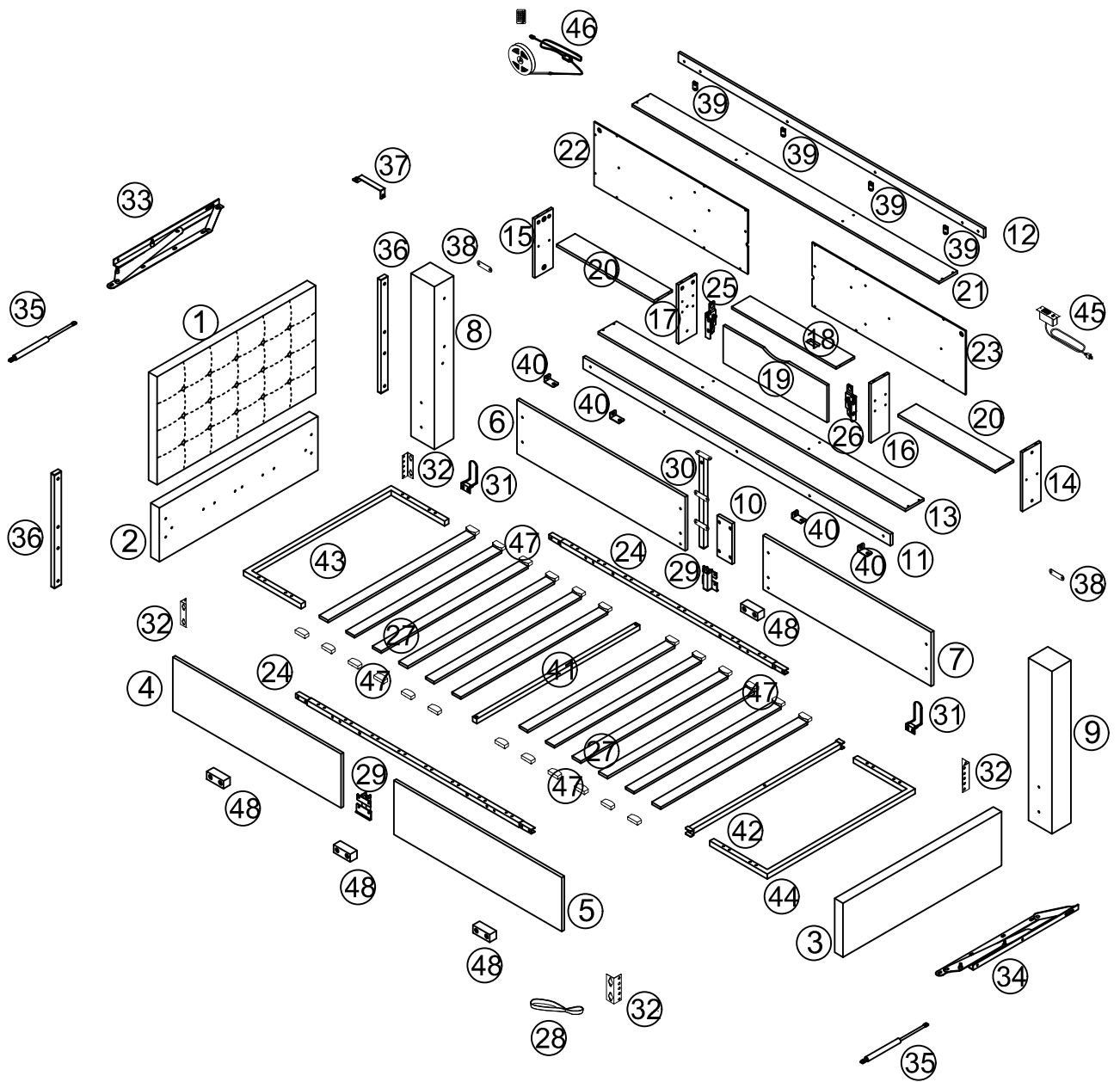

# N601P452342

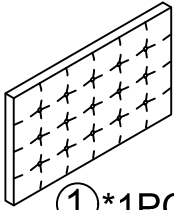

①\*1PC



②\*1PC

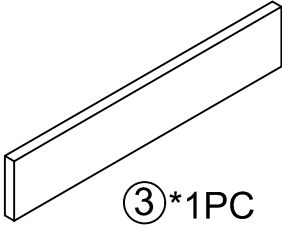

③\*1PC

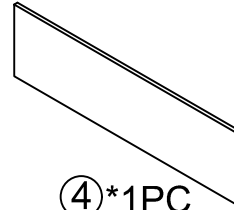

④\*1PC

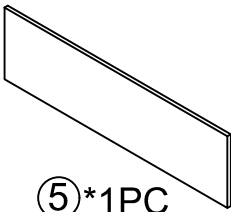

⑤\*1PC

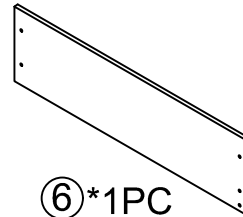

⑥\*1PC

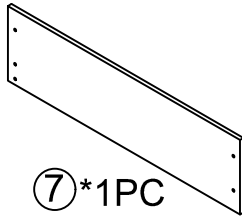

⑦\*1PC

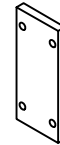

⑩\*1PC

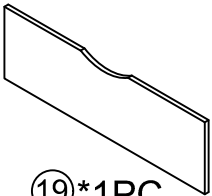

⑱\*1PC

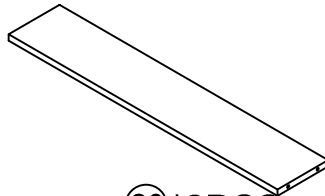

⑳\*2PCS

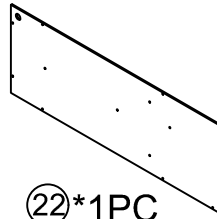

㉒\*1PC

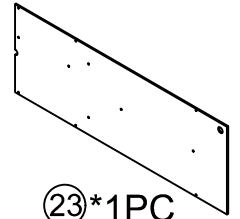

㉓\*1PC



㉕\*1PC



㉖\*1PC



㉘\*1PC



㉙\*2PCS

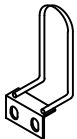

㉛\*2PCS



㉜\*4PCS



㉟\*1PC



㉠\*2PCS



㉣\*4PCS



㉤\*4PCS

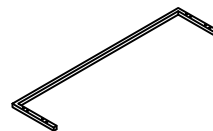

㉧\*1PC

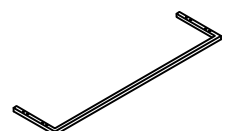

㉨\*1PC

# N601P452343

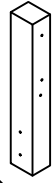

⑧\*1PC



⑨\*1PC

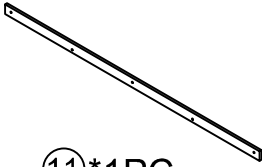

⑪\*1PC

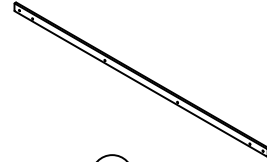

⑫\*1PC

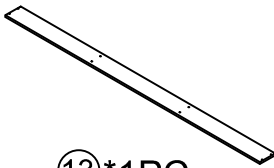

⑬\*1PC



⑭\*1PC



⑮\*1PC

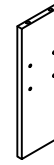

⑯\*1PC

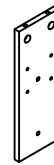

⑰\*1PC

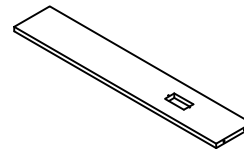

⑱\*1PC

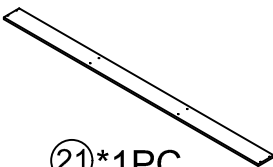

⑳\*1PC

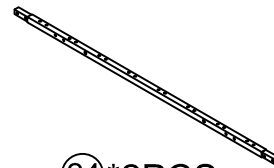

㉔\*2PCS

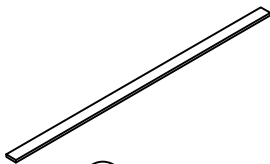

㉗\*12PCS

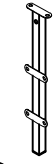

㉓\*1PC

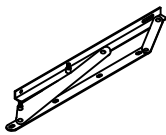

㉓\*1PC

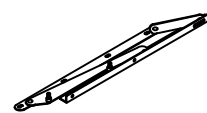

㉔\*1PC

# N601P452343

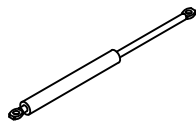

③⑤\*2PCS

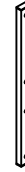

③⑥\*2PCS

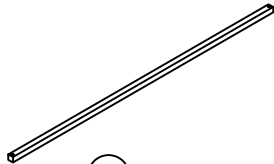

④①\*1PC

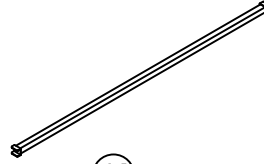

④②\*1PC

# N601P452342



④⑤\*1PC



④⑥\*1PC

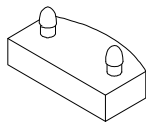

④⑦\*24PCS

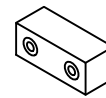

④⑧\*4PCS

# Hardware List-Hardwareliste N601P452342

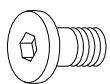

M8×10 mm  
A\*18PCS

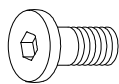

M8×16 mm  
B\*56PCS

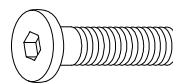

M8×40 mm  
C\*29PCS

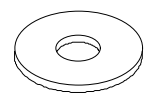

Ø8×22 mm  
D\*12PCS



M5×40 mm  
E\*48PCS



36 mm  
F\*8PCS

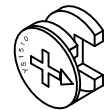

Ø15 mm  
G\*8PCS

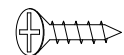

M3×10 mm  
H\*2PCS



M8  
I\*4PCS

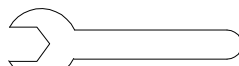

M8 Spanner  
J\*1PC

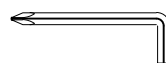

S5  
K\*1PC



S3  
L\*1PC

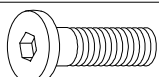

M8×32 mm  
M\*4PCS



Spanner  
N\*1PC



decorative tape  
U\*1PC

L:

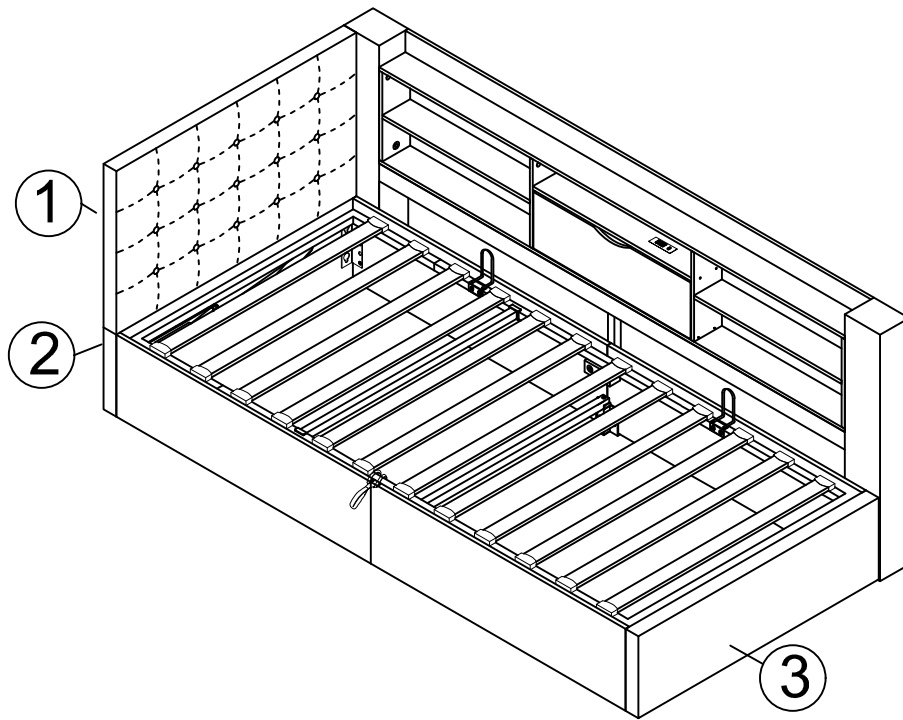

R:

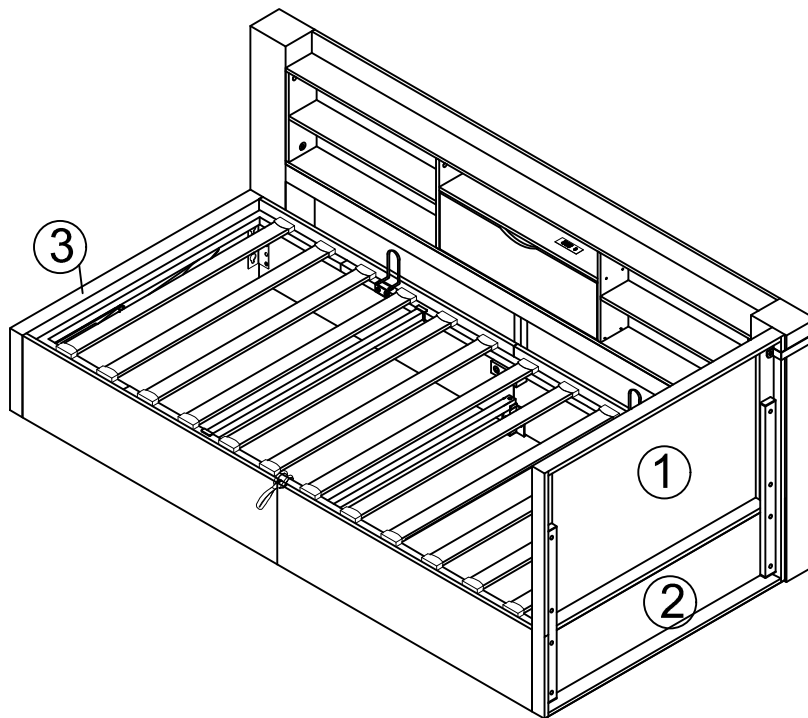

**1** N\*2  
M3×12

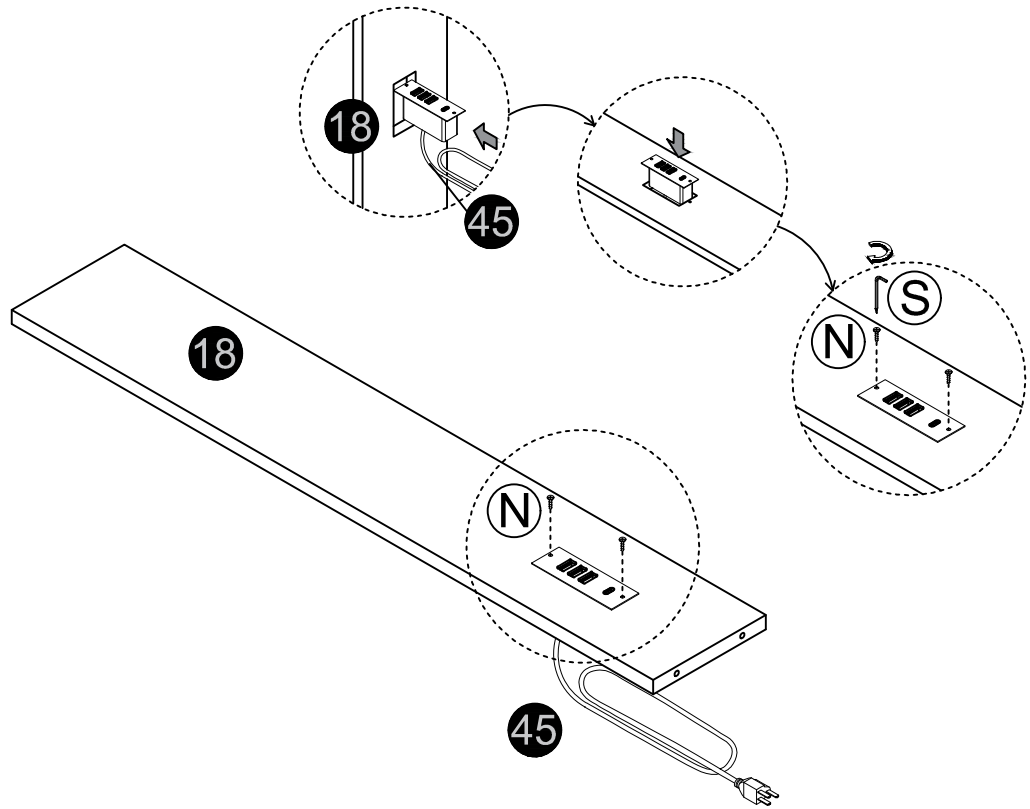

**2** K\*4  
M5×40

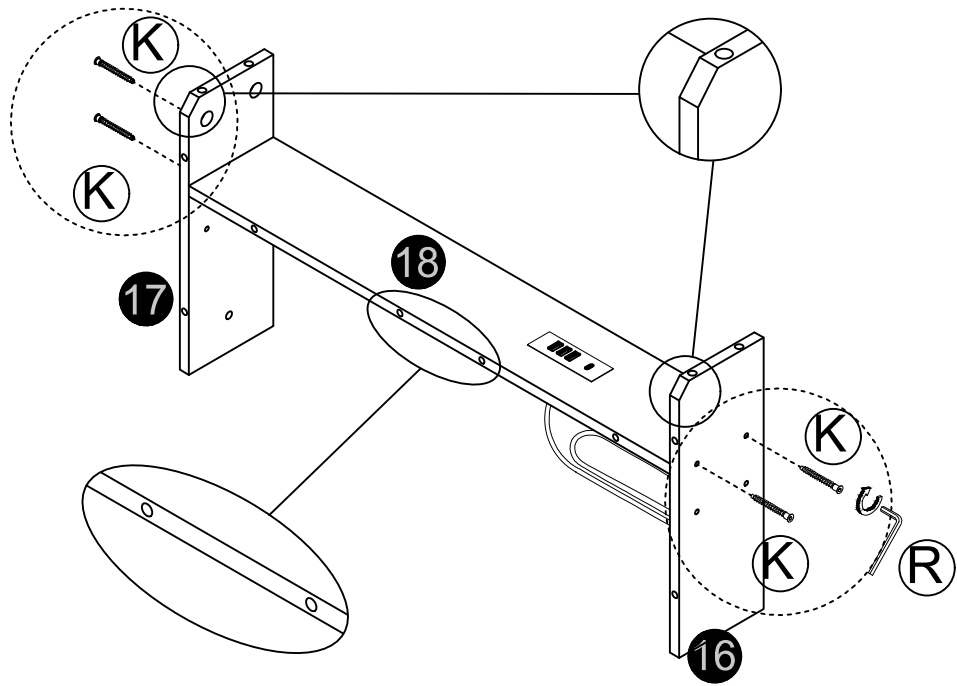

**3** E\*4  
M5×40

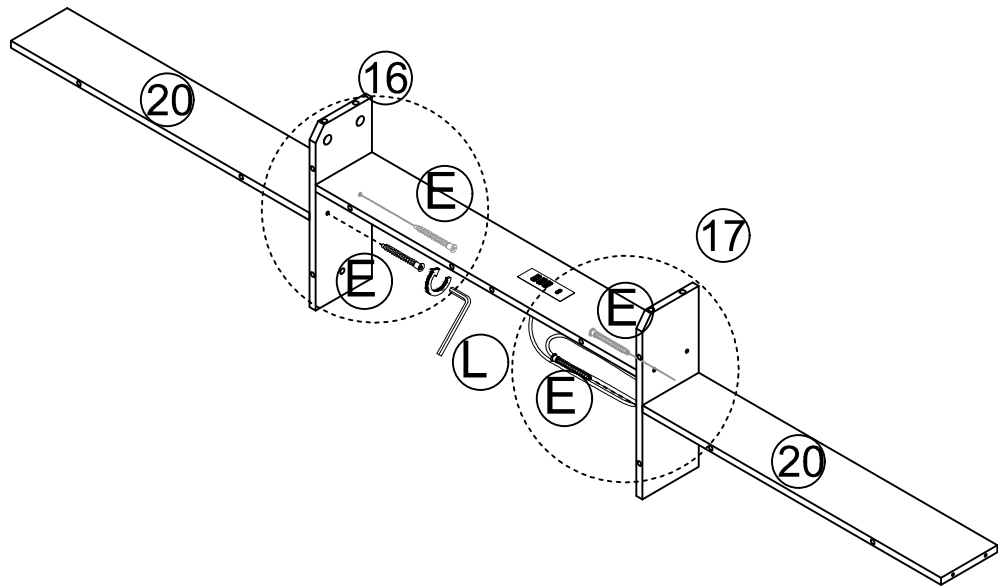

**4** E\*4  
M5×40

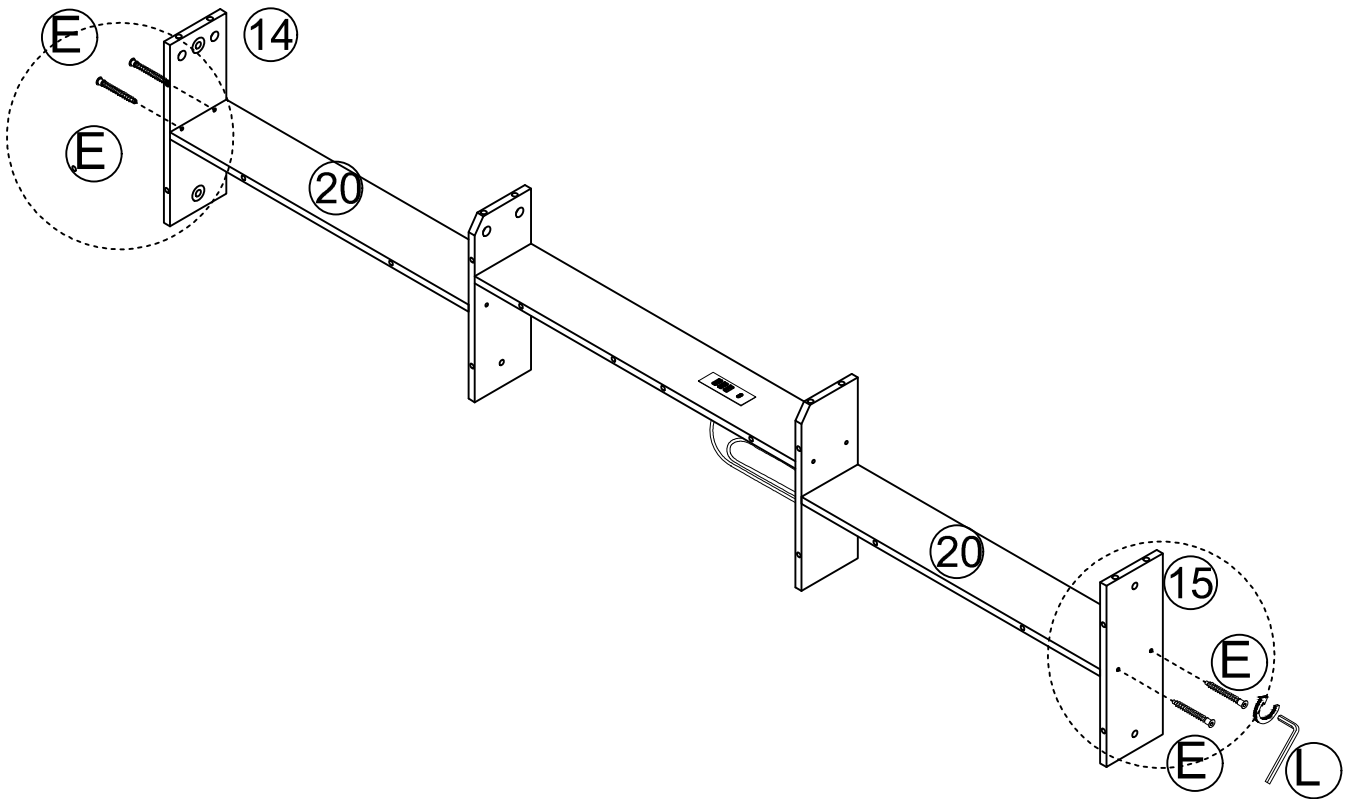

**5** F\*8  
36MM

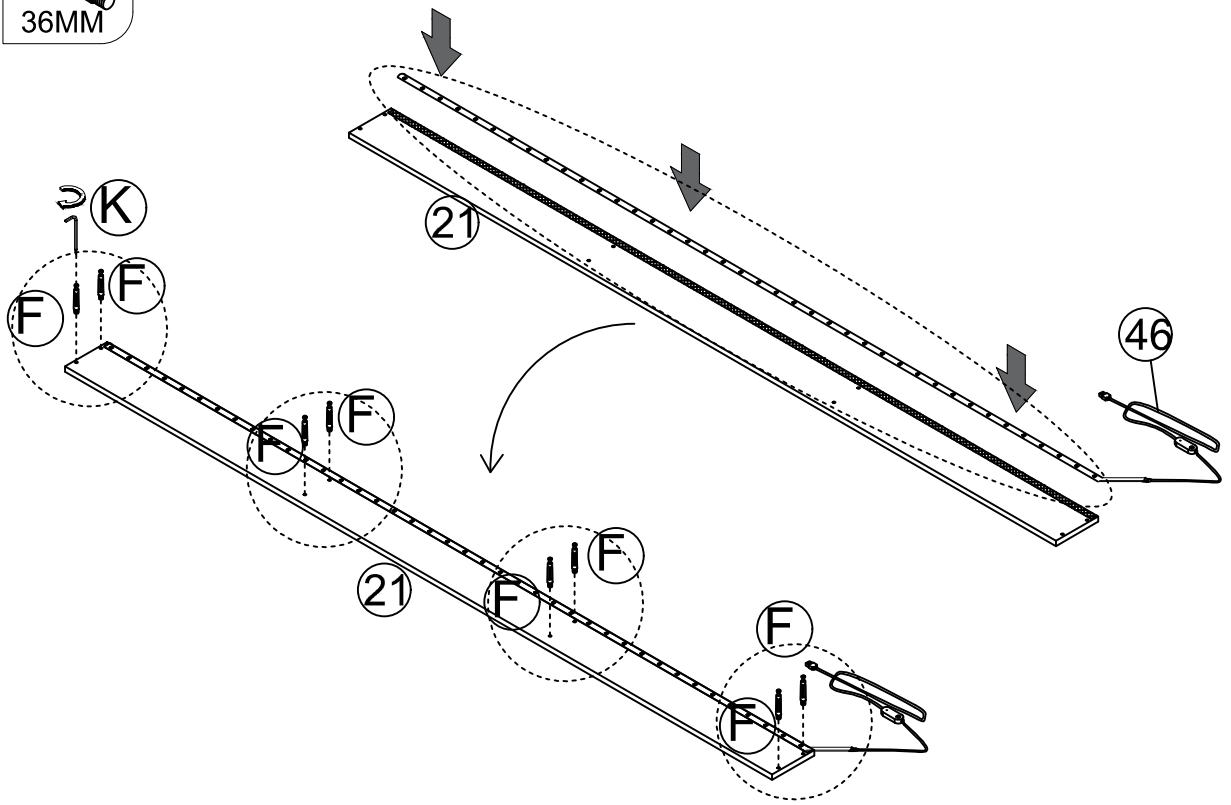

**6** G\*8  
Ø15MM

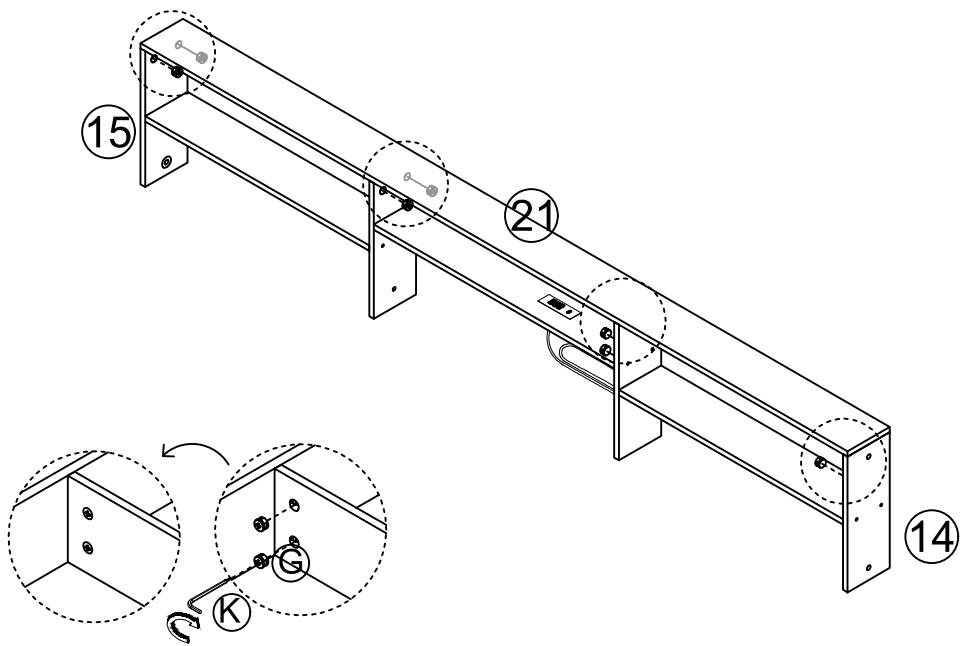

**7** E\*8  
M5×40

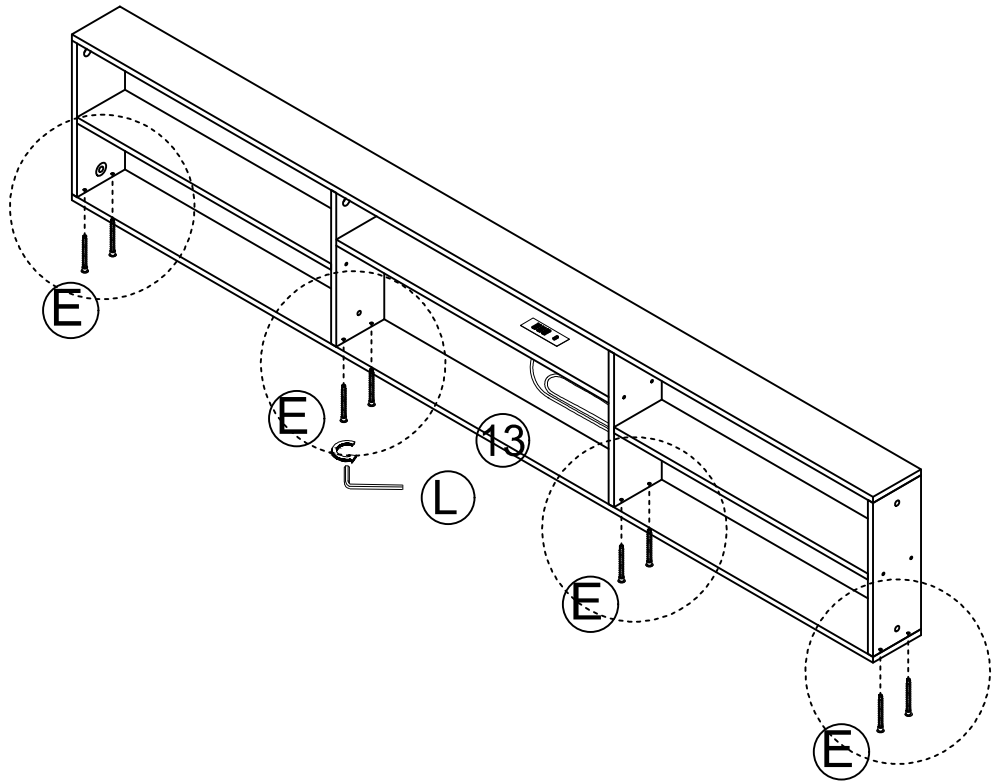

**8** E\*28  
M5×40

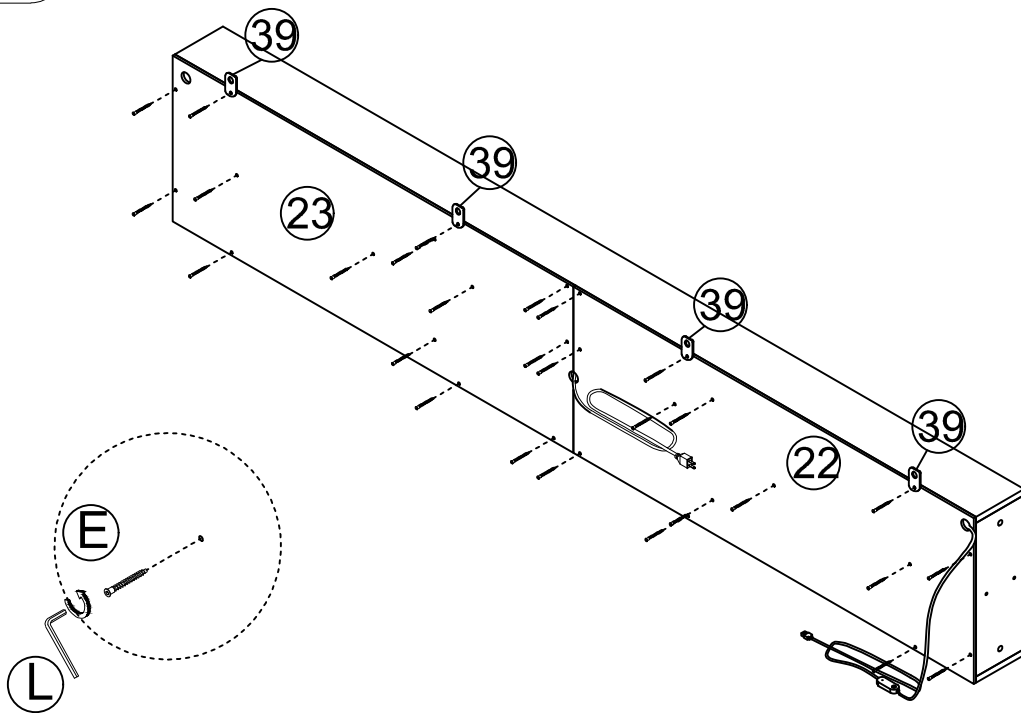

**9** A\*4  
M8×10

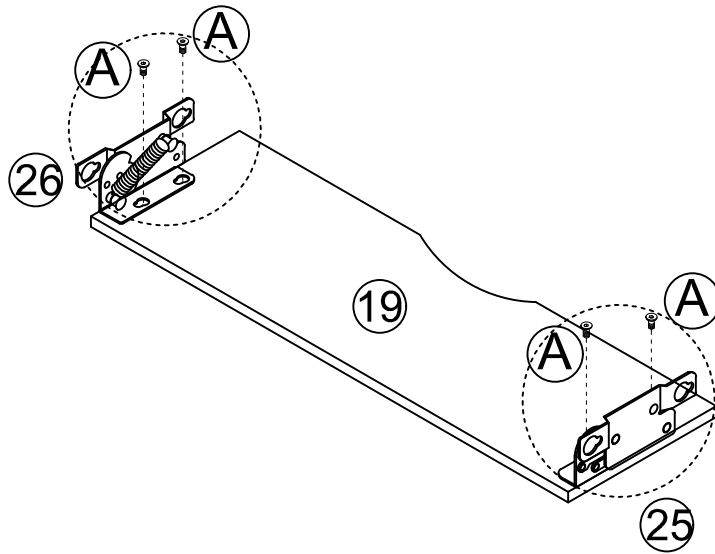
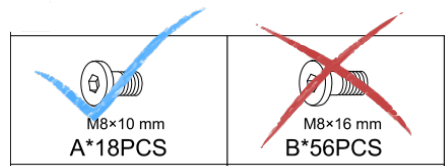

**10** A\*4  
M8×10

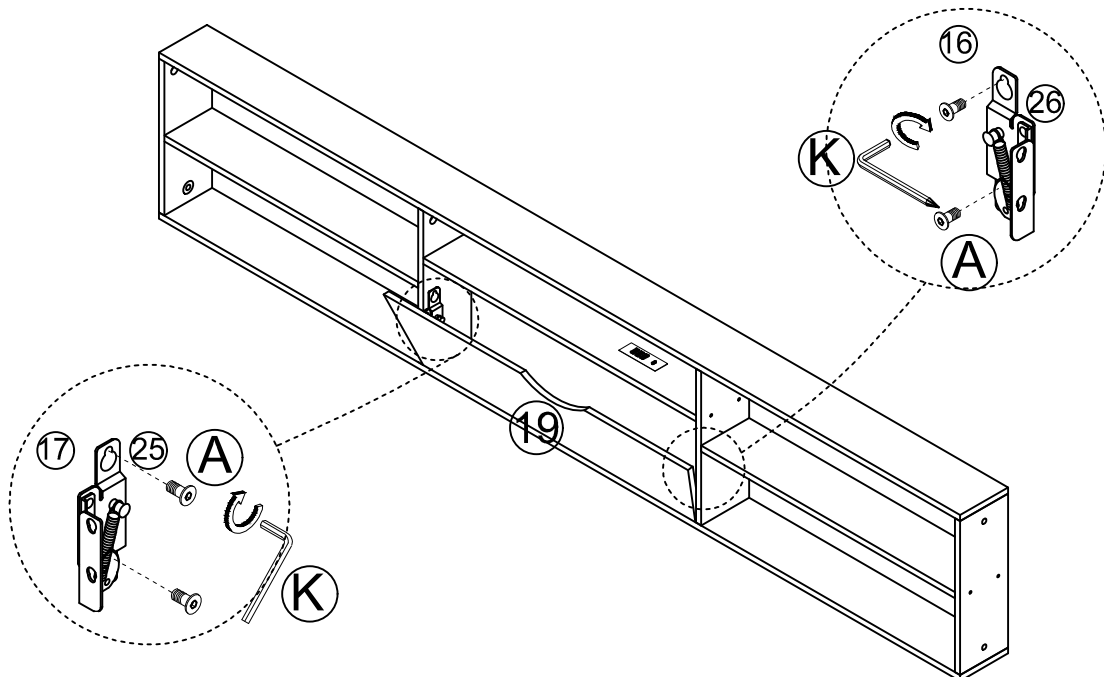
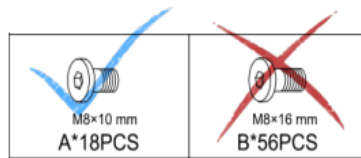

# 11

C\*8 D\*8  
M8×40 Ø8×22mm

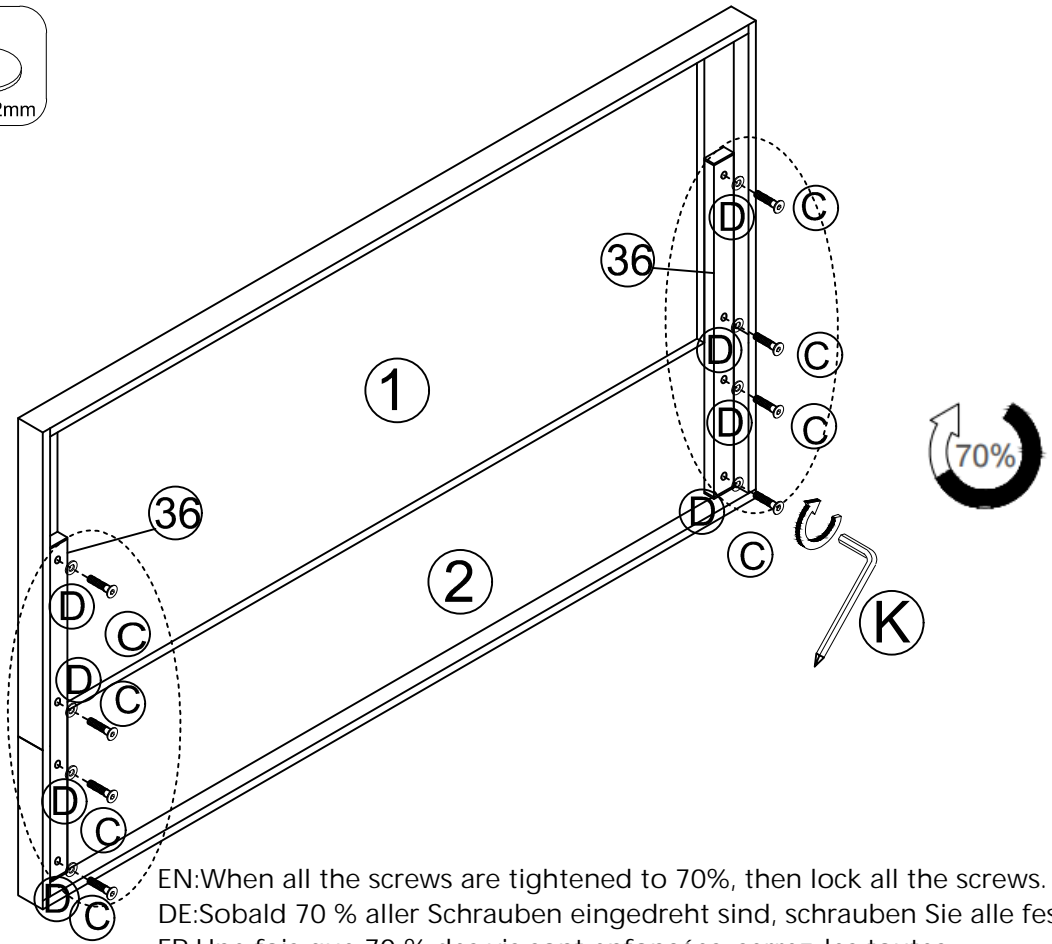

EN: When all the screws are tightened to 70%, then lock all the screws.  
DE: Sobald 70 % aller Schrauben eingedreht sind, schrauben Sie alle fest.  
FR: Une fois que 70 % des vis sont enfoncées, serrez-les toutes.

# 12

B\*8 C\*8  
M8×16 M8×40

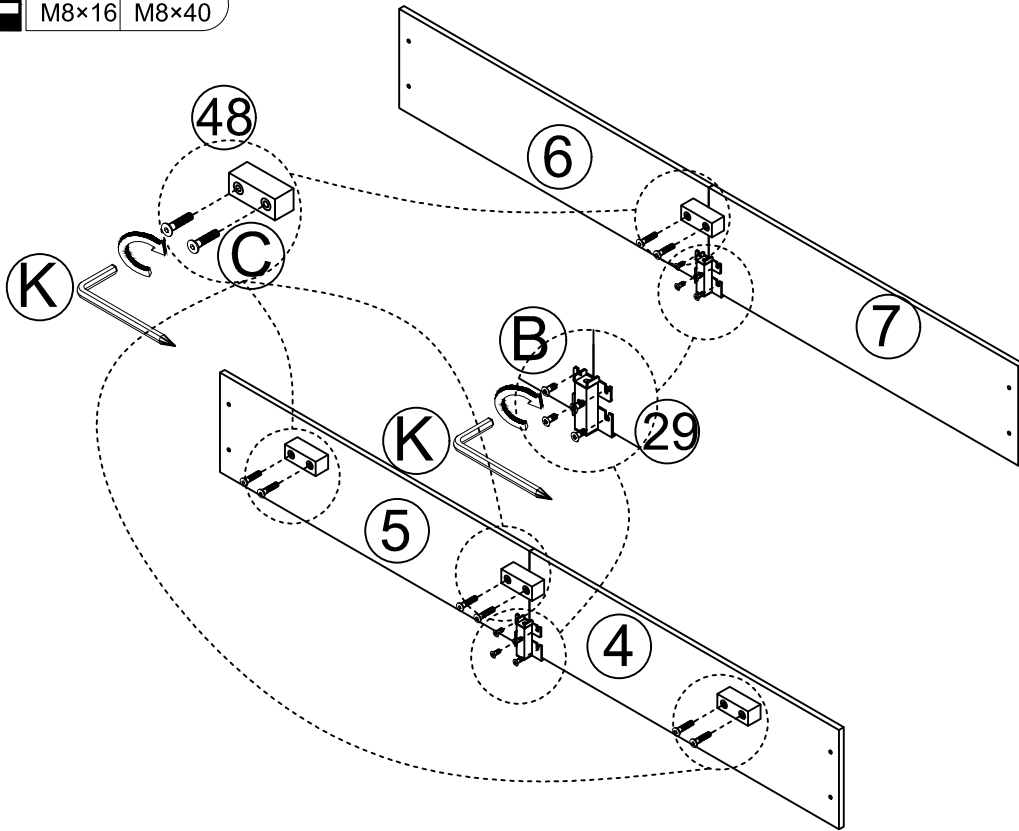

# 13L

B\*12

C\*4



M8x16

M8x40

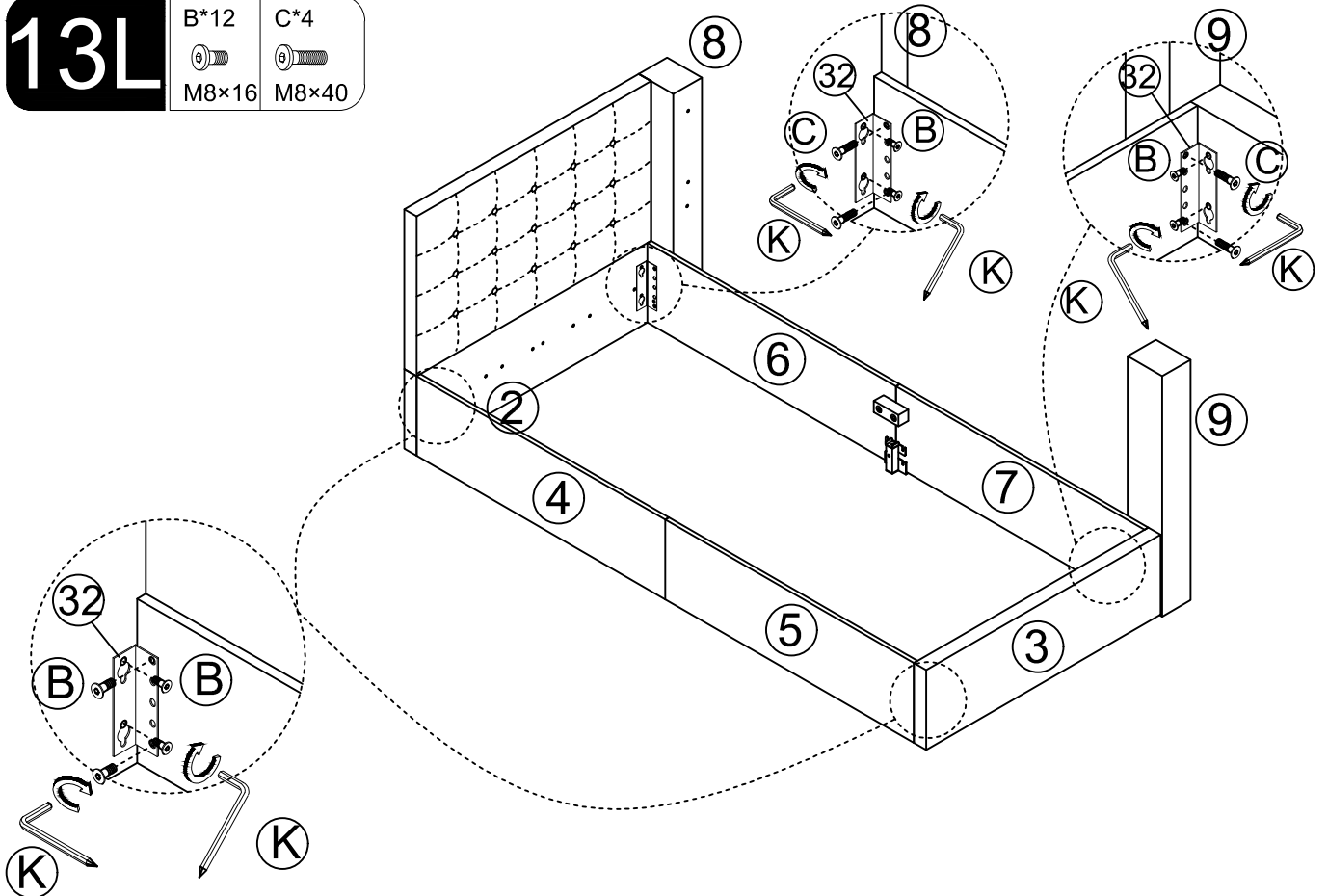

# 13R

B\*12

C\*4



M8x16

M8x40

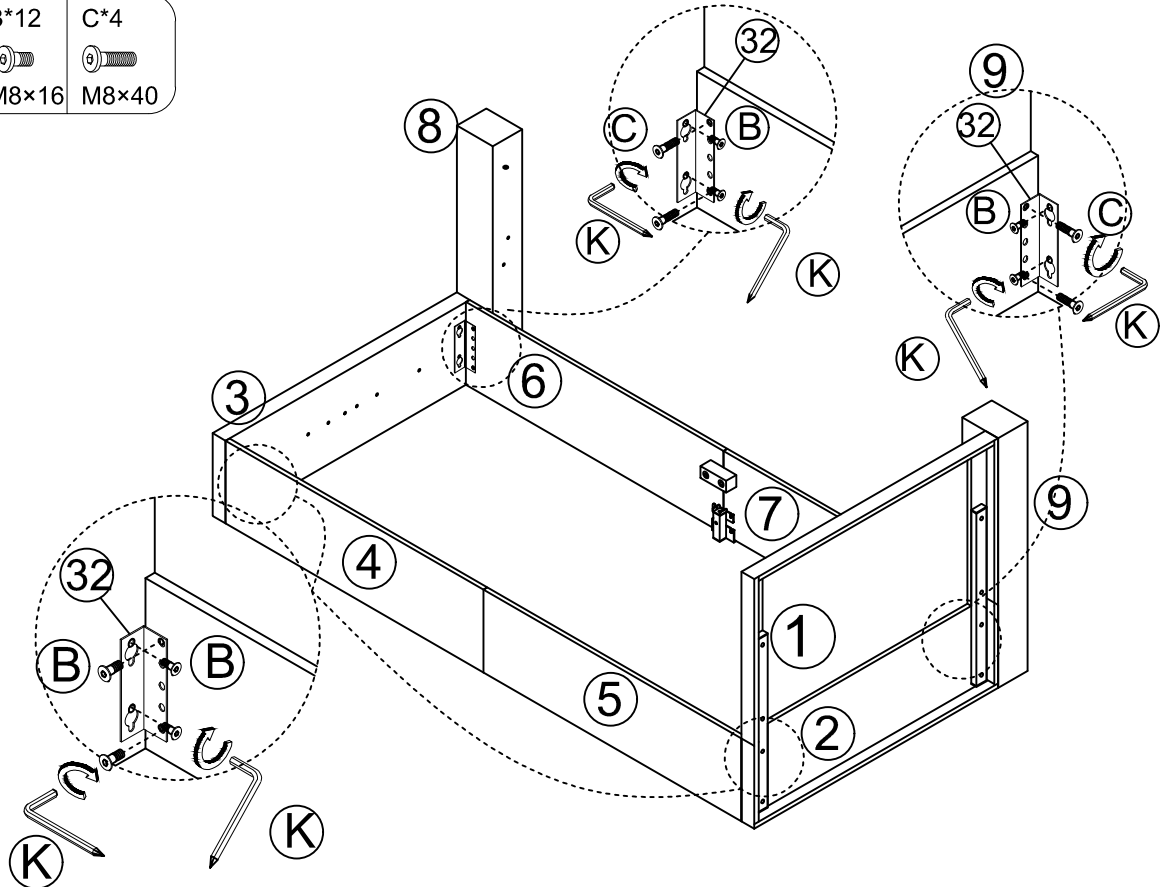

# 14

C\*2



M8x40

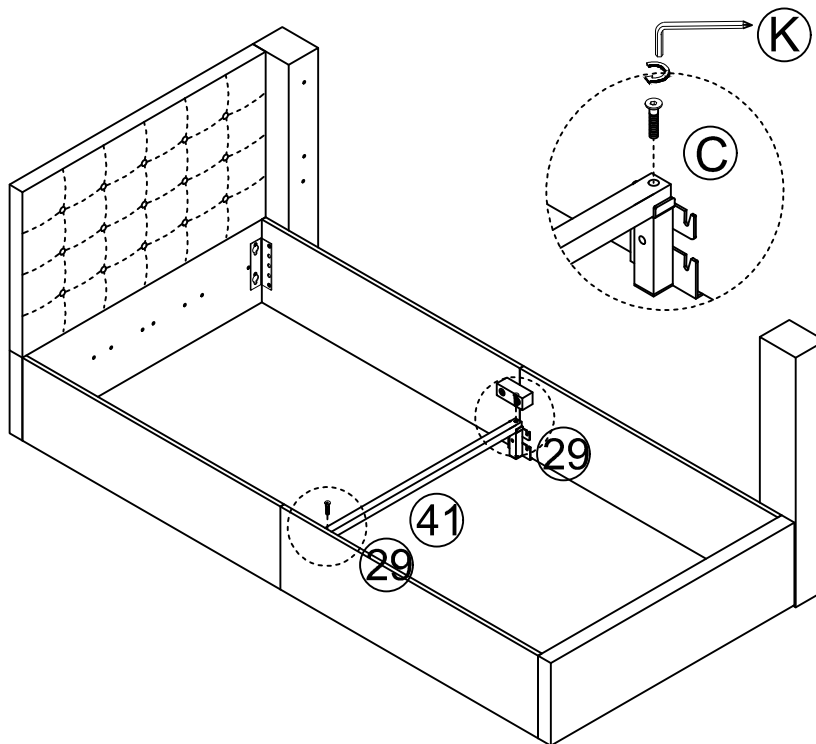

# 15L

B\*2



M8x16

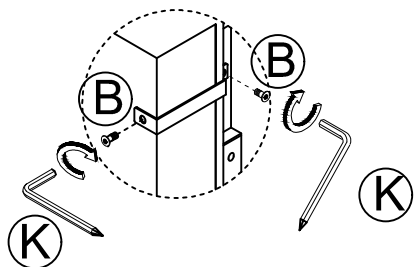
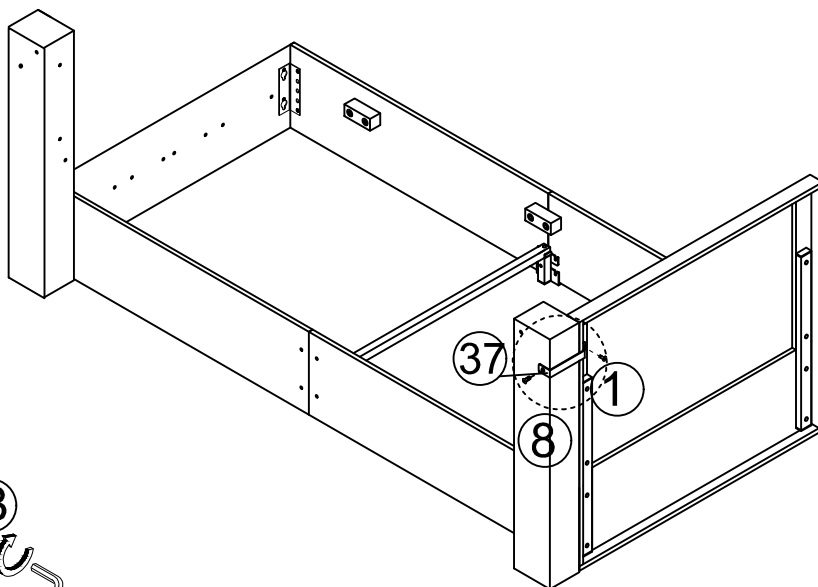

**15R** B\*2  
M8x16

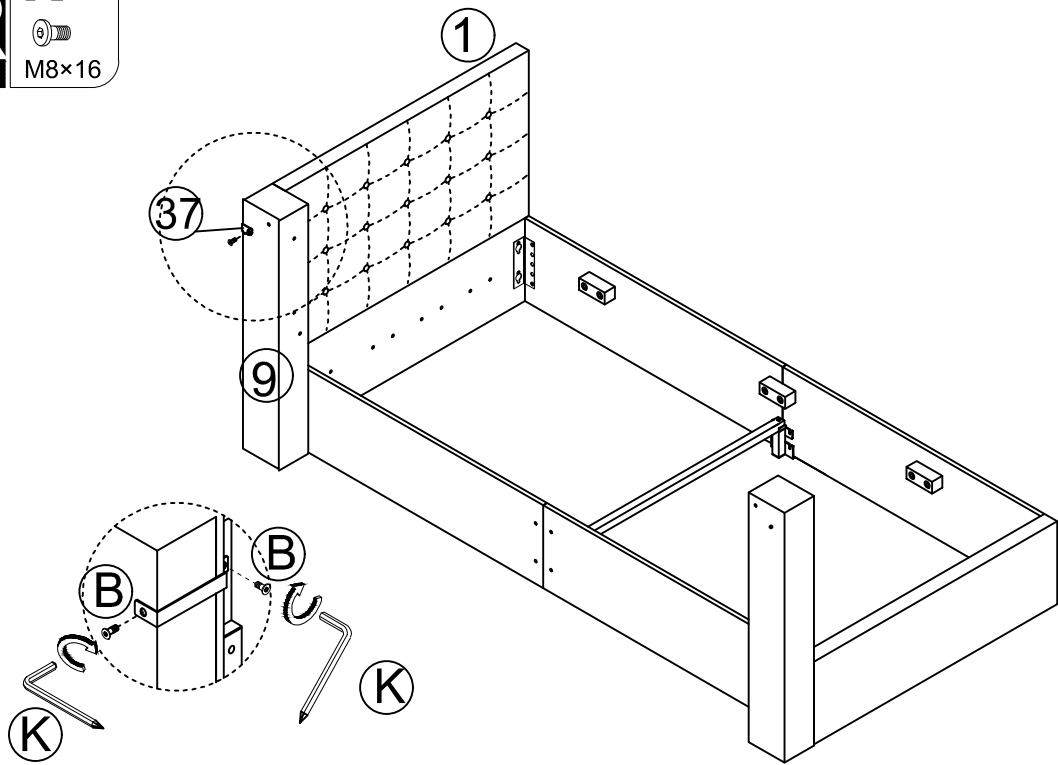

**16** M\*4  
M8x32

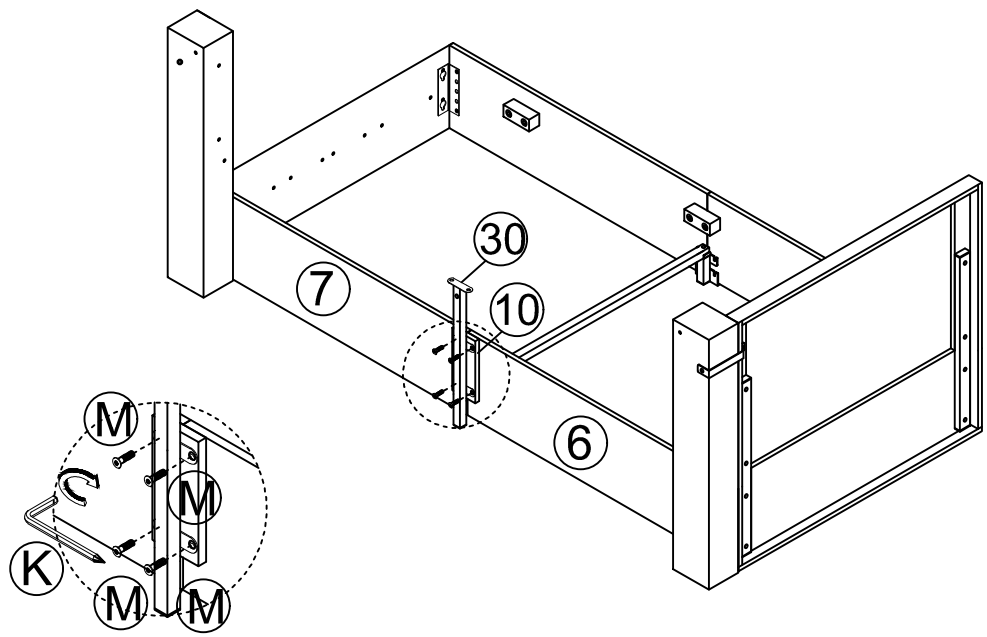

# 17

B\*6

C\*1



M8×16

M8×40

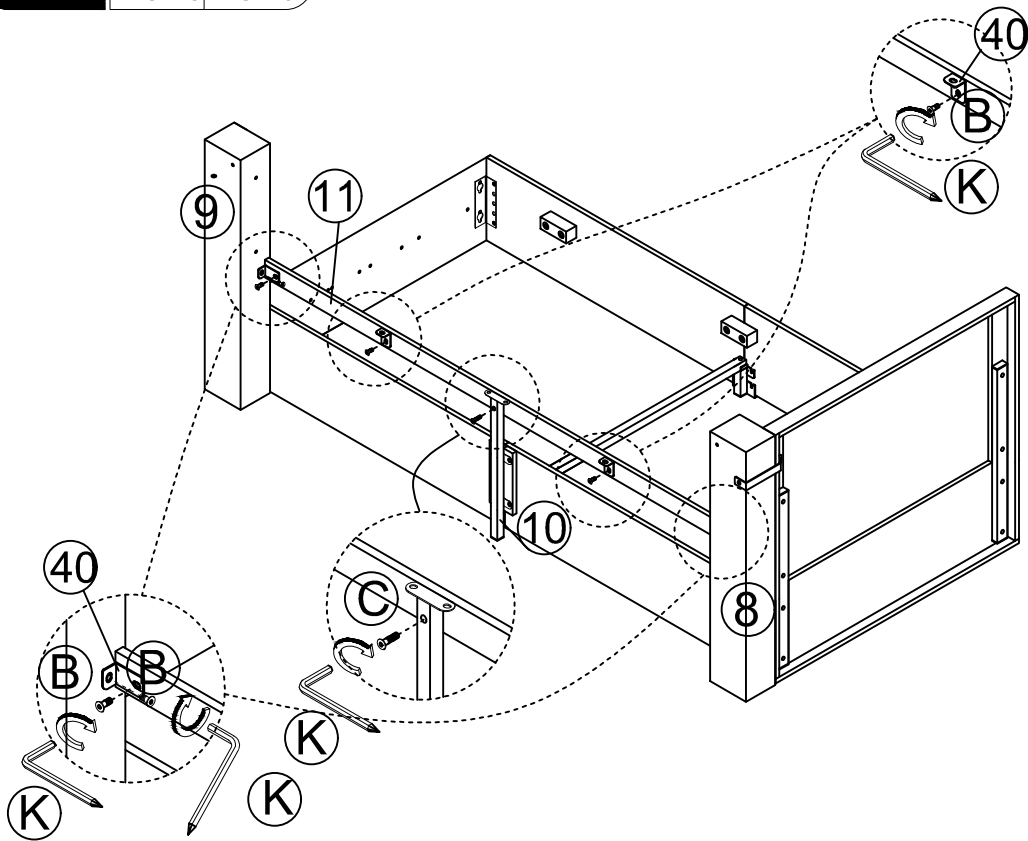

# 18

C\*4

D\*4



M8×40

Ø8×22mm

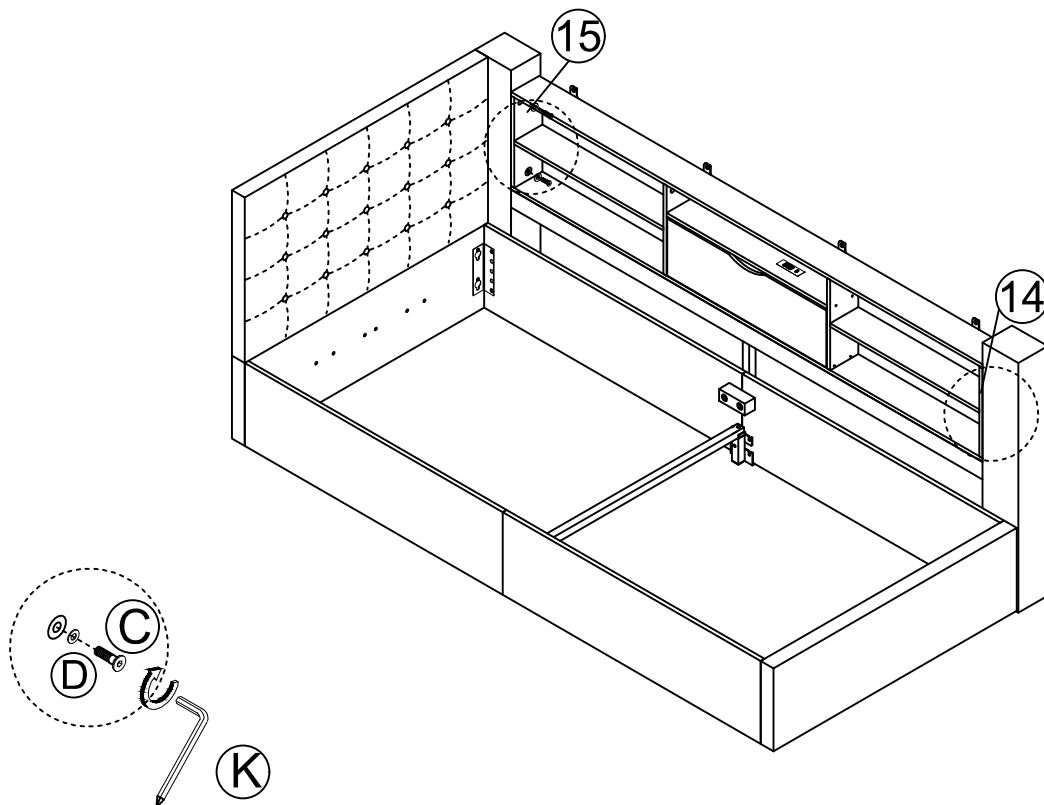

# 19

A\*4



M8×10



M8×10 mm  
A\*18PCS



~~M8×16 mm~~  
B\*56PCS

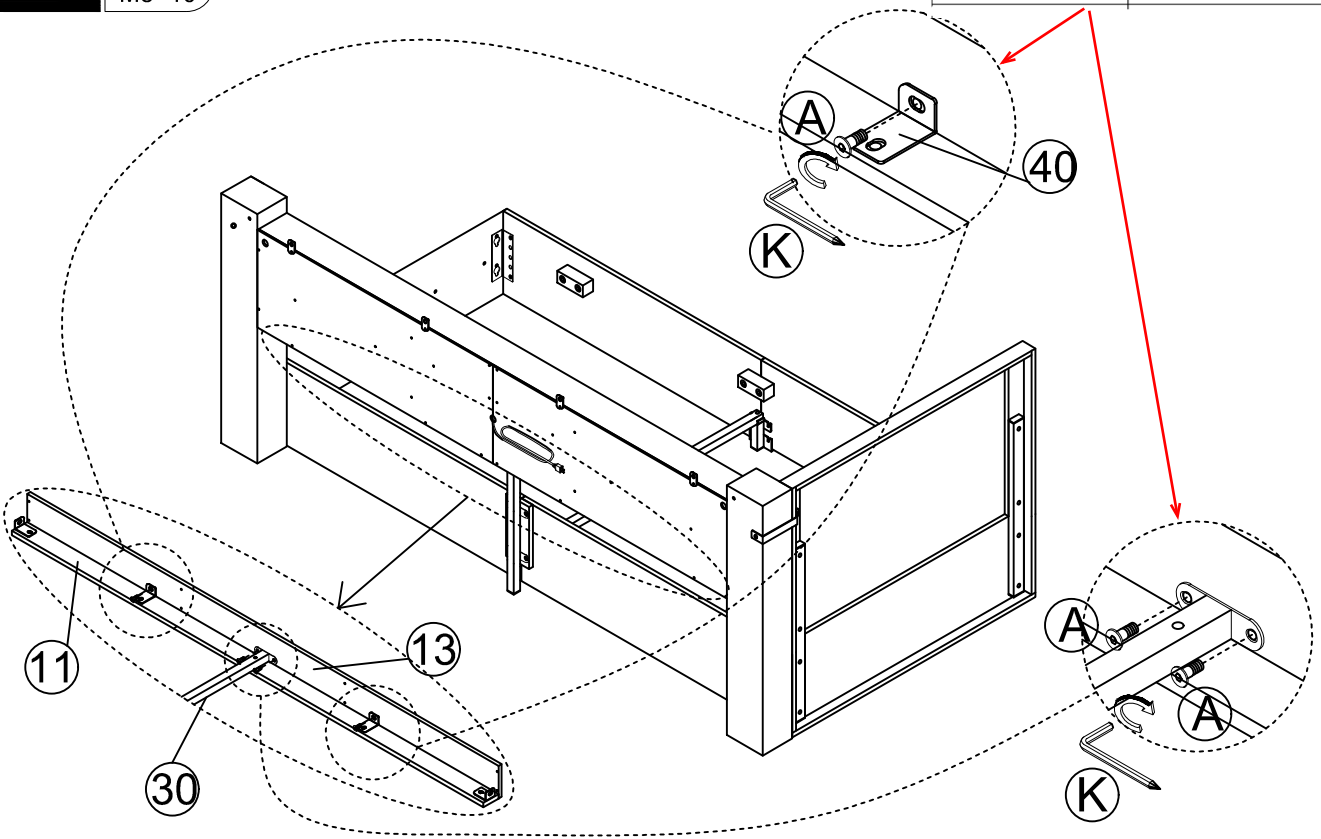

# 20

A\*6



M8×10

B\*2



M8×16

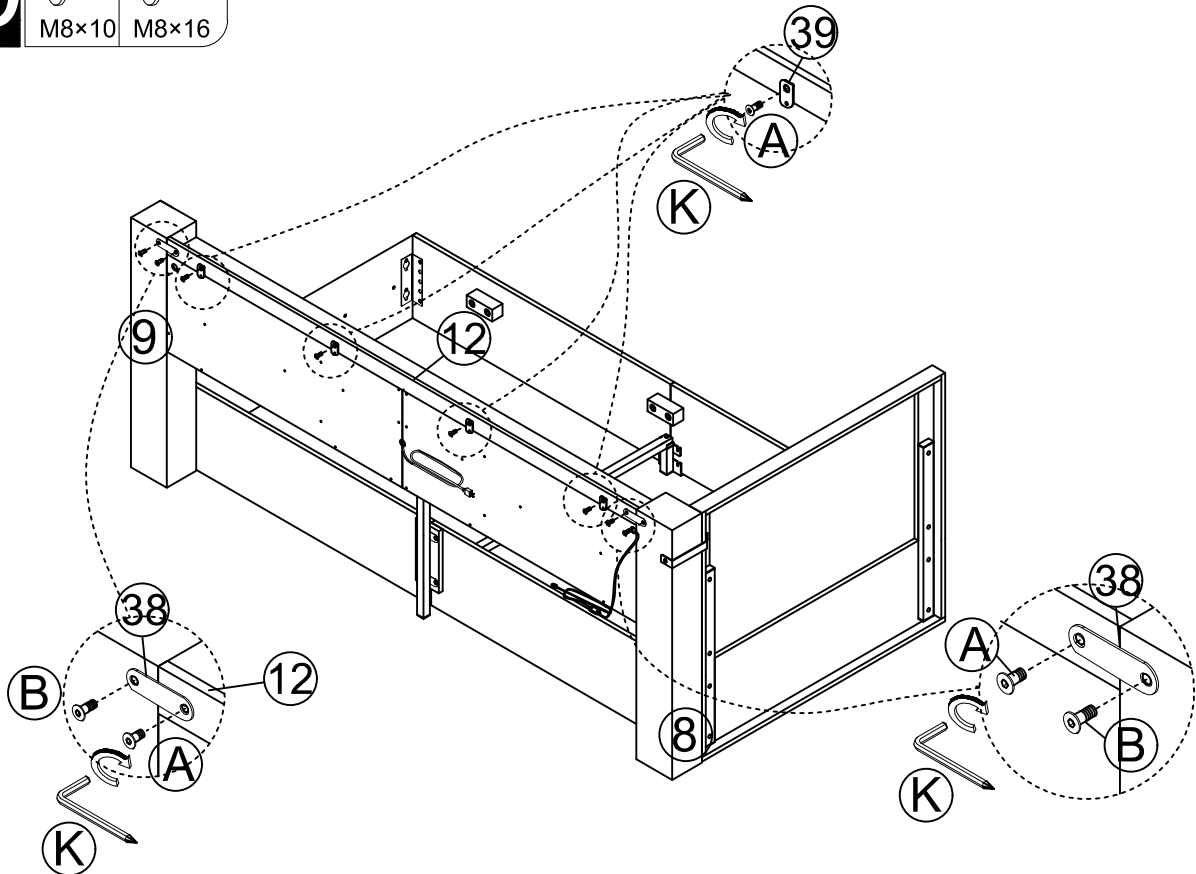

# 21

B\*8



M8×16

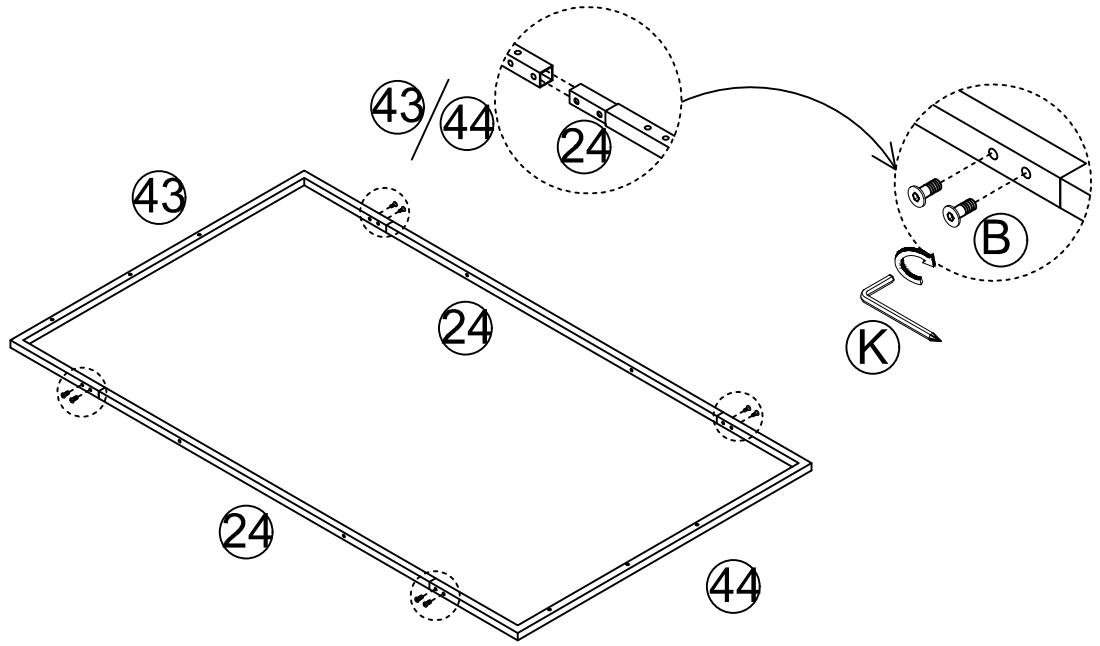

# 22

C\*2



M8×40

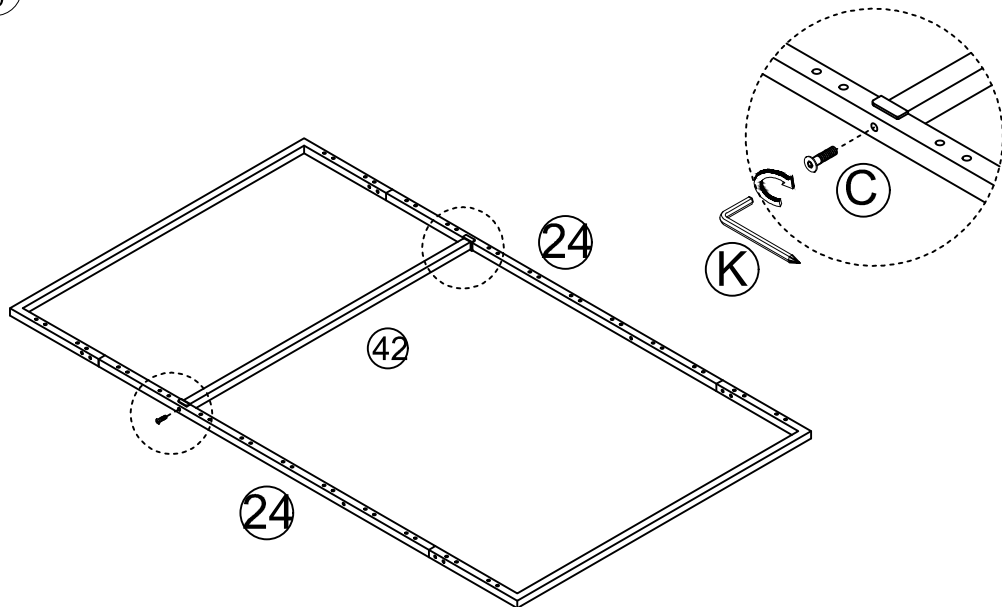

# 23L

B\*8



M8x16

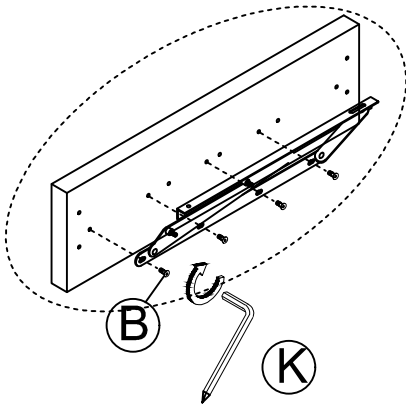
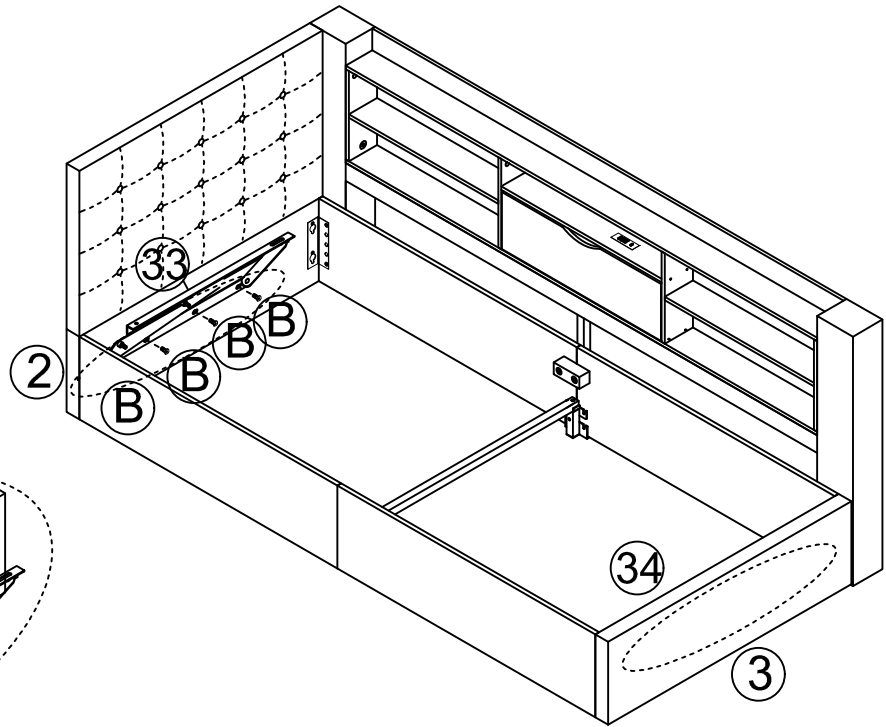

# 23R

B\*8



M8x16

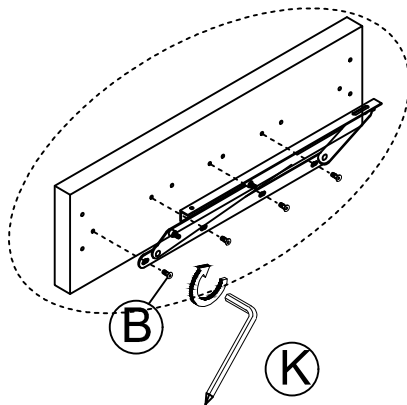
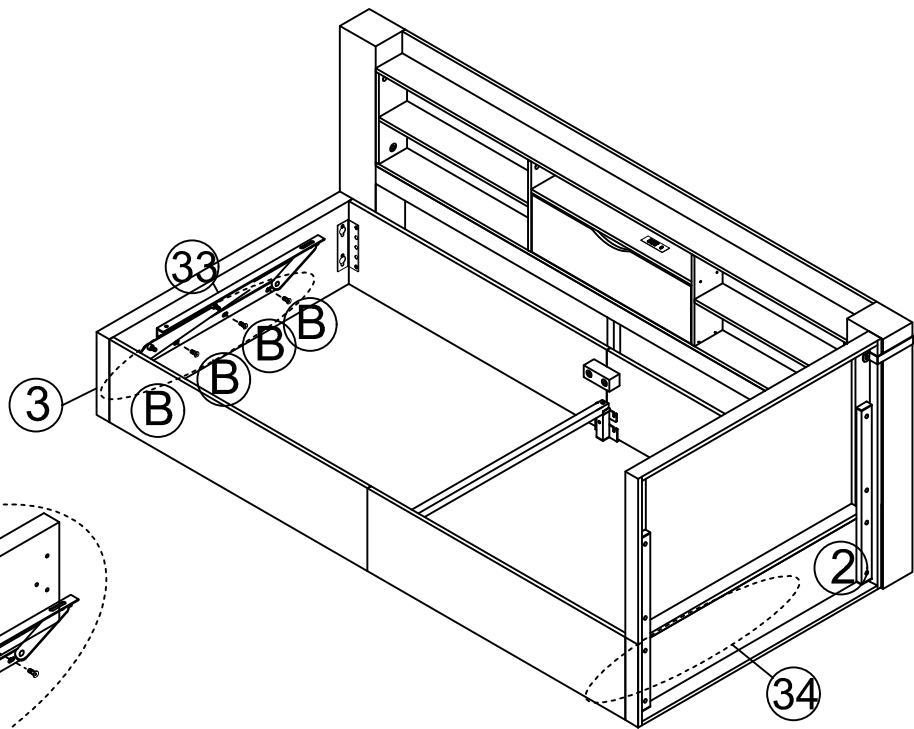

24

I\*4



M8

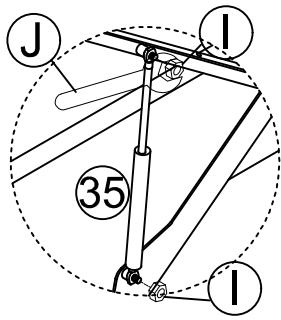
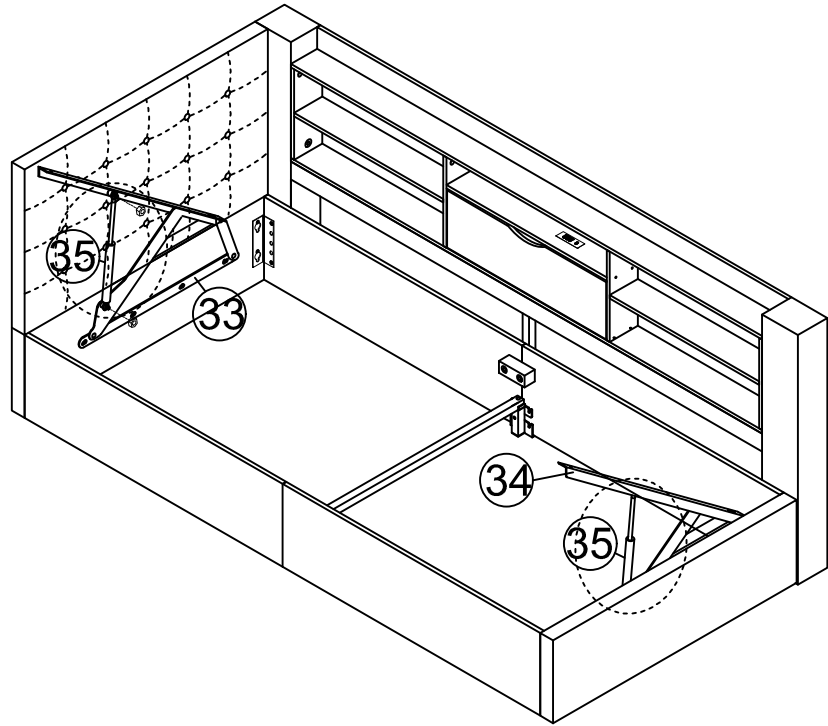

25

B\*6



M8x16

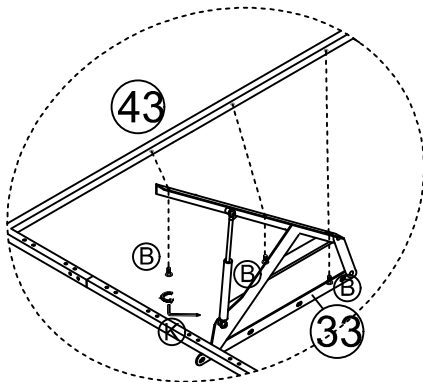
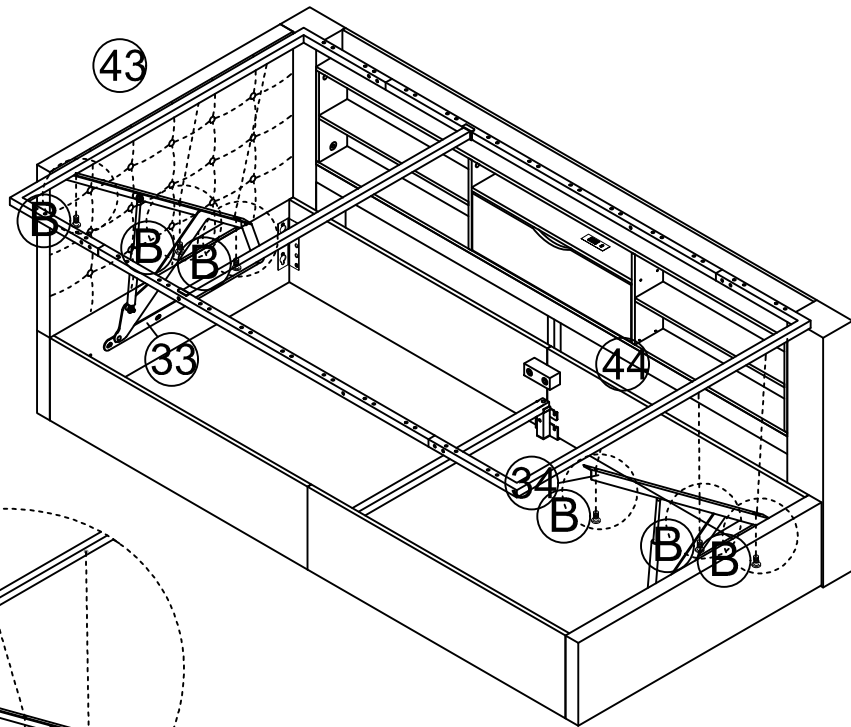

# 26

B\*4



M8×16

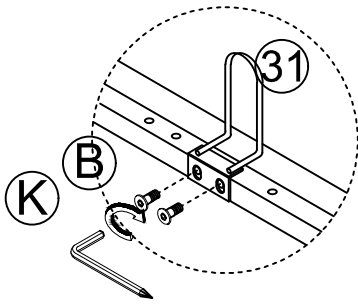
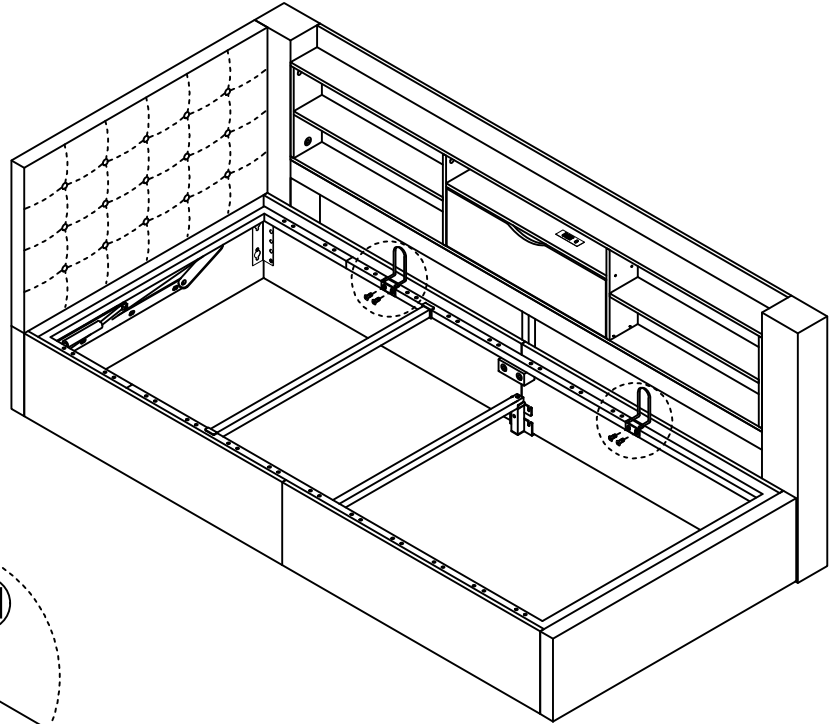

# 27

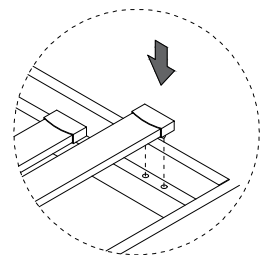
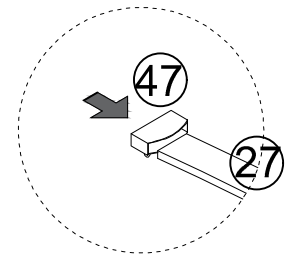
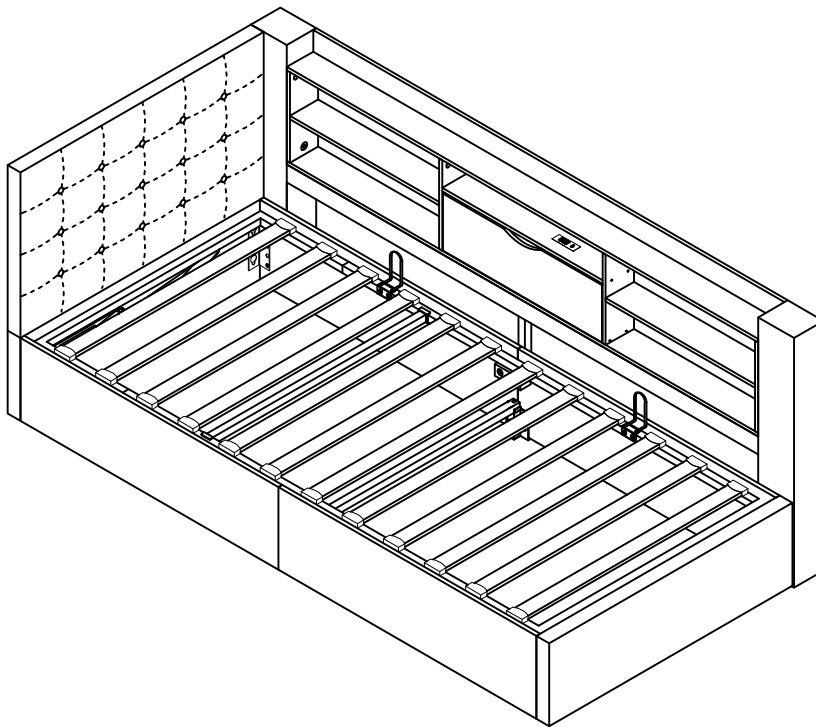

28

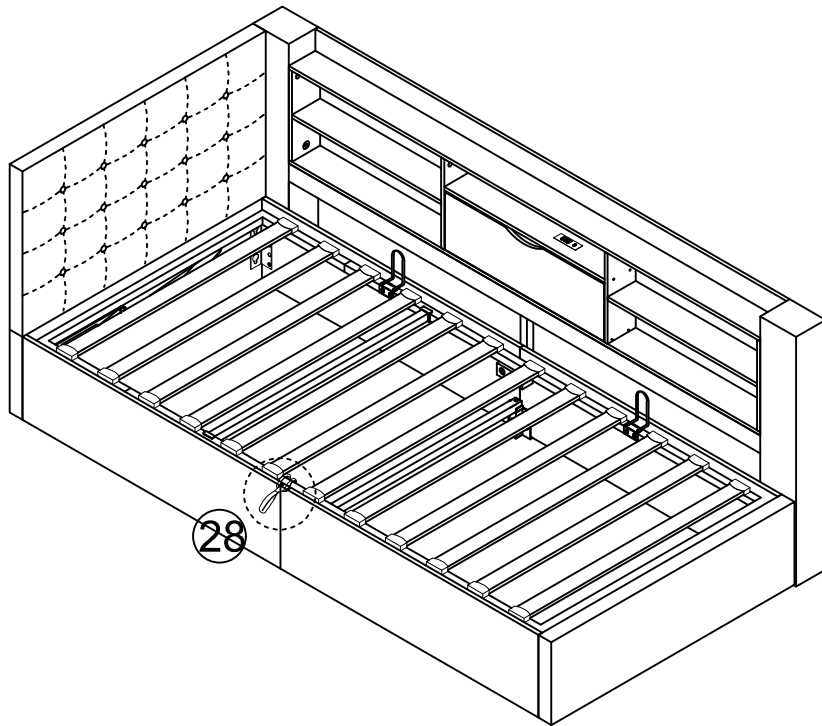

**GB-** NOTE: The battery in the remote control requires you to purchase and install it yourself.  
Model: CR2025

**DE-** HINWEIS: Die Batterie in der Fernbedienung müssen Sie selbst kaufen und installieren.  
Modell: CR2025

**FR-** REMARQUE: la pile de la télécommande doit être achetée et installée par vos soins.  
Modèle: CR2025

**IT-** NOTA: la batteria del telecomando deve essere acquistata e installata autonomamente.  
Modello: CR2025

**ES-** NOTA: La pila del mando a distancia debe comprarla e instalarla usted mismo.  
Modelo: CR2025

①



②



③



④



⑤



⑥



⑦



⑧



Optional: Cover screw holes with included decorative tape.

Optional: Schraublöcher mit beiliegender Dekofolie abdecken.

Optionnel : Masquez les trous de vis avec le ruban décoratif inclus.

Opzionale: Coprire i fori delle viti con il nastro decorativo incluso.

Opcional: Cubra los agujeros de tornillos con la cinta decorativa incluida.

①



②



③



④

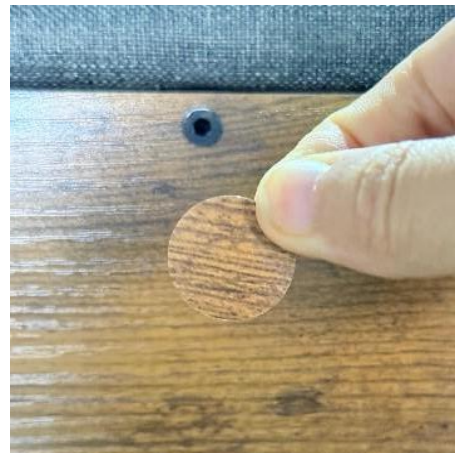

⑤



⑥



# Led Bluetooth MiniController Manual

Please download "LotusLamp X" in the app store or scan the QR code below to download



1 .Download the "LotusLamp X" app with your phone by scanning the QR code or searching for the Lotus Lamp app in the iPhone App Store or Google Play Store.

2. After the APP are downloaded successfully, you need to turn on Bluetooth function on your phone firstly, then plug in the strip light, then open the APP, your APP will pair with the strip light automatically and you can control it.

## Unable to Connect Troubleshooting

(1) Check if the power supply of the light strip is normal.

(2) Check if the Bluetooth is turned on.

(3) Check if there are other mobile phones connected. Bluetooth 4.0 only supports one-to-many connections, it does not support many-to-many.

(4) Check APP Bluetooth settings if the phone is connected to the device. If connected, exit the APP and reopen, the APP will go to connect automatically.

(5) Normal operations and cannot connect, please exit the APP and reopen.

(6) Exit APP, restart mobile phone, power on the strip light. Reopen the APP, then they will connect automatically.



**KEEP** new and used batteries **OUT OF REACH** of **CHILDREN**.  
**Seek immediate medical attention** if a battery is suspected to be swallowed or inserted inside any part of the body.  
If the battery compartment does not close securely, stop using the product and keep it away from children.



If a battery has been ingested, or there is a possibility one might have been ingested, please seek medical attention and inform the medical authorities that you suspect battery ingestion.

It's not always clear when a child has swallowed a button battery, as there are no specific symptoms. However, they might:

- cough, gag, or drool;
- seem to have a stomach bug or virus;
- vomit;
- complain of pain in their stomach, chest, or throat;
- appear tired or sluggish; and
- lose their appetite.

Since the signs aren't obvious, it's important to keep a close eye on loose, used, or spare button batteries in your home, as well as the products that contain them.



# Certificate Of Compliance

**Certificate No.** : BZT252355000415EC  
**Applicant** : Xiamen Zhenlexin Electronic Technology Co., Ltd  
**Address** : 3rd Floor, No. 96, Huli Yuan, Xinmei Sub-district, Tong'an District, Xiamen  
 City  
**Manufacturer** : Xiamen Zhenlexin Electronic Technology Co., Ltd  
**Address** : 3rd Floor, No. 96, Huli Yuan, Xinmei Sub-district, Tong'an District, Xiamen  
 City  
**Product Name** : Light strip  
**Main Model** : ZLX5050RGB-30D  
**Series Models** : ZLX5050RGB-60D (All models share same electric circuits except outer shape and model name.)

Essential requirement		Applied Specifications/Standards	Documentary Evidence	Result
Art.3.1(a)	Health	BS EN 62479:2010	BZT252355000415ER03	Pass
Art.3.1(a)	Safety	BS EN IEC 60598-1:2021+A11:2022 BS EN 60598-2-21:2015	BZT252355000415SR	Pass
Art.3.1(b)	EMC	ETSI EN 301 489-1 V2.2.3 (2019-11) ETSI EN 301 489-3 V2.3.2 (2023-01) BS EN IEC 55015:2019/A11:2020 BS EN IEC 61547:2023 BS EN IEC 61000-3-2:2019+A1:2021+A2:2024 BS EN 61000-3-3: 2013+A1:2019+A2:2021	BZT252355000415ER02	Pass
Art.3.2	Radio	ETSI EN 300 440 V2.2.1 (2018-07)	BZT252355000415ER01	Pass

Technical documentation of the company and the product above have been observed and audit has been completed successfully by us with UK Radio Equipment Regulations (SI 2017 No.1206).

The UKCA mark shown below can only be used under the responsibility of the manufacturer with the completion of UK Declaration of Conformity and other necessary technical documentation for all the relevant regulation(s). The certificate applies to the tested sample above mentioned only and shall not imply an assessment of the whole production.

Remark: This report supersedes BZT252355000415EC which is withdrawn.



Scan QR code  
verification of authenticity



Alex Wu

Alex Wu  
Technical director  
Date: Oct.23, 2025



**Lab Name** : BZT Testing (Dongguan) Co.,Ltd.  
**Lab** : 1F, Bangying Building, Fuma, Chigang Community, Humen Town, Dongguan City,  
**Address** : Guangdong Province, China  
**BZT http** : www.bzt-test.com  
**Telephone** : +86-0769-81516886  
 Confirm the authenticity of Test reports Email: bzt@bzt-test.com



# Certificate Of Compliance

**Certificate No.** : BZT252355000415SC-R1  
**Applicant** : Xiamen Zhenlexin Electronic Technology Co., Ltd  
**Address** : 3rd Floor, No. 96, Huli Yuan, Xinmei Sub-district, Tong'an District, Xiamen City  
**Manufacturer** : Xiamen Zhenlexin Electronic Technology Co., Ltd  
**Address** : 3rd Floor, No. 96, Huli Yuan, Xinmei Sub-district, Tong'an District, Xiamen City  
**Product Name** : Light strip  
**Main Model** : ZLX5050RGB-30D  
**Series Models** : ZLX5050RGB-60D (All models share same electric circuits except outer shape and model name.)  
**Trade mark** : /  
**Test Standard** : BS EN IEC 60598-1:2021+A11:2022  
: BS EN 60598-2-21:2015  
**Report No.** : BZT252355000415SR-R1

Technical documentation of the company and the product above have been observed and audit has been completed successfully by us. The Electrical Equipment (Safety) Regulations 2016 have been taken as references for these processes.

The UKCA mark shown below can only be used under the responsibility of the manufacturer with the completion of UK Declaration of Conformity and other necessary technical documentation for all the relevant regulation(s). The certificate applies to the tested sample above mentioned only and shall not imply an assessment of the whole production. It is only valid in connection with the test report number. BZT252355000415SR-R1



Scan QR code  
verification of authenticity



Alex



Alex Wu  
Technical Director  
Date: Oct. 23, 2025

**Lab Name** : BZT Testing (Dongguan) Co., Ltd.  
**Lab Address** : 1F, Bangying Building, Fuma, Chigang Community, Humen Town Dongguan, GUA, 523900, China  
**Website** : [www.bzt-test.com](http://www.bzt-test.com)      **Telephone** : +86-0769-81516886  
Confirm the authenticity of Test reports Email: [bzt@bzt-test.com](mailto:bzt@bzt-test.com)



# Certificate Of Compliance

**Certificate No.** : BZT252355000417CC-R1  
**Applicant** : Xiamen Zhenlexin Electronic Technology Co., Ltd  
**Address** : 3rd Floor, No. 96, Huli Yuan, Xinmei Sub-district, Tong'an District, Xiamen City  
**Manufacturer** : Xiamen Zhenlexin Electronic Technology Co., Ltd  
**Address** : 3rd Floor, No. 96, Huli Yuan, Xinmei Sub-district, Tong'an District, Xiamen City  
**Sample Name** : Light strip  
**Main Model** : ZLX5050RGB-30D  
**Additional Model** : ZLX5050RGB-60D  
BS EN 62321-1:2013  
BS EN 62321-2:2021  
BS EN 62321-3-1:2013  
BS EN 62321-4:2013/AMD1:2017  
**Test Standard** : BS EN 62321-5:2013  
BS EN 62321-6:2015  
BS EN 62321-7-1:2015  
BS EN 62321-7-2:2017  
BS EN 62321-8:2017  
**As shown in the Test Report No.** : BZT252355000417CR-R1

The EUT described above has been consolidated by us and found in compliance with the council of UK RoHS Restriction of Use of Certain Hazardous Substances in Electrical and Electronic Equipment Regulations SI 2012/3032. The certificate applies to the tested sample above mentioned only and shall not imply an assessment of the whole production. It is only valid in connection with the test report Number BZT252355000417CR-R1.



Scan QR code  
verification of authenticity

**UK  
CA** **RoHS**

Mark Wen



Mark Wen  
Technical director  
Date: Oct.28,2025

**Lab Name** : BZT Testing (Dongguan) Co., Ltd.  
**Lab** : 1F, Banging building, Fuma, Chigang community, Humen Town, Dongguan City,  
**Address** : Guangdong Province, China  
**BZT http** : [www.bzt-test.com](http://www.bzt-test.com) **Telephone** : +86-0769-81516886  
Confirm the authenticity of Test reports Email: [bzt@bzt-test.com](mailto:bzt@bzt-test.com)



# CERTIFICATE OF CONFORMITY

## Electromagnetic Compatibility Regulations 2016 (SI 2016 No. 1091)

This Certificate of Conformity is hereby issued to the product designated below:

**Certificate No.**..... : 25EP06144E02  
**Report No.**..... : EP2506144E02  
**Date Issue.** ..... : 2025-07-07  
**Applicant's name** ..... : Zhangzhou Jinhe Electronic Technology Co., Ltd  
**Address** ..... : 2nd Floor, Building 2, No.15 Jinxia Road, Wenpu Industrial Park,  
JiaomeiTown, Zhangzhou City, Fujian Province,China  
**Manufacturer's name** ..... : Zhangzhou Jinhe Electronic Technology Co., Ltd  
**Address** ..... : 2nd Floor, Building 2, No.15 Jinxia Road, Wenpu Industrial Park,  
JiaomeiTown, Zhangzhou City, Fujian Province,China  
**Product Description**..... : Power Supply  
**Model(s)/Type References** : JH-14Y  
**Parameters**..... : See appendix for details  
**Standard(s)** ..... : BS EN 55032:2015+A11:2020+A1:2020  
BS EN 55035:2017+A11:2020  
BS EN IEC 61000-3-2:2019+A1:2021+A2:2024  
BS EN 61000-3-3:2013+A1:2019+A2:2021

On the basis of the referenced test report(s), sample(s) tested of the above product have been found to comply with the standards harmonized with the directives listed on this verification at the time the tests were carried out. Other standards and Directives may be relevant to the product. This verification is part of the full test report(s) and should be read in conjunction with it(them).

Once compliance with all product relevant UKCA mark directives are verified, including any relevant e.g. risk assessment and production control, the manufacturer may indicate compliance by signing a Declaration of Conformity themselves and applying the mark to products identical to the tested sample(s).

Approved By

Eric Liu  
Director of Engineering department





# CERTIFICATE OF CONFORMITY

## Electrical Equipment (Safety) Regulation 2016

This Certificate of Conformity is hereby issued to the product designated below:

**Certificate No.** ..... : 25SP06144L02  
**Report No.** ..... : SP2506144L02  
**Date Issue.** ..... : 2025-07-04  
**Applicant's name** ..... : Zhangzhou Jinhe Electronic Technology Co., Ltd  
**Address** ..... : 2nd Floor, Building 2, No.15 Jinxia Road, Wenpu Industrial Park,  
JiaomeiTown, Zhangzhou City, Fujian Province,China  
**Manufacturer's name** ..... : Zhangzhou Jinhe Electronic Technology Co., Ltd  
**Address** ..... : 2nd Floor, Building 2, No.15 Jinxia Road, Wenpu Industrial Park,  
JiaomeiTown, Zhangzhou City, Fujian Province,China  
**Product Description** ..... : Power Supply  
**Model(s)/Type References** : JH-14Y  
**Parameters** ..... : See appendix for details  
**Standard(s)** ..... : BS EN IEC 62368-1:2020+A11:2020

On the basis of the referenced test report(s), sample(s) tested of the above product have been found to comply with the standards harmonized with the directives listed on this verification at the time the tests were carried out. Other standards and Directives may be relevant to the product. This verification is part of the full test report(s) and should be read in conjunction with it(them).

Once compliance with all product relevant UKCA mark directives are verified, including any relevant e.g. risk assessment and production control, the manufacturer may indicate compliance by signing a Declaration of Conformity themselves and applying the mark to products identical to the tested sample(s).

Approved By

.....  
Eric Liu  
Director of engineering department



Certificate No. : HUAX260104705KC



# Certificate of Conformity

**Certificate's Holder** : Zhangzhou Jinhe Electronic Technology Co., Ltd  
**Address** : iao Mei Zhen Hong Jian Cun Jiao Song, Taiwan Merchants  
 : Investment Zone, Zhangzhou, Fujian Province 3rd Floor,  
 Building C, No. 59 Road

**Manufacturer** : Zhangzhou Jinhe Electronic Technology Co., Ltd  
**Address** : iao Mei Zhen Hong Jian Cun Jiao Song, Taiwan Merchants  
 : Investment Zone, Zhangzhou, Fujian Province 3rd Floor,  
 Building C, No. 59 Road

**Product Name** : Embedded socket

**Product Model (S)** : JH-15, JH-51, JH-52, JH-53, JH-54, JH-55, JH-56, JH-57,  
 : JH-58, JH-59, JH-60, JH-14Y, JH-14

**Trade Mark** : N/A

**Related Standard(s)** : IEC 62321-3-1:2013, IEC 62321-5:2013,  
 IEC 62321-4:2017, IEC 62321-7-1:2015,  
 IEC 62321-7-2:2017, IEC 62321-6:2015 ,  
 IEC 62321-8:2017

**Report No.** : HUAX260104705KR

The product described above has been consolidated by us and found in compliance with the council RoHS 2.0 Directive (EU) 2015/863 and (EU)2017/2102 amending Annex II to Directive 2011/65/EU It is only valid in connection with the test report



*Kevin Su*  
 Jan. 06, 2022  
 Certification Manager

**Shenzhen Huaxiang Testing Co., Ltd**  
 1st Floor, Building A1, No. 2082 Jincheng Road, Shajing  
 Street, Bao'an District, Shenzhen City, Guangdong Province,  
 China Web.: [Http:// www.hua-x.com](http://www.hua-x.com)  
 E-mail: [huaxiang@hua-x.com](mailto:huaxiang@hua-x.com) Tel.: +86-0755-23010432

