

N625P183801/N625P183804  
N605P439610/N605P439611

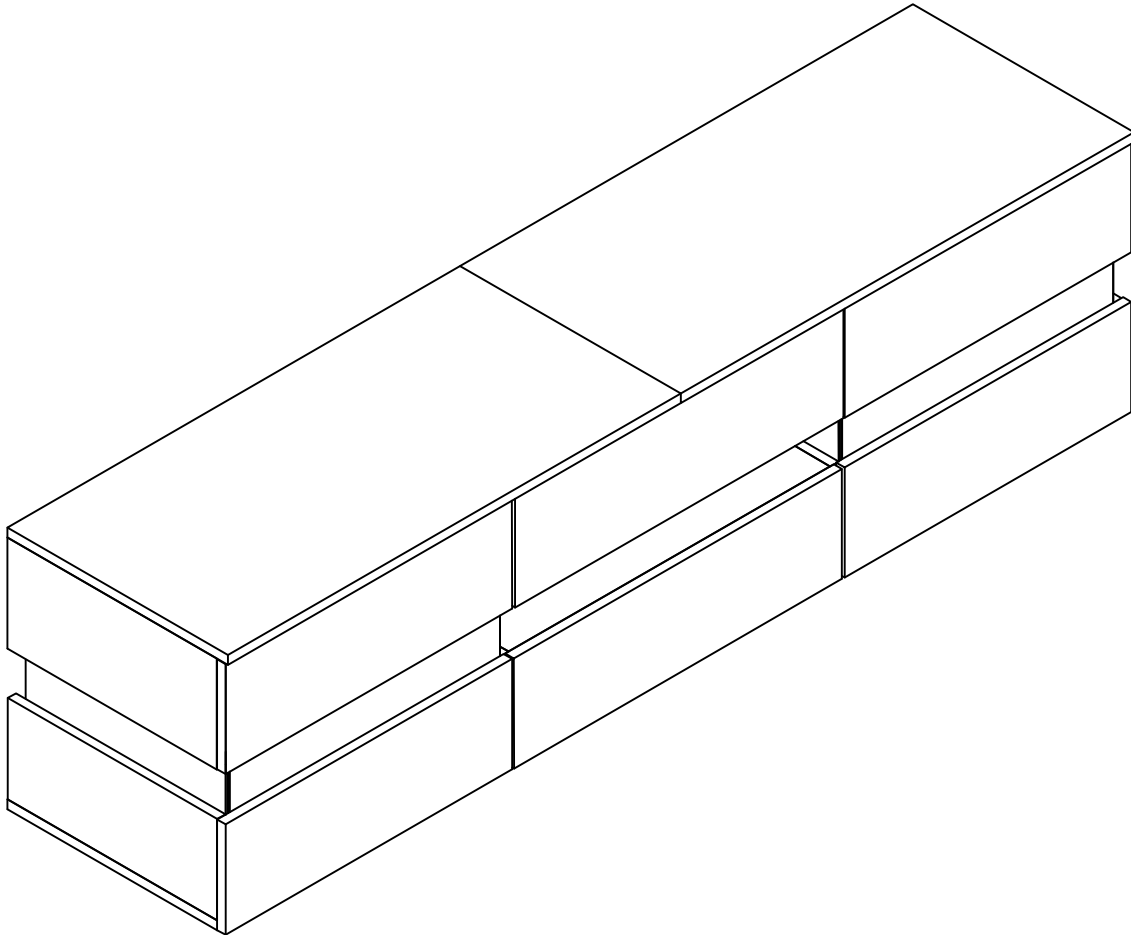

Product manual  
Gebrauchsanweisung  
Manuel du produit  
Manual del producto  
Manuale del prodotto



FR

Cet appareil,  
ses cordons,  
et batterie  
se recyclent

À DÉPOSER  
EN MAGASIN



À DÉPOSER  
EN DÉCHÈTERIE



OU

Points de collecte sur [www.quefairedemesdechets.fr](http://www.quefairedemesdechets.fr)  
Privilégiez la réparation ou le don de votre appareil !

EN:Our product will be delivered to you in 2 packages.  
The delivery times of these 2 packages may differ, please be patient and thank you for your understanding

FR:Notre produit vous sera livré en 2 colis. Les délais de livraison de ces 2 colis peuvent différer, soyez patient et merci de votre compréhension.

DE:Unser Produkt wird Ihnen in 2 Paketen geliefert. Die Lieferzeiten dieser 2 Pakete können abweichen, bitte haben Sie etwas Geduld und vielen Dank für Ihr Verständnis

IT:I nostri prodotti vengono trasportati in due pacchetti. I tempi di consegna dei due pacchetti sono diversi: abbiate pazienza e vi ringrazio per la vostra comprensione.

ES:Nuestro producto se entrega en dos paquetes. El tiempo de entrega de estos dos paquetes es diferente. Por favor, sea paciente. Gracias por su comprensión.

Tool Required Not Provided

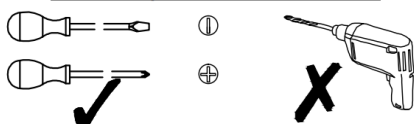

2PERS



45 MIN



[DE]

**Warnung:** Lesen Sie diese Anleitung vor dem Zusammenbau bitte vollständig durch. Überprüfen Sie, ob Sie alle auf den Seiten aufgeführten Komponenten und Werkzeuge haben. Bewahren Sie die Anleitung zum späteren Nachschlagen auf. Teile des Zusammenbaus lassen sich mit 2 Personen leichter durchführen. Suchen Sie bei Bedarf professionelle Hilfe.

**Warnung:** Legen Sie alle Teile auf eine ebene Fläche. Legen Sie eine weiche Decke oder Ähnliches darunter, um sie vor Kratzern oder Flecken zu schützen. Vermeiden Sie es, Komponenten über den Boden zu ziehen oder zu schieben.

**Warnung:** Überprüfen Sie regelmäßig alle Beschläge und Befestigungen, um sicherzustellen, dass sie sicher sind und um Unfälle zu vermeiden. Wenn Teile fehlen, kaputt, beschädigt oder abgenutzt sind, verwenden Sie das Produkt nicht weiter, bis es mit vom Hersteller autorisierten Teilen repariert wurde.

**Warnung:** Lassen Sie Kinder nicht auf die Möbel klettern, da dies zum Umkippen und zu schweren Verletzungen führen kann. Bauen Sie die Möbel außerhalb der Reichweite von Kindern zusammen.

**Warnung:** Stellen Sie die Möbel nicht in die Nähe von Feuerquellen oder heißen Gegenständen, um Brandgefahr zu vermeiden.

**Warnung:** Reinigen Sie die Möbel mit einem feuchten Tuch oder Alkohol. Verwenden Sie keine Reinigungsmittel mit ätzenden Chemikalien.

[EN]

**Warning:** Please read these instructions fully before starting assembly. Check you have all the components and tools listed on pages. Keep the instructions for later reference. Parts of the assembly will be easier with 2 people. Seek professional assistance if necessary.

**Warning:** Please place all parts on a flat surface. Place a soft blanket or similar underneath to protect against scratches or stains. Avoid dragging or sliding components across the floor.

**Warning:** Regularly check all fittings and fastenings to ensure they are secure and to prevent accidents. If any parts are missing, broken, damaged, or worn, discontinue use of the product until repairs have been made using factory authorized parts.

**Warning:** Do not allow children to climb on the furniture as this may result in tipping and serious personal injury. Assemble the furniture away from the reach of children.

**Warning:** Do not place furniture close to fire sources or high-temperature objects to avoid the risk of fire. Do not place furniture in damp environments to prevent material damage.

**Warning:** Clean furniture with a damp cloth or alcohol, avoid using cleaning agents containing corrosive chemicals.

[FR]

**Avertissement :** Veuillez lire attentivement ces instructions avant de commencer l'assemblage. Vérifiez que vous disposez de tous les composants et outils répertoriés sur les pages. Conservez les instructions pour référence ultérieure. Certaines parties de l'assemblage seront plus faciles à 2 personnes. Demandez l'aide d'un professionnel si nécessaire.

**Avertissement :** Veuillez placer toutes les pièces sur une surface plane. Placez une couverture douce ou similaire en dessous pour les protéger des rayures ou des taches. Évitez de faire glisser les composants sur le sol.

**Avertissement :** Vérifiez régulièrement tous les raccords et fixations pour vous assurer qu'ils sont bien fixés et pour éviter les accidents. Si des pièces manquent, sont cassées, endommagées ou usées, cessez d'utiliser le produit jusqu'à ce que des réparations aient été effectuées à l'aide de pièces autorisées par l'usine.

**Avertissement :** Ne laissez pas les enfants grimper sur les meubles car cela pourrait entraîner un basculement et des blessures graves. Assemblez les meubles hors de portée des enfants.

**Avertissement :** Ne placez pas les meubles à proximité de sources de feu ou d'objets à haute température pour éviter tout risque d'incendie.

**Avertissement :** Nettoyez les meubles avec un chiffon humide ou de l'alcool, évitez d'utiliser des produits de nettoyage contenant des produits chimiques corrosifs.

[IT]

**Attenzione:** leggere attentamente queste istruzioni prima di iniziare il montaggio. Verificare di avere tutti i componenti e gli strumenti elencati nelle pagine. Conservare le istruzioni per riferimento futuro. Alcune parti del montaggio saranno più facili con 2 persone. Se necessario, chiedere assistenza professionale.

**Attenzione:** posizionare tutte le parti su una superficie piana. Posizionare una coperta morbida o simile sotto per proteggere da graffi o macchie. Evitare di trascinare o far scivolare i componenti sul pavimento.

**Attenzione:** controllare regolarmente tutti i raccordi e i dispositivi di fissaggio per assicurarsi che siano sicuri e per prevenire incidenti. Se alcune parti sono mancanti, rotte, danneggiate o usurate, interrompere l'uso del prodotto fino a quando non siano state eseguite le riparazioni utilizzando parti autorizzate dalla fabbrica.

**Attenzione:** non consentire ai bambini di arrampicarsi sui mobili poiché ciò potrebbe causare ribaltamenti e gravi lesioni personali. Montare i mobili lontano dalla portata dei bambini.

**Attenzione:** non posizionare i mobili vicino a fonti di fuoco o oggetti ad alta temperatura per evitare il rischio di incendio

**Attenzione:** pulire i mobili con un panno umido o alcol, evitare di utilizzare detergenti contenenti sostanze chimiche corrosive.

[ES]

**Advertencia:** Lea estas instrucciones completamente antes de comenzar el montaje. Compruebe que tiene todos los componentes y herramientas que se enumeran en las páginas. Conserve las instrucciones para consultarlas más adelante. El montaje de algunas partes será más sencillo con 2 personas. Busque ayuda profesional si es necesario.

**Advertencia:** Coloque todas las piezas sobre una superficie plana. Coloque una manta suave o algo similar debajo para protegerlas de rayones o manchas. Evite arrastrar o deslizar los componentes por el piso.







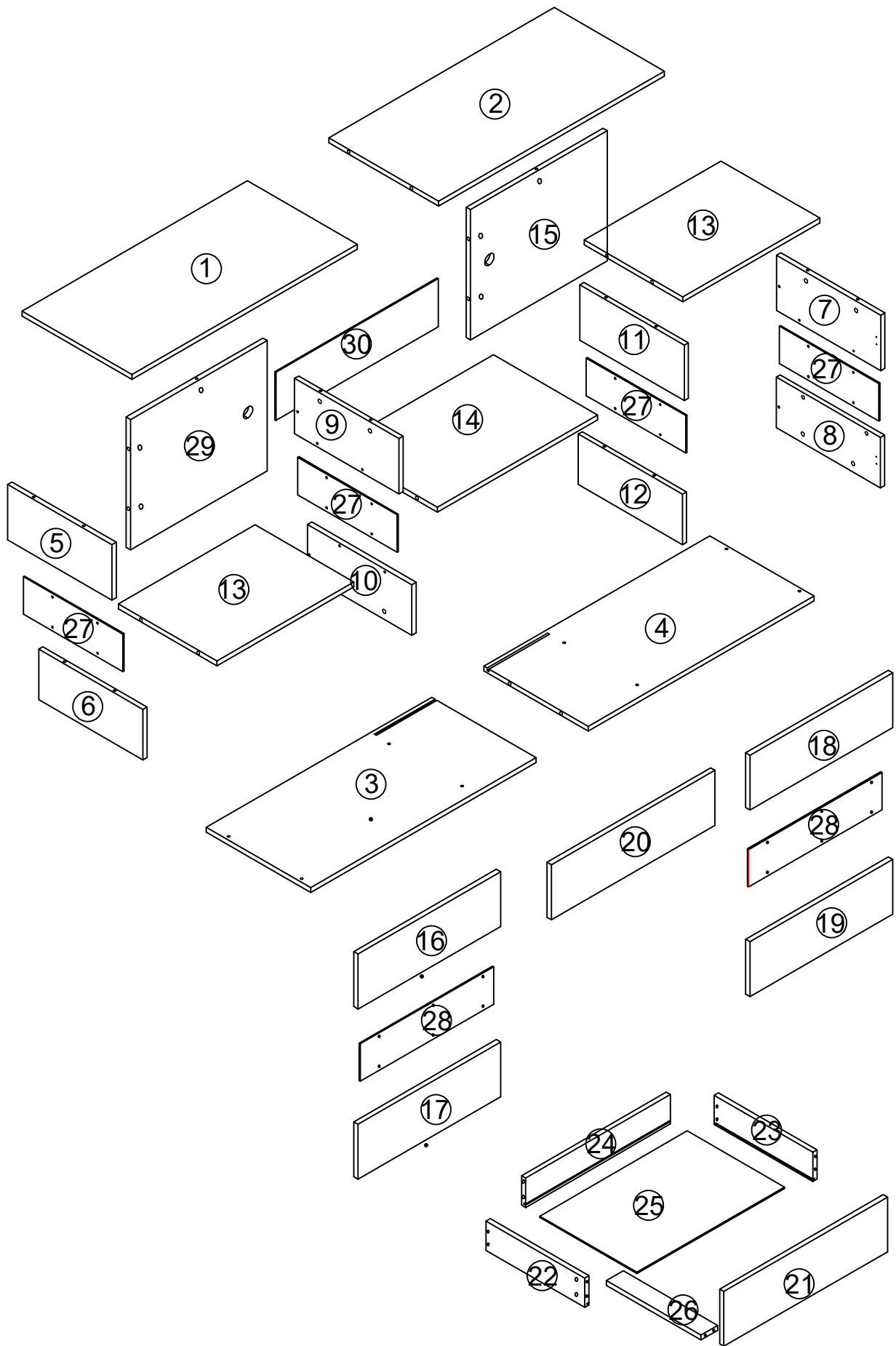

**Advertencia:** Verifique regularmente todos los accesorios y fijaciones para asegurarse de que estén seguros y evitar accidentes. Si falta alguna pieza, está rota, dañada o desgastada, deje de usar el producto hasta que se hayan realizado las reparaciones con piezas autorizadas de fábrica.

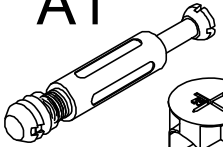
**Advertencia:** No permita que los niños se suban a los muebles, ya que esto puede provocar que se vuelquen y lesiones personales graves. Monte los muebles fuera del alcance de los niños.

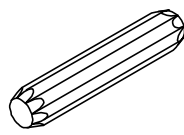
**Advertencia:** No coloque los muebles cerca de fuentes de fuego u objetos de alta temperatura para evitar el riesgo de incendio.

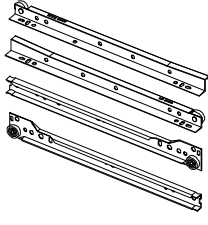
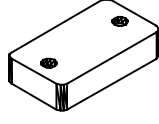
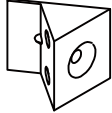
**Advertencia:** Limpie los muebles con un paño húmedo o alcohol, evite usar agentes de limpieza que contengan químicos corrosivos.

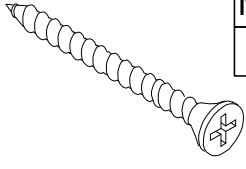
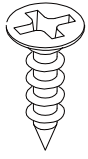
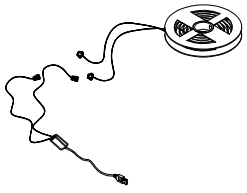

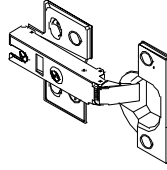
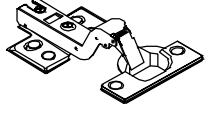
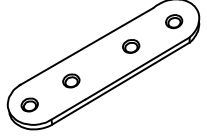
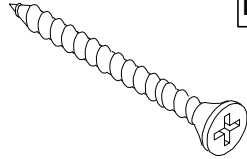
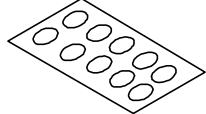
|  |   |   |   |   |   |
|--|---|---|---|---|---|
| <p><b>A1</b></p>  <p><b>A2</b></p>     | <p><b>A</b> x46<br/>+2(spare)</p>           |    | <p><b>B</b> x 6<br/>M8*40<br/>+2(spare)</p>   |    | <p><b>C</b> x28<br/>M6*10<br/>+1(spare)</p> |
|  <p>DR<br/>DL<br/>CR<br/>CL</p>   | <p><b>D</b> x 1<br/>350mm</p>               |    | <p><b>E</b> x 5</p>                           |   | <p><b>F</b> x 4</p>                         |
|   | <p><b>G</b> x10<br/>M4*25<br/>+1(spare)</p> |    | <p><b>H</b> x66<br/>M3.5*14<br/>+2(spare)</p> |    | <p><b>I</b> x 1<br/>450mm</p>               |
|  <p><b>J1</b></p>  <p><b>J2</b></p> | <p><b>J</b> x 3</p>                         |  | <p><b>K</b> x4</p>                            |    | <p><b>L</b> x2</p>                          |
|   | <p><b>M</b> x4</p>                          |  | <p><b>N</b> x 4<br/>M3.5*35</p>               |    | <p><b>O</b> x20</p>                         |

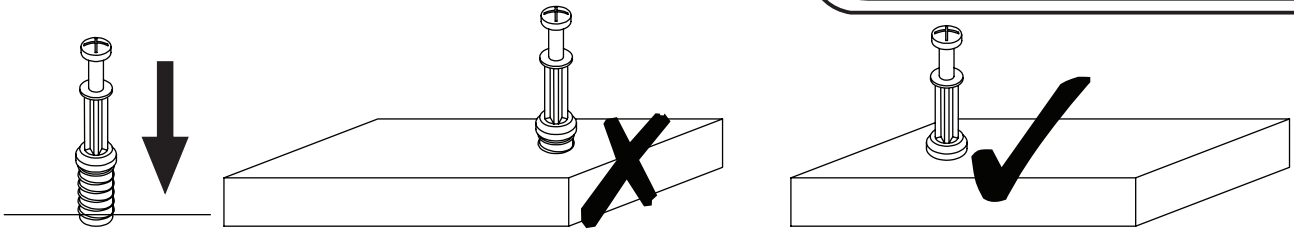

**EN\_QUICKFIT:** Tighten quickfit until shoulder is flush with panel. Do not overtighten or undertighten.

**FR\_RACCORD RAPIDE:** Faites serrer le raccord rapide jusqu'à ce que l'épaulement soit parfaitement encastré dans le panneau. Il ne faut ni trop serrer ni insuffisamment serrer.

**ES\_QUICKFIT:** Apriete quickfit hasta que el hombro se descargue con el panel. NO lo sobreapriete ni lo apriete poco.

**DE\_QUICKFIT:** Ziehen Sie den Quickfit fest, bis die Schulter mit der Platte bündig ist. Bitte nicht zu fest oder zu schwach anziehen.

**IT\_MONTAGGIO RAPIDO:** Stringere il montaggio rapido fino a quando la spalla è a filo con il pannello, non stringere troppo o troppo poco.

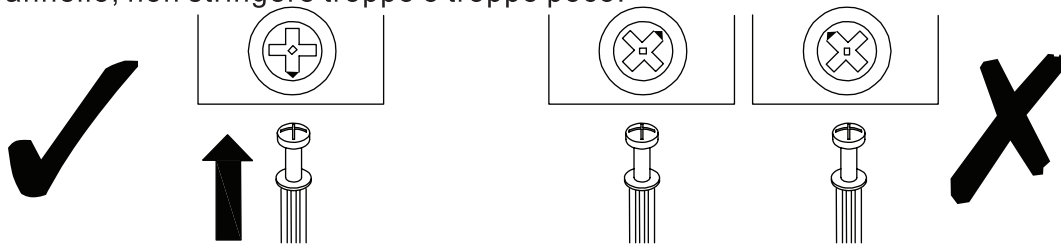

**EN\_CAM LOCK:** When fitting cam lock, ensure starting position is correct before you insert connecting quickfit.

**FR\_SERRURE BATTEUSE:** Avant d'insérer la serrure batteuse, veillez à la bonne orientation avant d'insérer le raccord rapide.

**ES\_CIERRE DE LA CÁMARA:** Cuando instale el cierre de la cámara, asegúrese de que la posición de inicio es correcta antes de que inserte el quickfit conector.

**DE\_CAM-LOCK:** Achten Sie bei der Montage des Cam-Locks auf die richtige Ausgangsposition, bevor Sie den Quickfit einsetzen.

**IT\_BLOCCAGGIO A CAMMA:** Quando si monta il bloccaggio a camma, assicurarsi che la posizione iniziale sia corretta prima di inserire il montaggio rapido di collegamento.

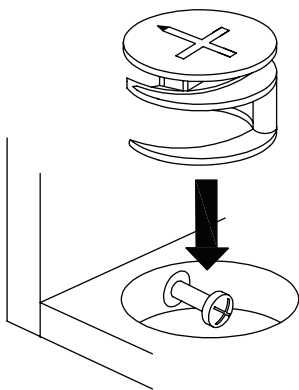

**EN\_Quickfit head** should be in the centre of the cam lock when the two panels are joined.

Cam lock should be inserted before quickfit.

**FR\_**Lorsque les deux panneaux sont assemblés, la tête du raccord rapide doit reposer au centre de la serrure batteuse. Il faut insérer la serrure batteuse avant le raccord rapide.

**ES\_**El cabezal del quickfit debe estar en el centro del cierre de la cámara cuando se unan los dos paneles.

Se debe insertar el cierre de la cámara antes que el quickfit.

**DE\_**Der Quickfit-Kopf sollte sich in der Mitte des Cam-Locks befinden, wenn die beiden Platten zusammengefügt sind. Der Cam-Lock sollte vor dem Quickfit eingesetzt werden.

**IT\_**La testa del montaggio rapido deve trovarsi al centro del bloccaggio a camma quando i due pannelli sono uniti.

Il Bloccaggio a Camma deve essere inserito prima del montaggio rapido.

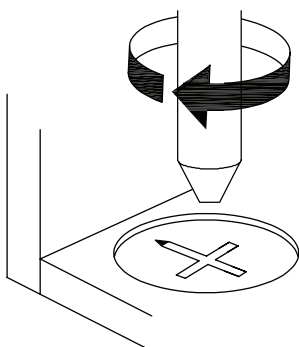

**EN\_**Turn cam lock clockwise to tighten.

**FR\_**Faites tourner la serrure batteuse dans le sens des aiguilles d'une montre pour la resserrer.

**ES\_**Gire el cierre de la cámara en sentido horario para apretarlo.

**DE\_**Drehen Sie den Cam-Lock im Uhrzeigersinn, um ihn festzuziehen.

**IT\_**Ruotare il bloccaggio a camma in senso orario per stringere.

**EN** It may be necessary to adjust the hinges so that the doors align. Use the instructions below as a guide.

**FR** Il est parfois nécessaire d'ajuster les charnières pour un meilleur alignement des portes. Servez-vous des instructions ci-dessous comme guide.

**ES** Puede que sea necesario ajustar los quicios de forma que se alineen las puertas. Use las instrucciones que aparecen debajo como guía.

**DE** Möglicherweise müssen Sie die Scharniere so einstellen, dass die Türen ausgerichtet sind. Verwenden Sie die nachstehenden Anweisungen als Leitfaden.

**IT** Potrebbe essere necessario regolare le cerniere in modo che le porte siano allineate. Per fare ciò attenersi alle istruzioni sottostanti.

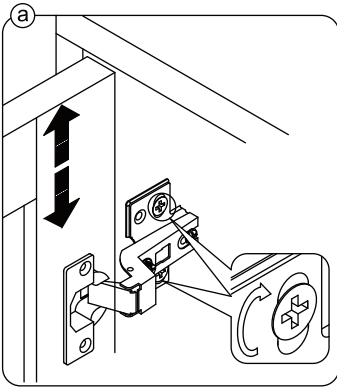

**EN** To adjust the door vertically loosen the screw as shown and move up and down as needed.

**FR** Si vous souhaitez régler la porte **verticalement**, desserrez la vis comme indiqué et déplacez la porte de haut en bas selon les besoins.

**ES** Para ajustar la puerta **verticalmente** afloje el tornillo tal y como se muestra y muévelo hacia arriba o hacia abajo según sea necesario.

**DE** Um die Tür **vertikal** auszurichten, lösen Sie die Schraube wie abgebildet und bewegen Sie sie nach Bedarf nach oben oder nach unten.

**IT** Per allineare la porta **verticalmente** allentare la vite come mostrato e spostarla in alto o in basso secondo necessità.

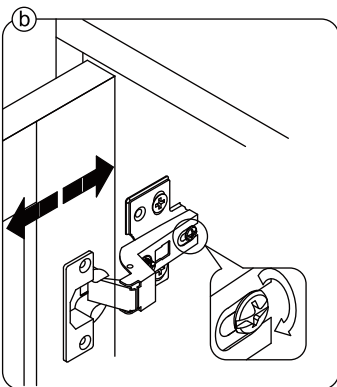

**EN** To adjust the gap from the door to the main frame turn the screw clockwise or anti-clockwise as needed.

**FR** Si vous souhaitez ajuster l'**écart** entre la porte et le cadre principal, tournez la vis dans le sens des aiguilles d'une montre ou dans le sens inverse, si nécessaire.

**ES** Para ajustar el **espacio** desde la puerta al marco principal, gire el tornillo en sentido horario o antihorario, según se necesite.

**DE** Um den **Abstand** von der Tür zum Hauptrahmen auszurichten, drehen Sie die Schraube je nach Bedarf im oder gegen den Uhrzeigersinn.

**IT** Per regolare lo **spazio** tra la porta e il telaio principale, avvitarlo o svitarlo la vite secondo necessità.

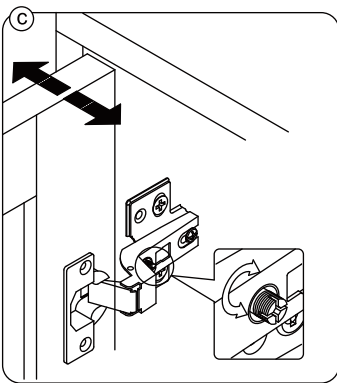

**EN** To adjust the door laterally adjust the screw as shown by turning clockwise or anti-clockwise.

**FR** Si vous souhaitez ajuster la porte **latéralement**, ajustez la vis comme indiqué en tournant dans le sens des aiguilles d'une montre ou dans le sens inverse des aiguilles d'une montre.

**ES** Para ajustar la puerta **lateralmente** ajuste el tornillo tal y como se muestra girándolo en sentido horario y antihorario.

**DE** Um die Tür **seitlich** auszurichten, stellen Sie bitte die Schraube wie abgebildet durch Drehen im oder gegen den Uhrzeigersinn ein.

**IT** Per allineare la porta **lateralmente** regolare la vite come mostrato, avvitarla o svitarla.

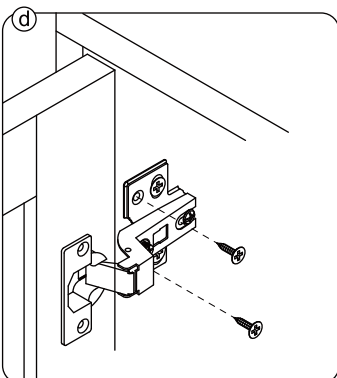

**EN** Please fix other screws

**FR** Merci de serrer les autres vis.

**ES** Fije los demás tornillos

**DE** Befestigen Sie bitte die anderen Schrauben

**IT** Fissare le altre viti

| BOX<br>1-2 | SKU:N625P183801<br>N605P439610 | BOX<br>2-2   | SKU:N625P183804<br>N605P439611 |
|------------|--------------------------------|--|--------------------------------|
| 1          | 800*391*15=1PC                 | 5  | 170*370*15=1PC                 |
| 2          | 800*391*15=1PC                 | 6  | 155*370*15=1PC                 |
| 3          | 800*370*15=1PC                 | 7  | 170*370*15=1PC                 |
| 4          | 800*370*15=1PC                 | 8  | 155*370*15=1PC                 |
| 14         | 568*369*15=1PC                 | 9  | 170*370*15=1PC                 |
| 16         | 506*168.5*15=1PC               | 10   | 155*370*15=1PC                 |
| 17         | 506*168.5*15=1PC               | 11   | 170*370*15=1PC                 |
| 18         | 506*168.5*15=1PC               | 12   | 155*370*15=1PC                 |
| 19         | 506*168.5*15=1PC               | 13   | 485*350*15=2PCS                |
| 20         | 580*168.5*15=1PC               | 15   | 485*400*15=1PC                 |
| 21         | 580*168.5*15=1PC               | 24   | 513*90*15=1PC                  |
| 22         | 350*90*15=1PC                  | 29   | 485*400*15=1PC                 |
| 23         | 350*90*15=1PC                  |  <p>Hardware Kit</p> |                                |
| 25         | 523*345*3=1PC                  |  |                                |
| 26         | 335*60*15=1PC                  |  |                                |
| 30         | 576*148*3=1PC                  |  |                                |
| 27         | 353*115*4=4PCS                 |  |                                |
| 28         | 475*115*4=2PCS                 |  |                                |

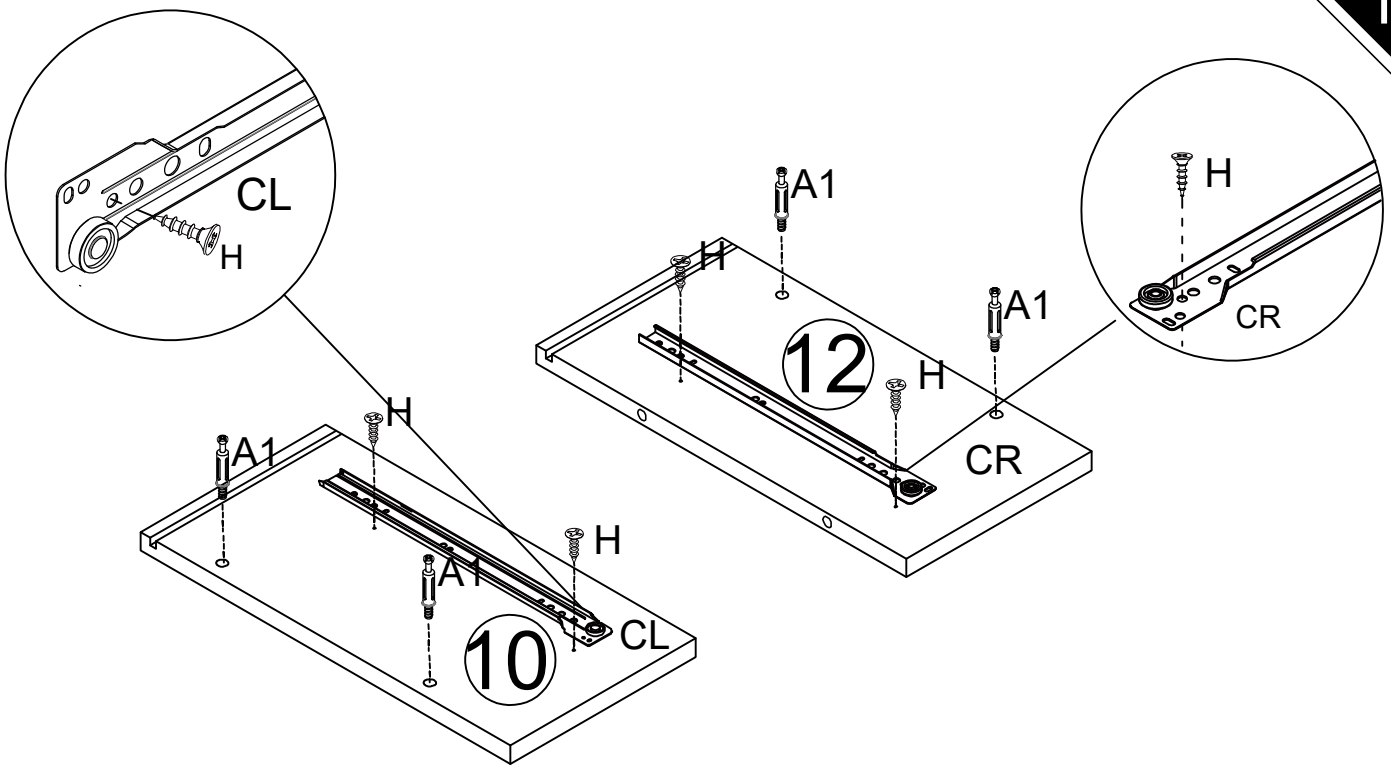

- A1** x 4
- H** x 4  
M3.5\*14
- D** x 1  
350mm
- CR**
- CL**

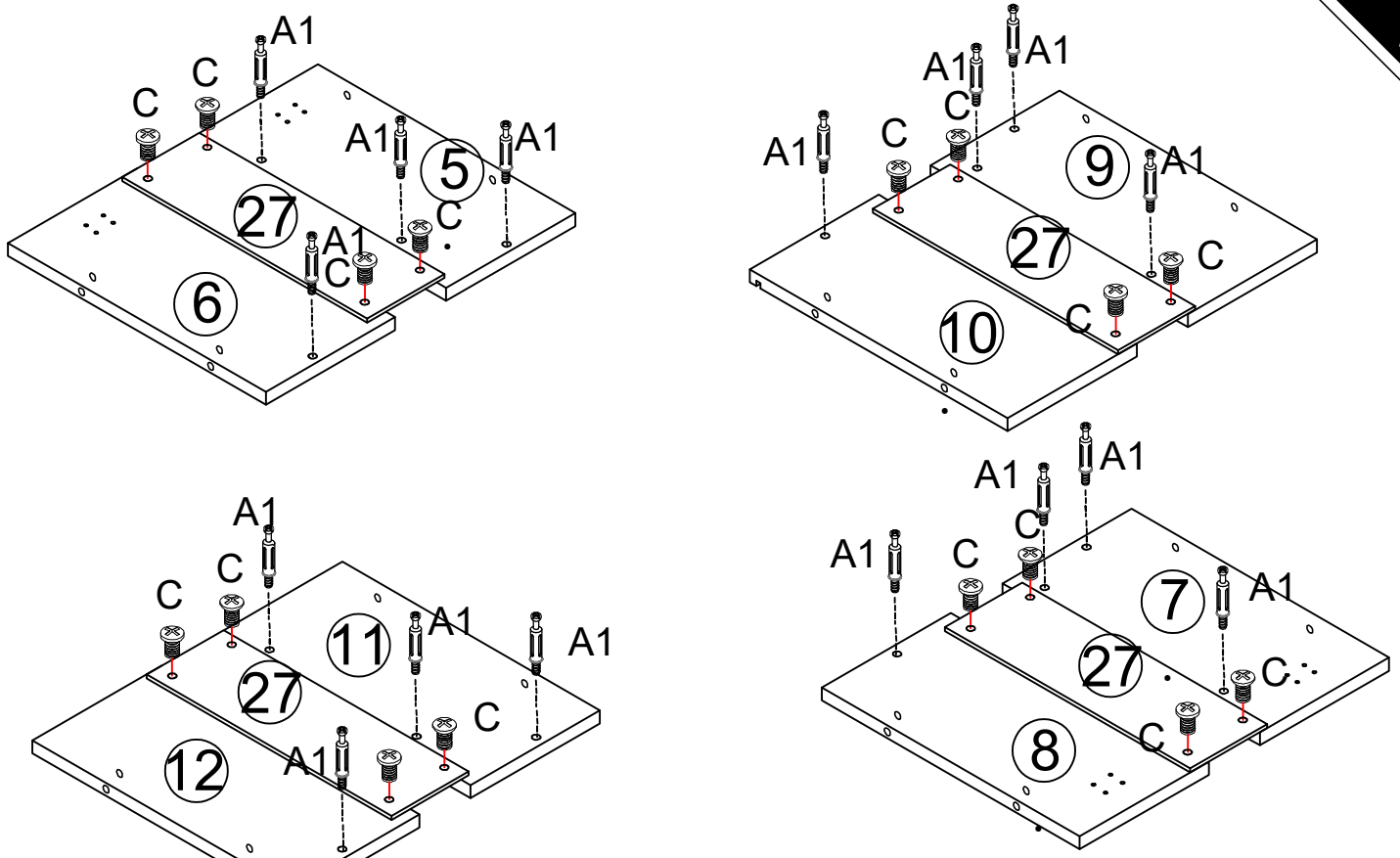

- A1** x 16
- C** x 16  
M6\*10

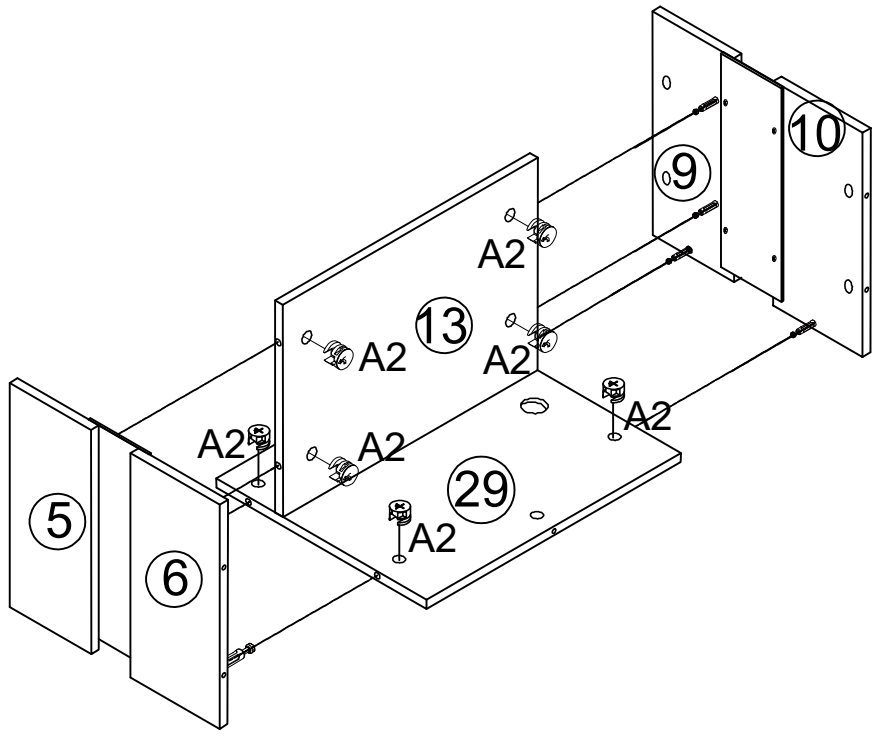

A2 x8

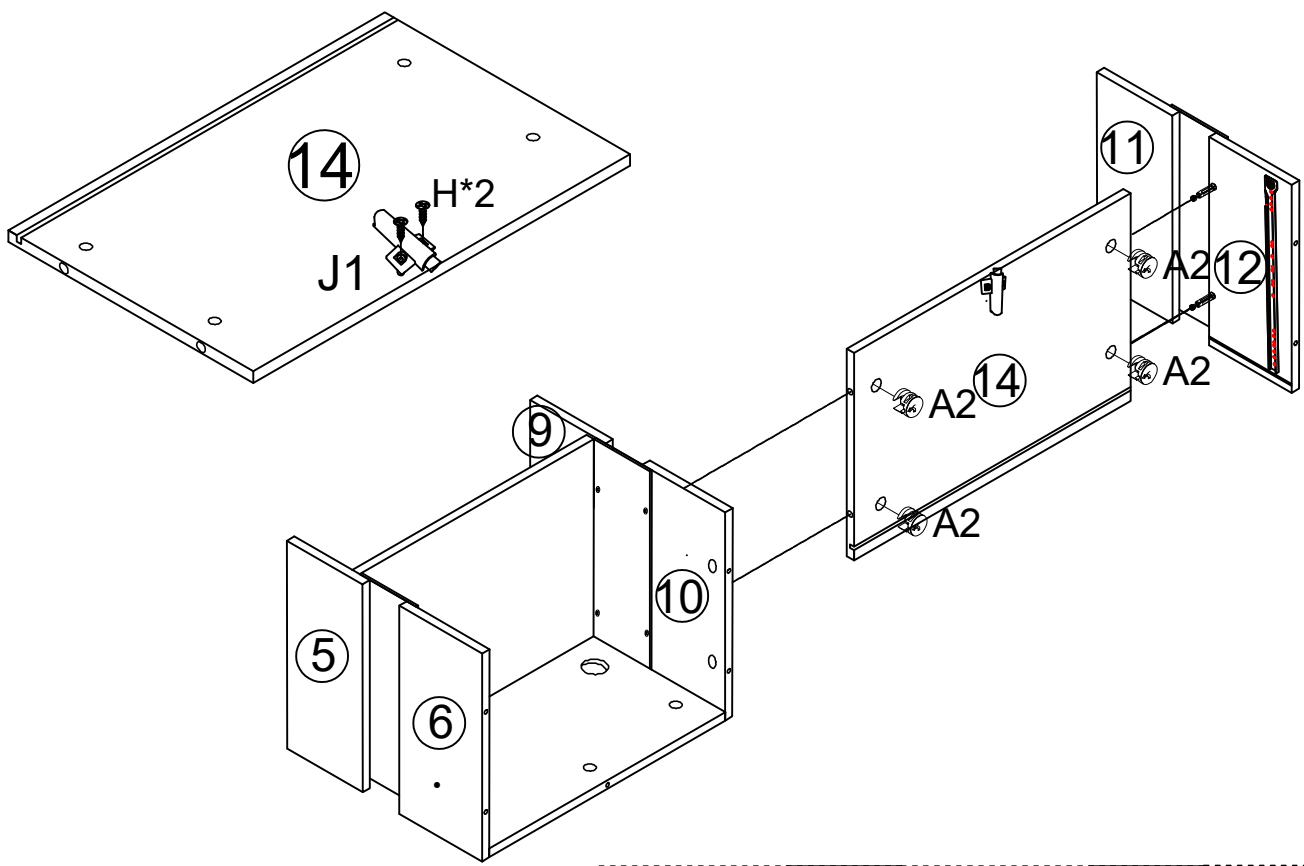

J1 x1

H x2  
M3.5\*14

A2 x4

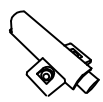

5

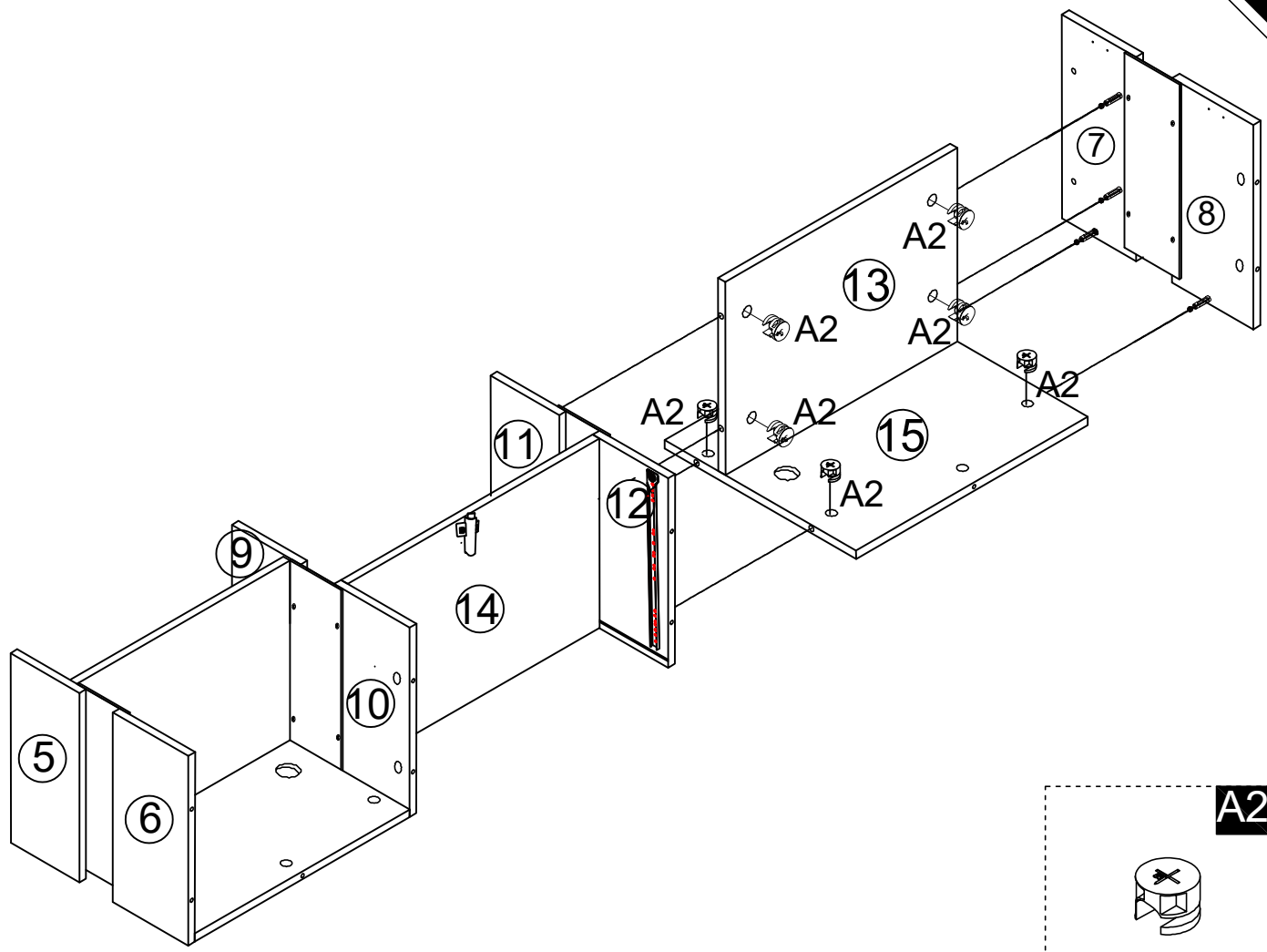

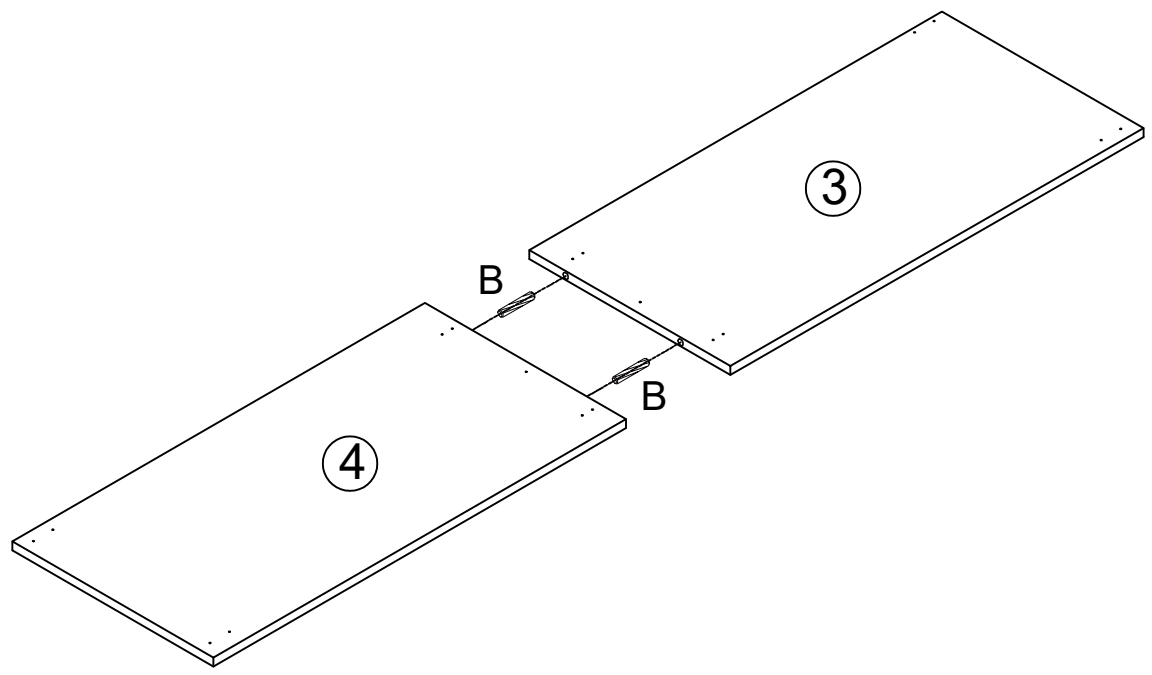

6

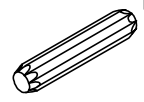

B x2  
M8\*40

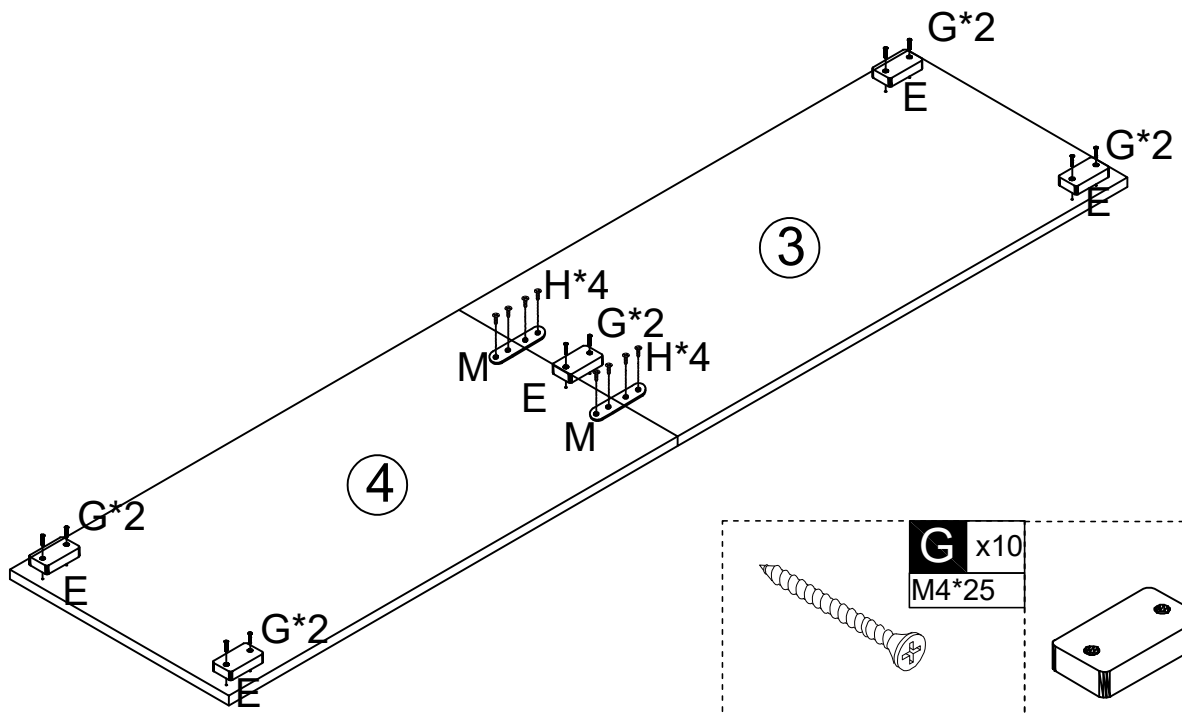

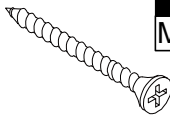
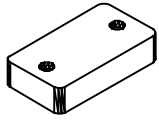

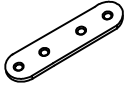
|  |  |
|--|--|
| <b>G</b> x10<br>M4*25  | <b>E</b> x5  |
|    |   |
| <b>H</b> x8<br>M3.5*14   | <b>M</b> x2  |
|  |  |

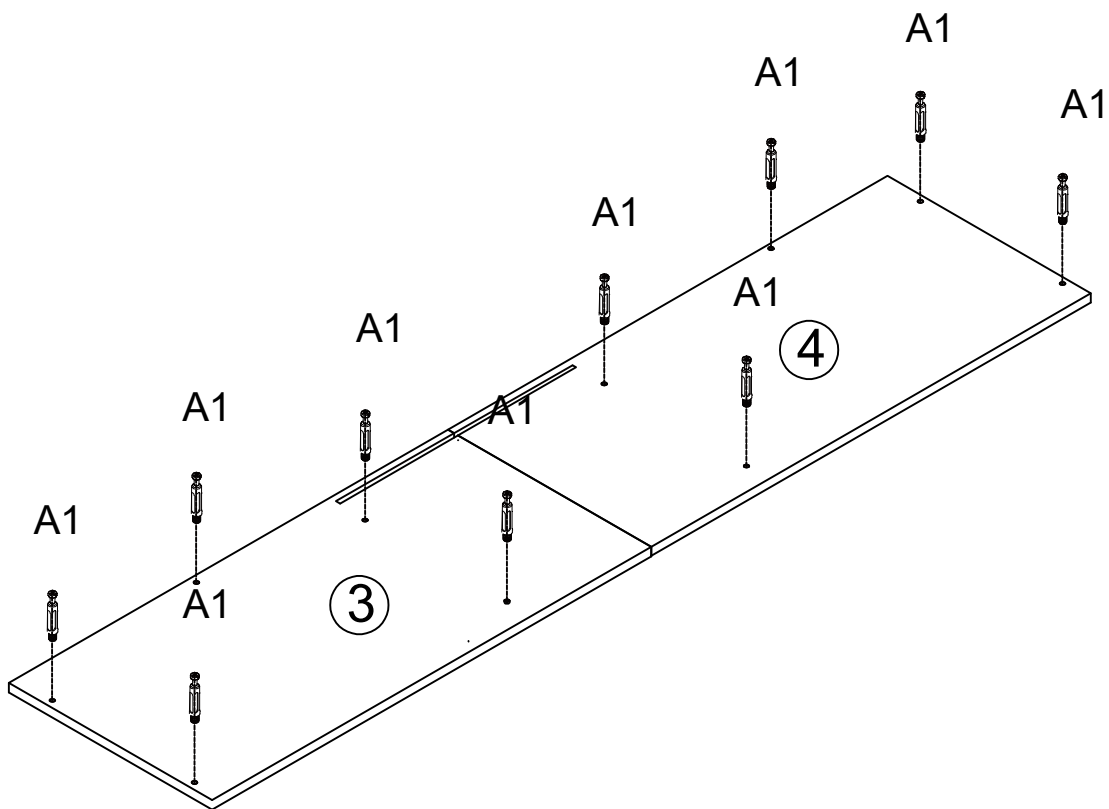

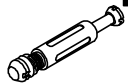
|   |
|---|
| <b>A1</b> x10   |
|  |

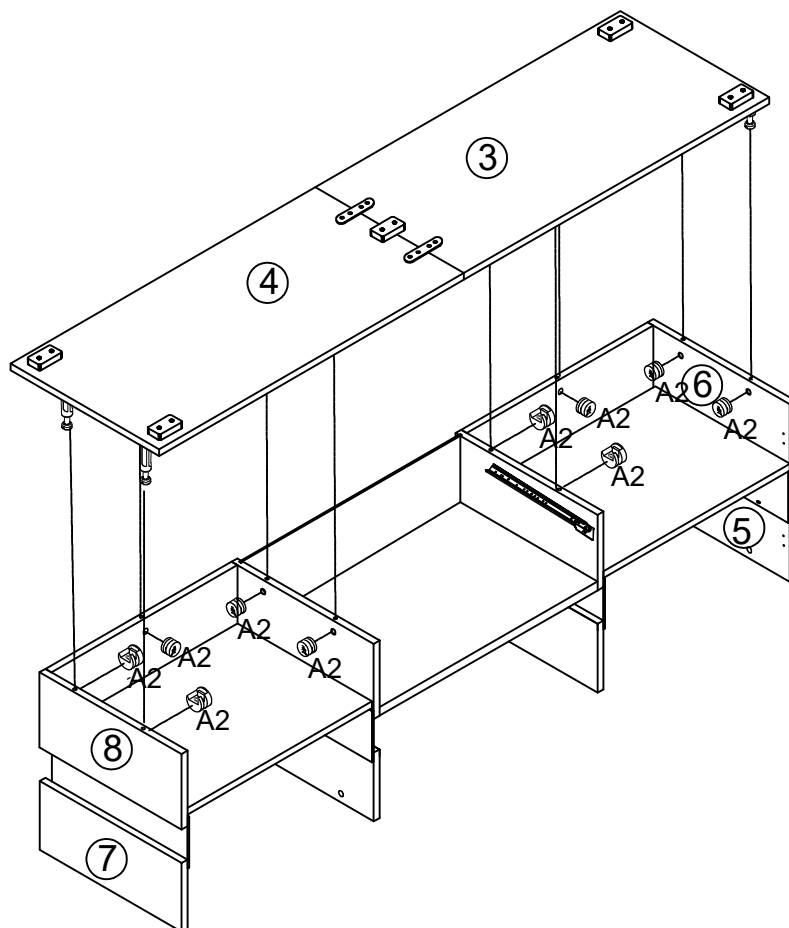
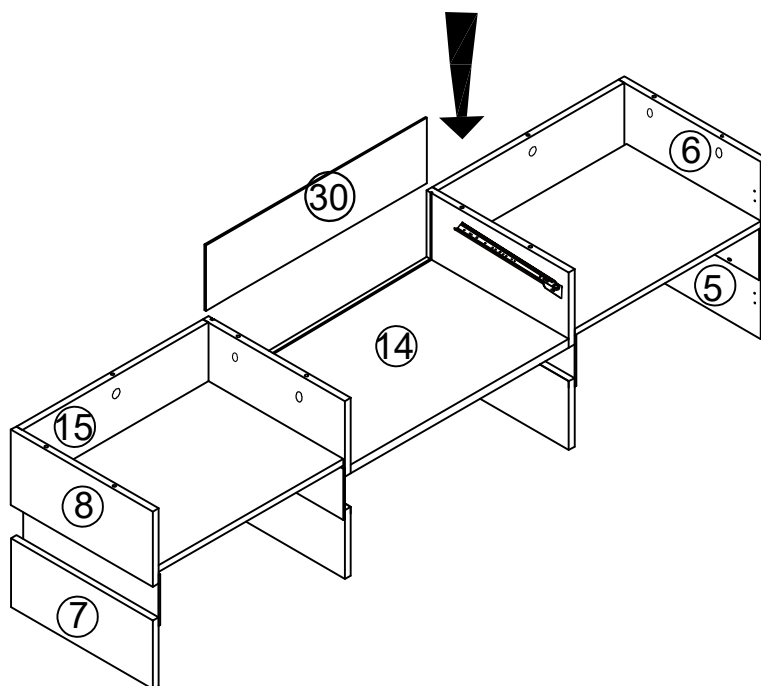

A2 x10



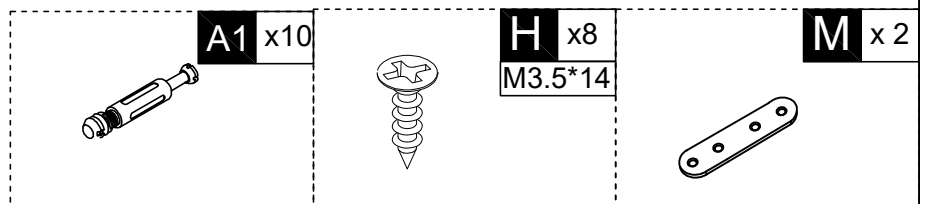
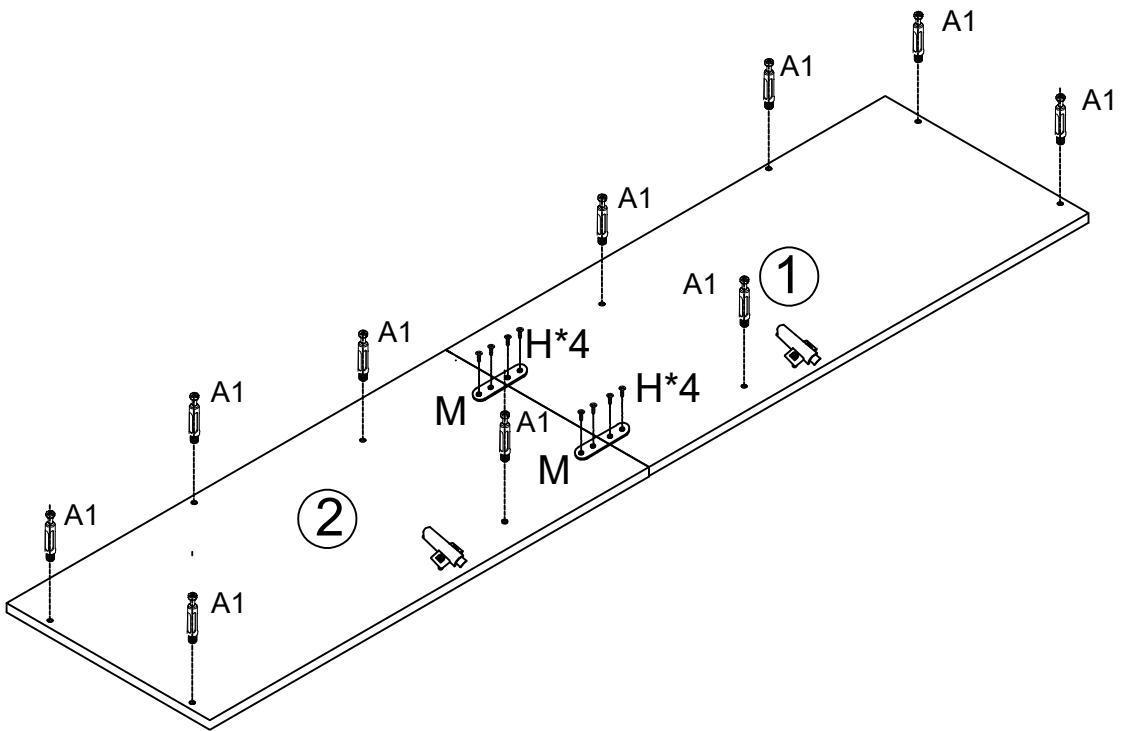
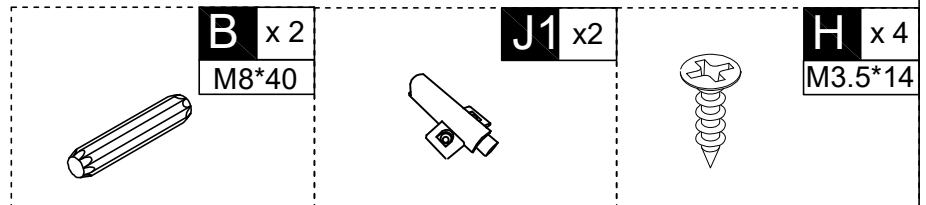
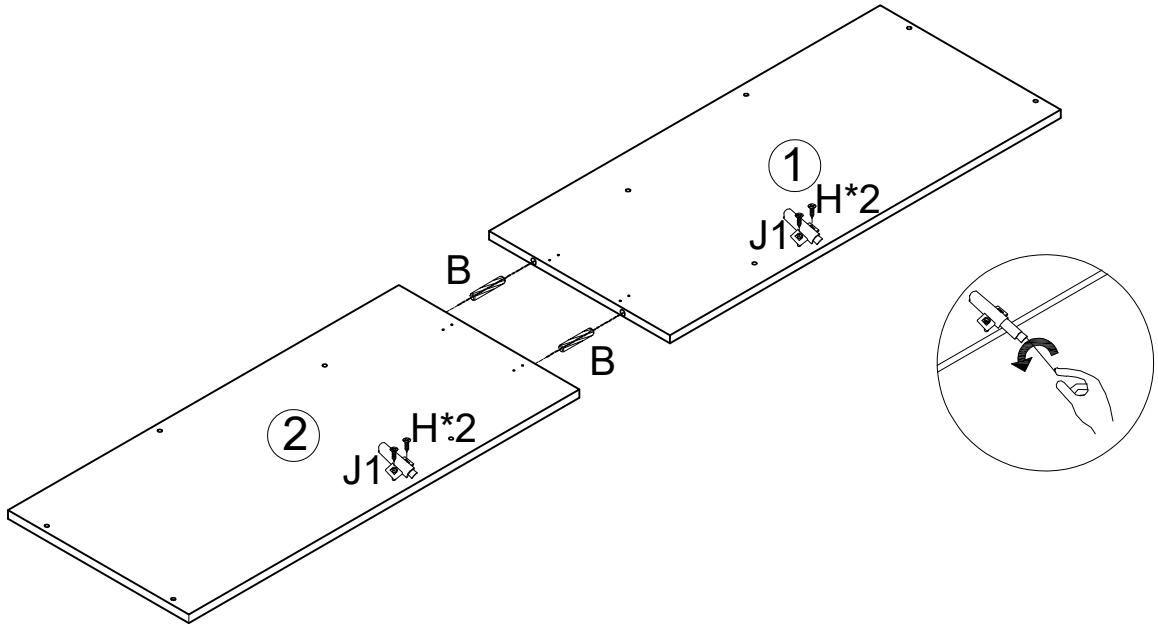

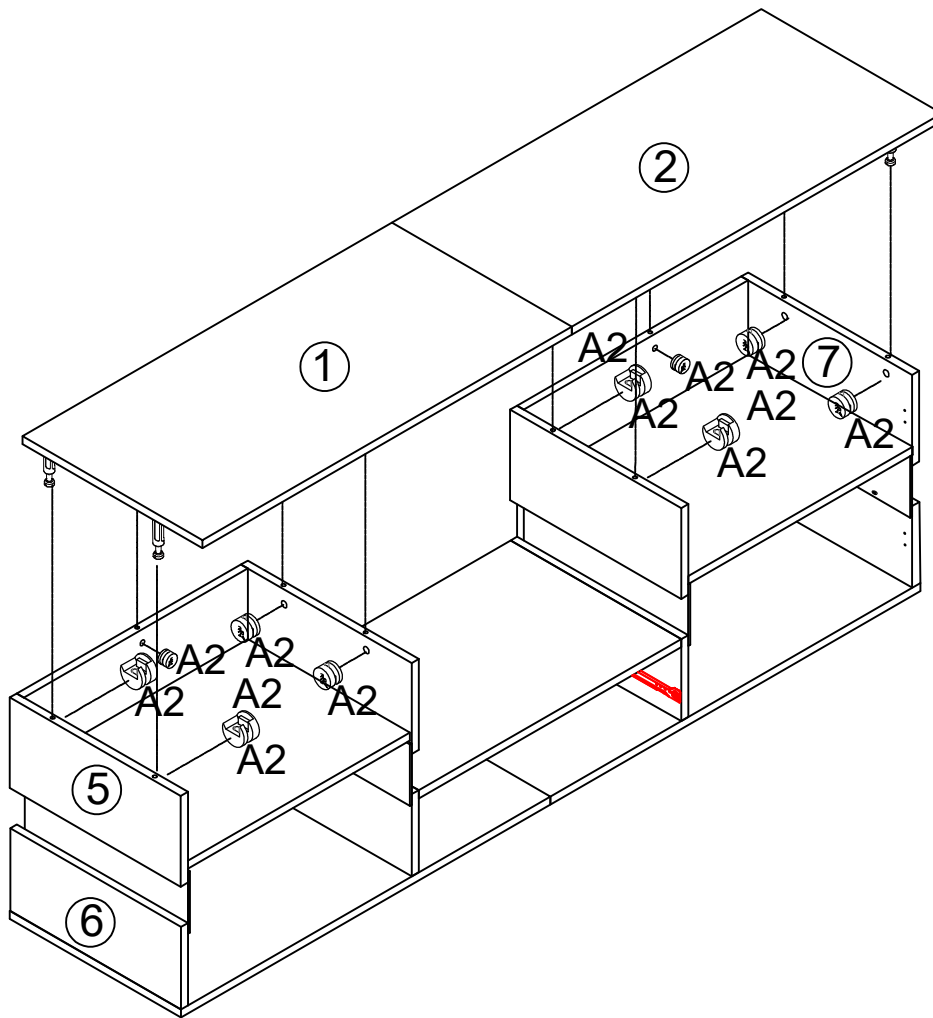

A2 x10

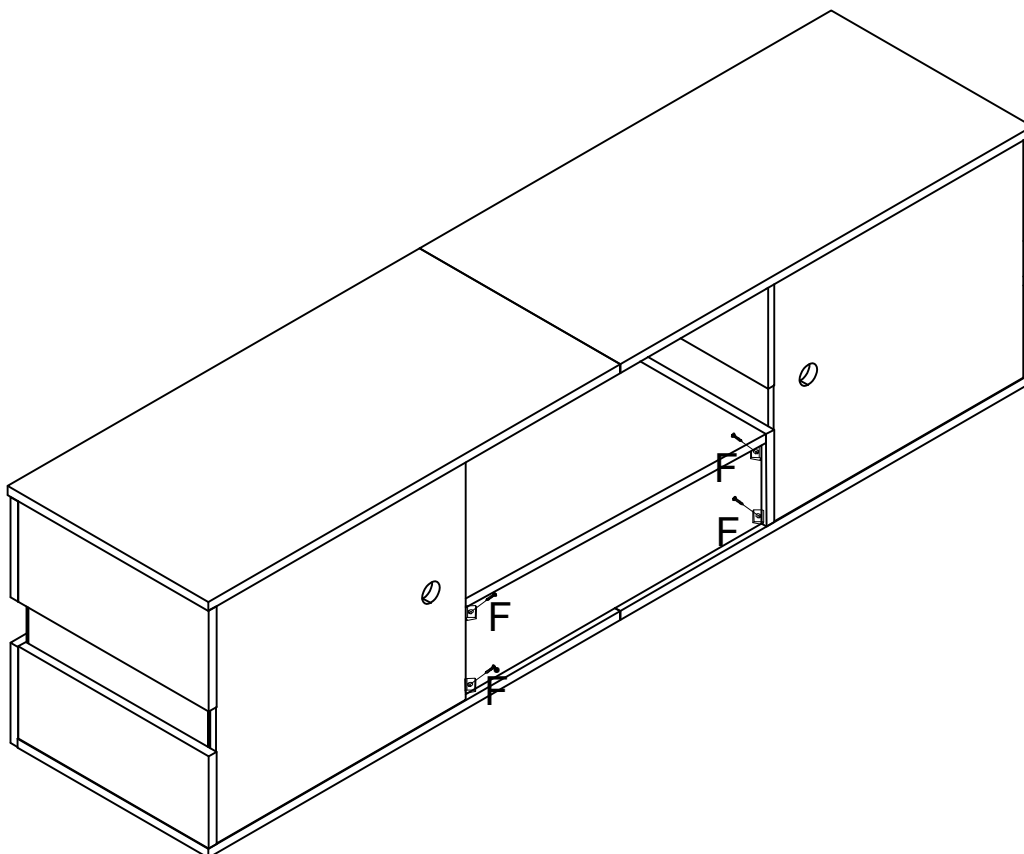

F x4

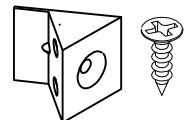

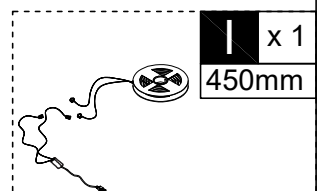
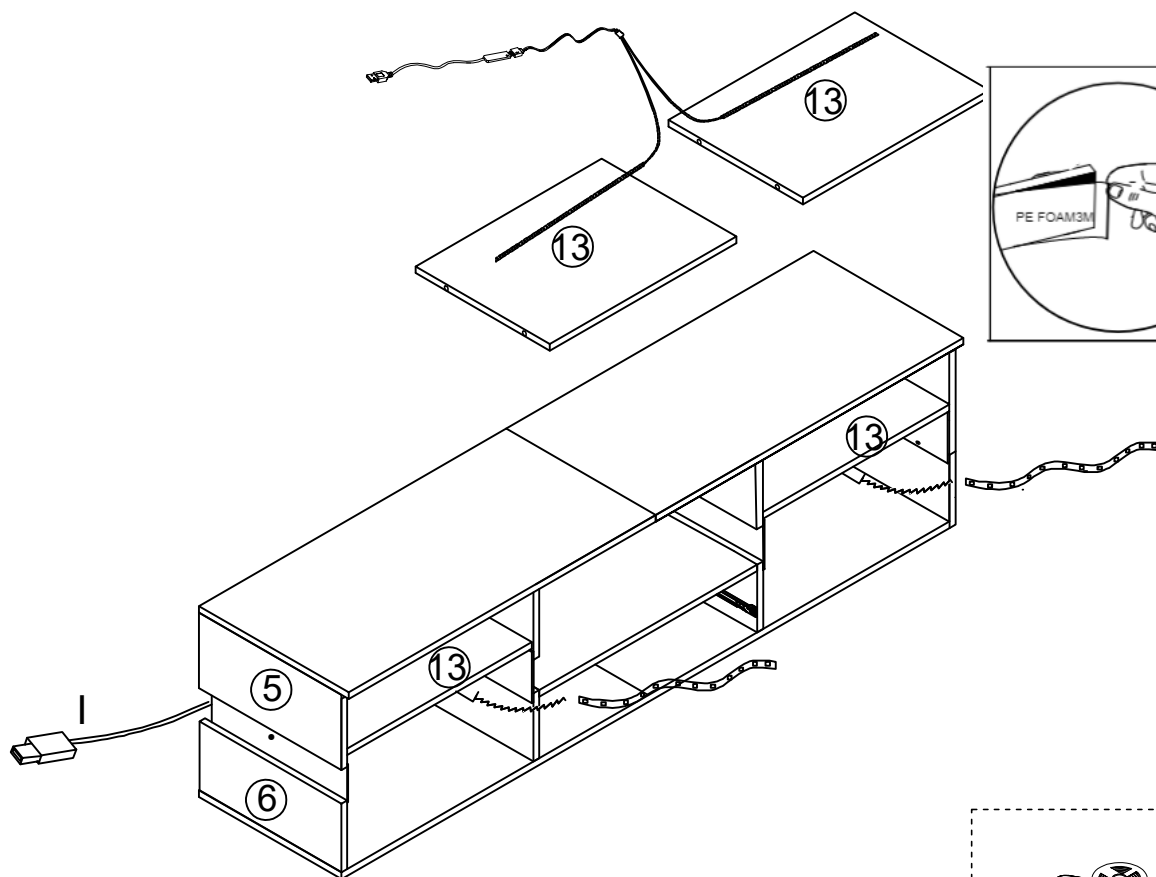
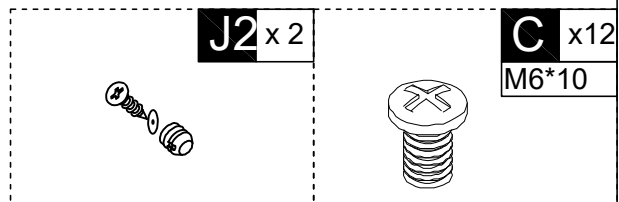
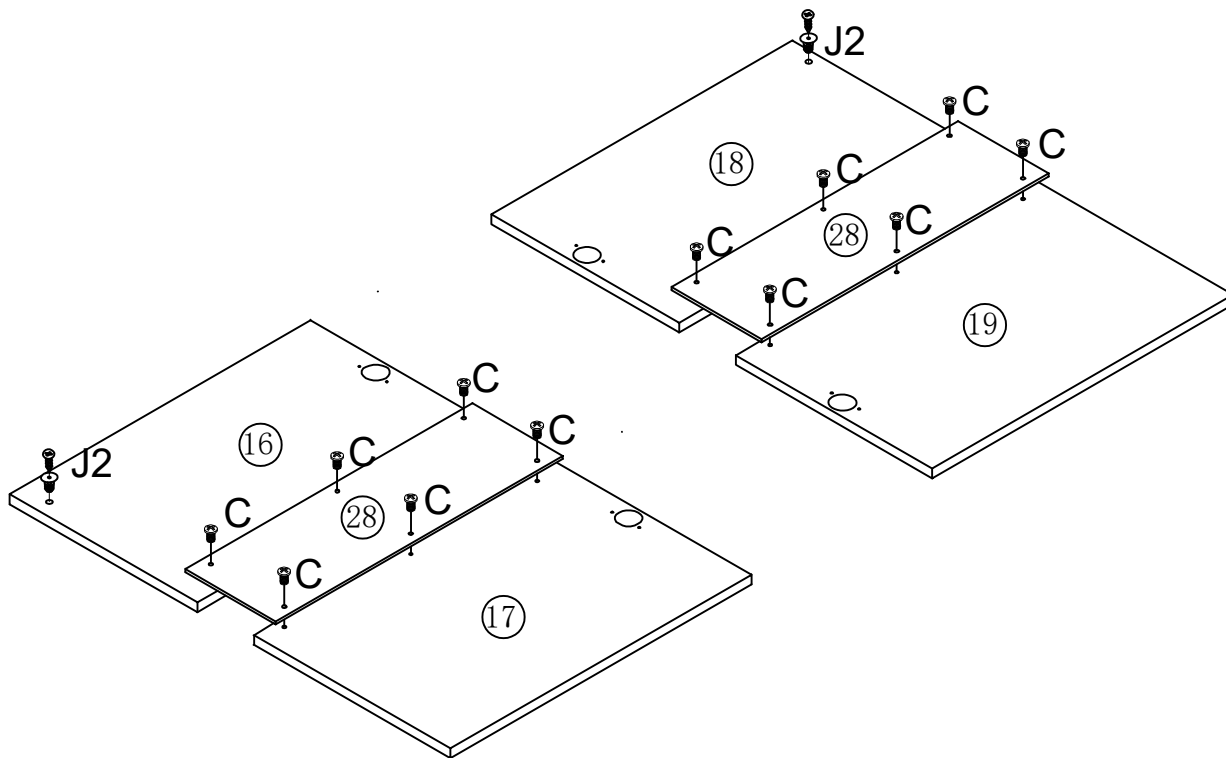

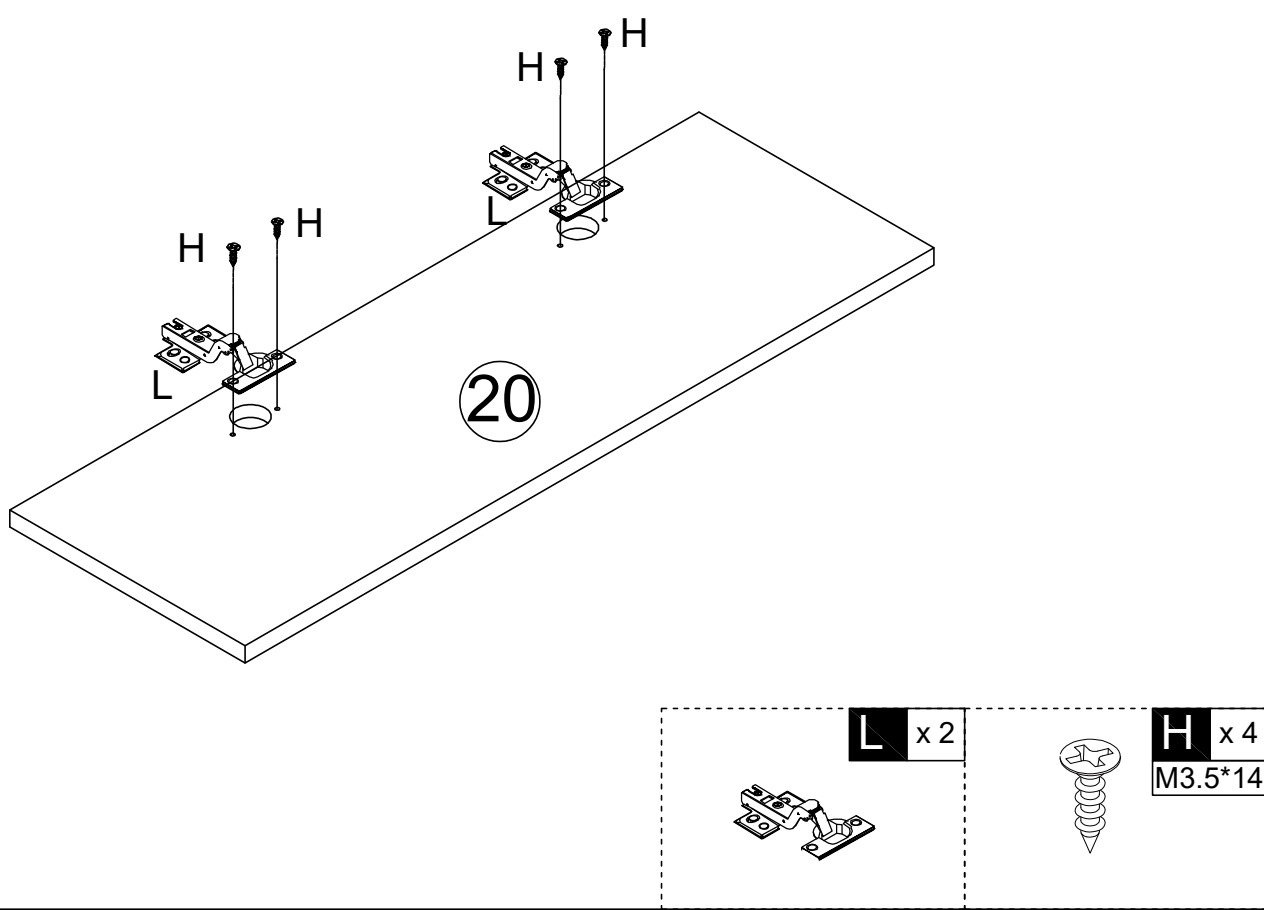
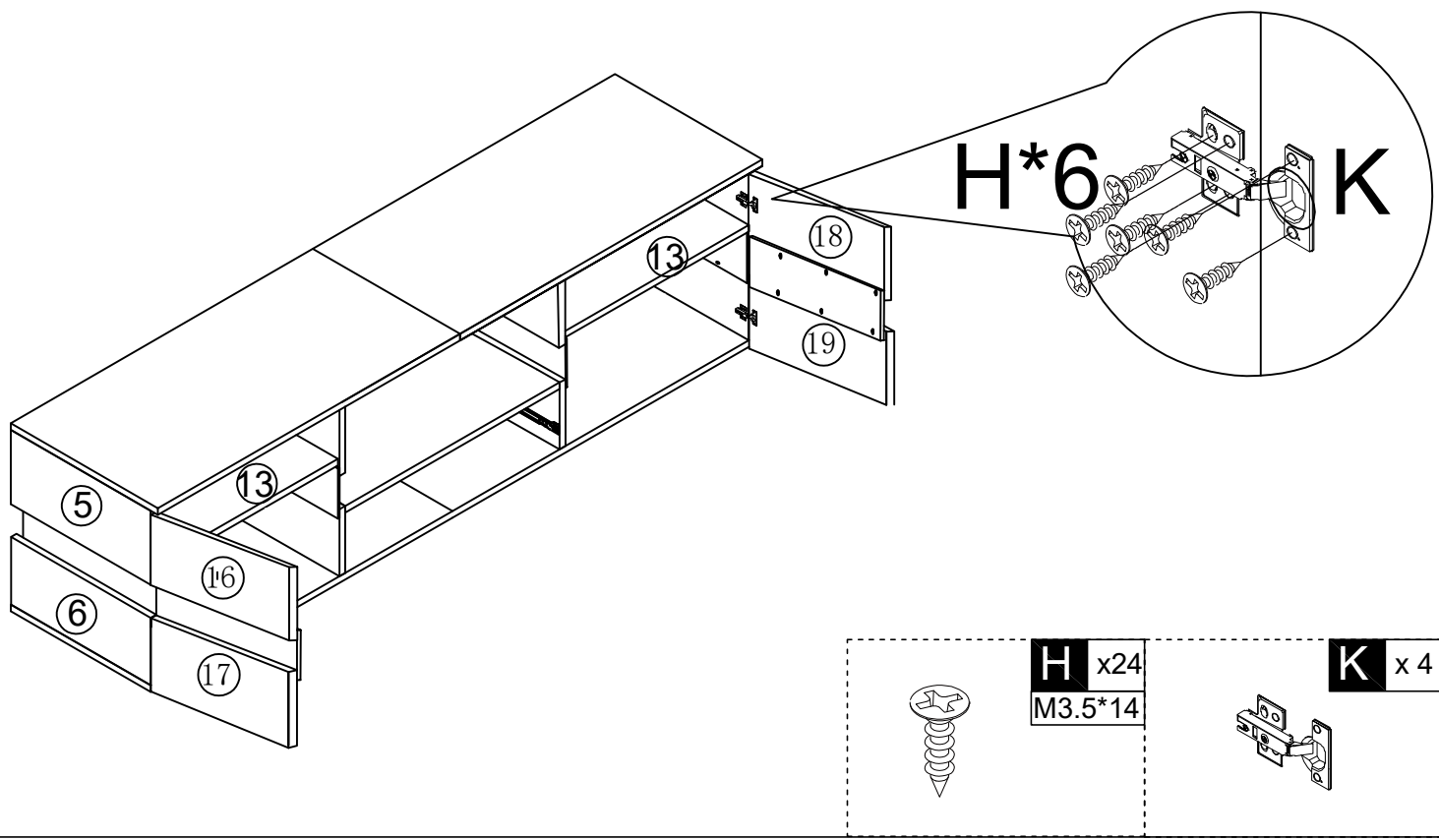

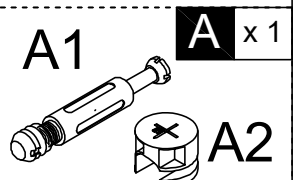
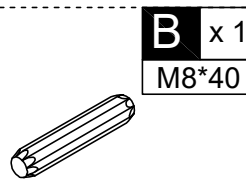
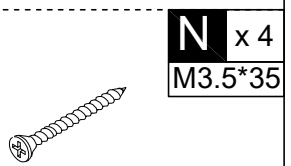
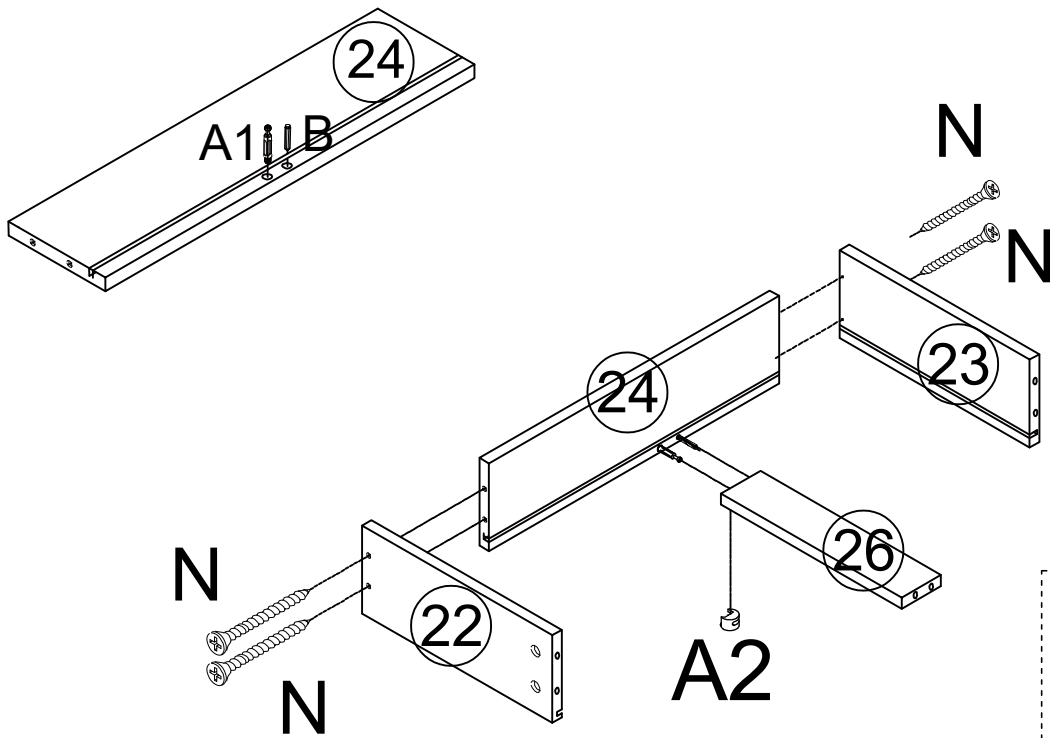
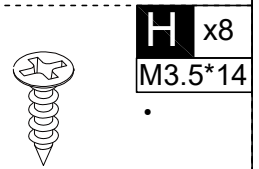
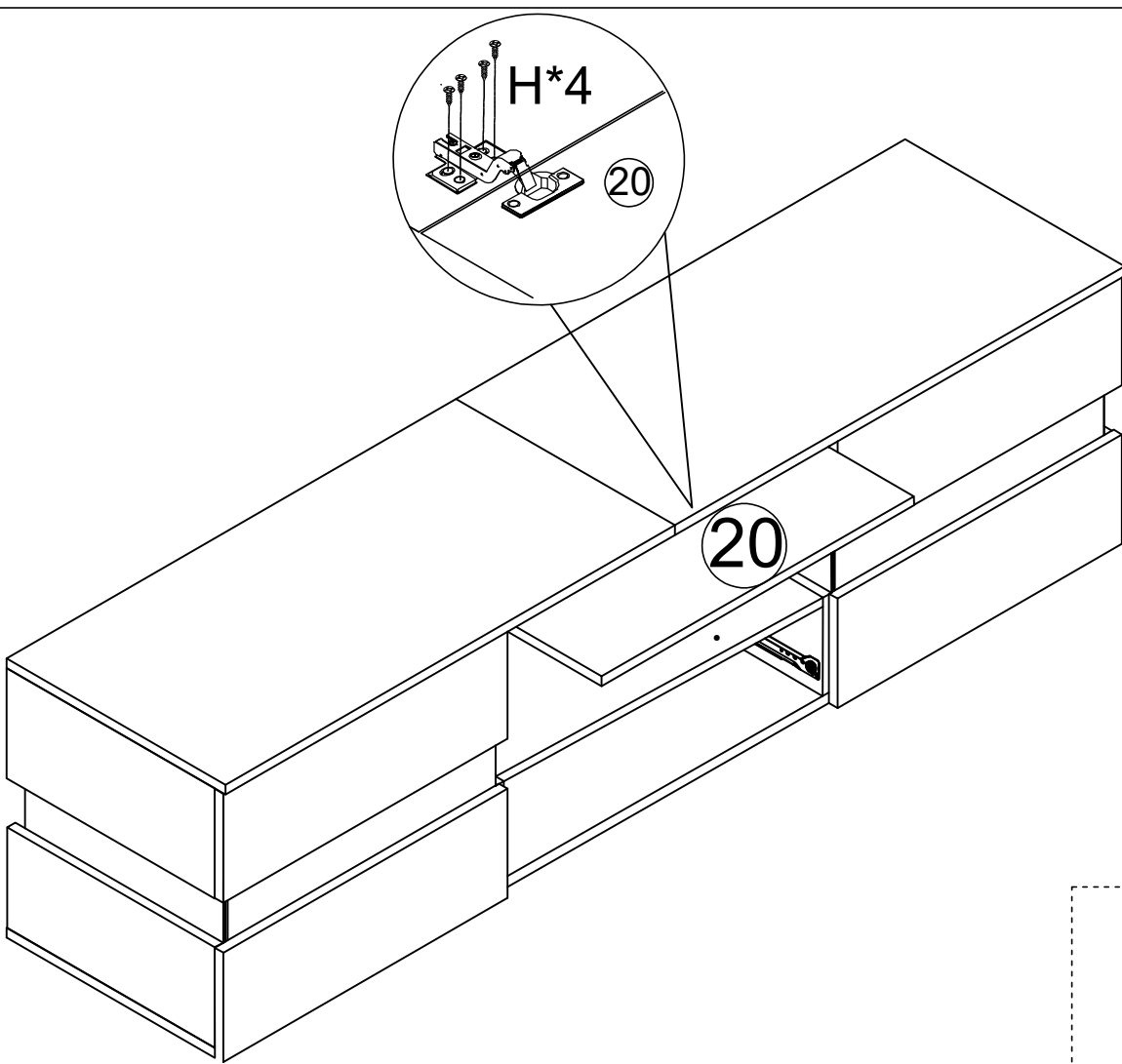

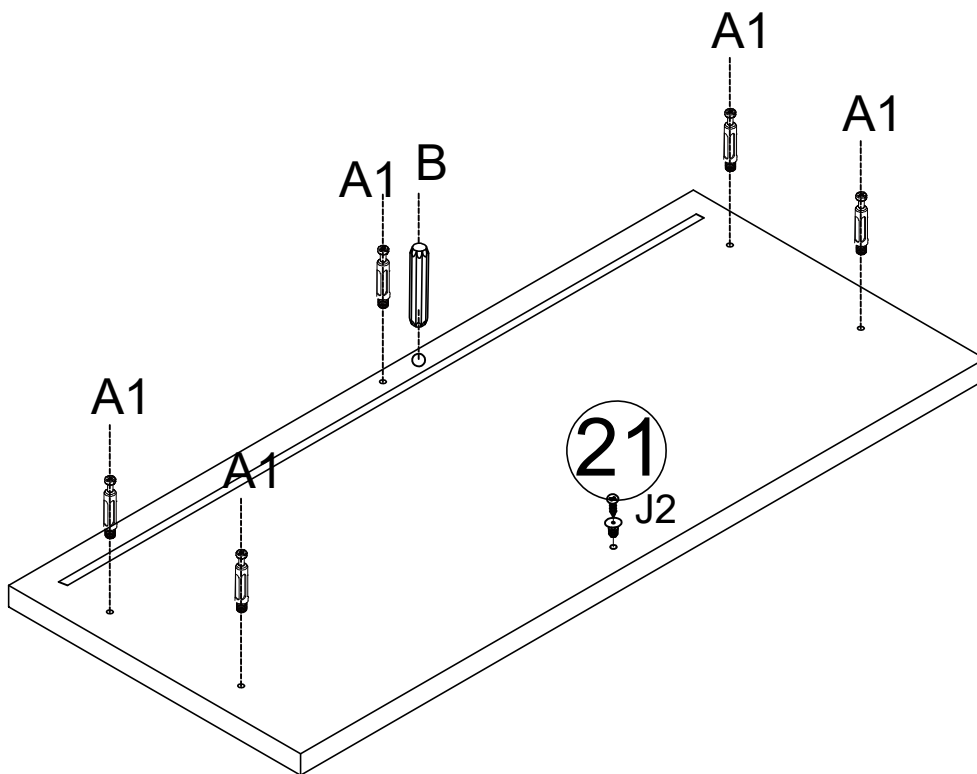

J2 x 1



A1 x 5



B x 1

M8\*40

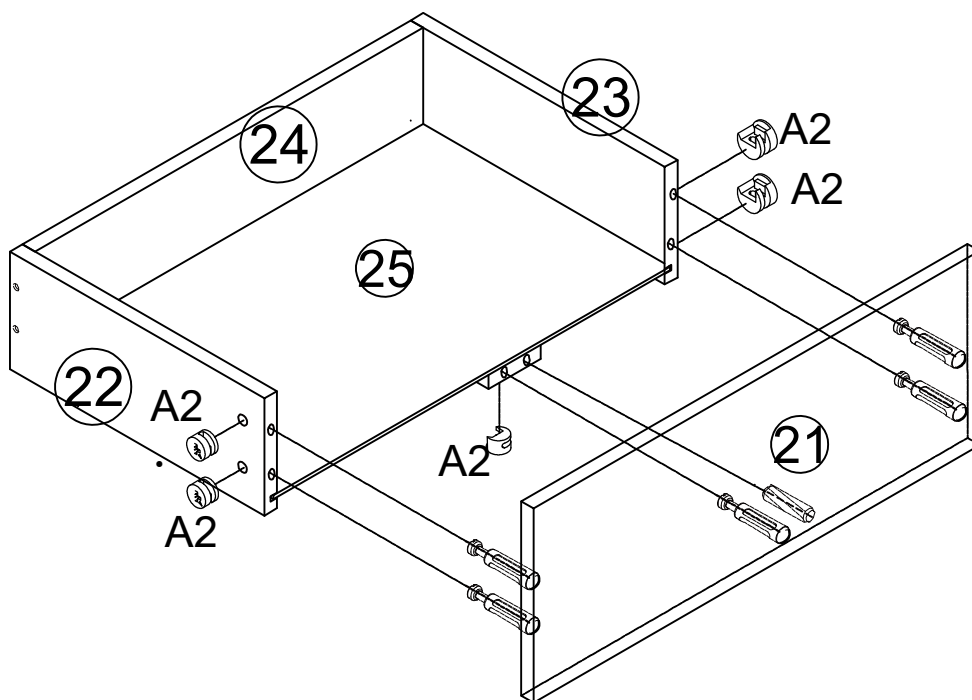
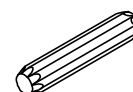

A2 x 5



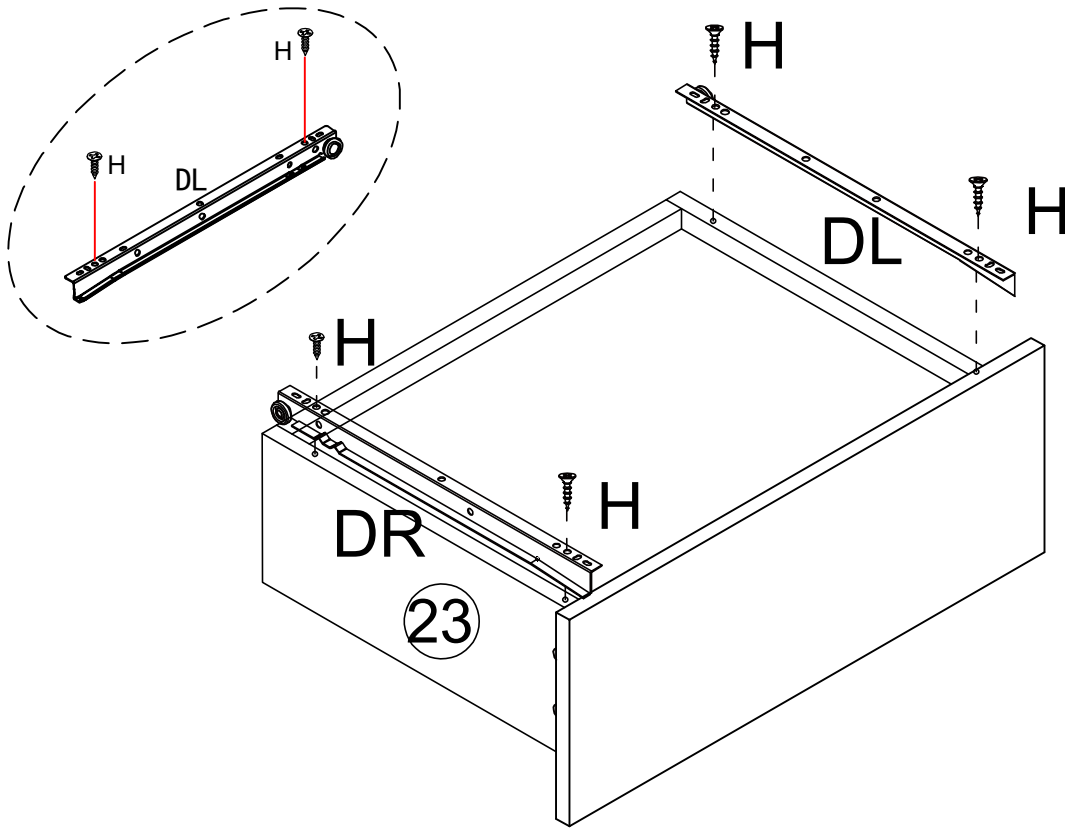

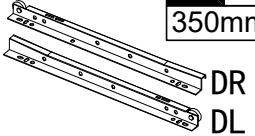
|  |             |  |               |
|--|-------------|--|---------------|
|  | <b>H</b> x4 |  | <b>D2</b> x 1 |
|  | M3.5*14     |  | 350mm         |

DR  
DL

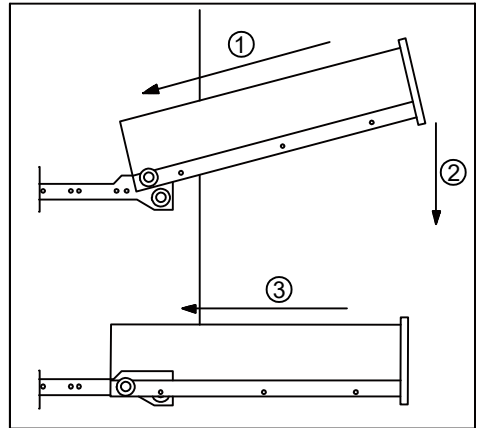
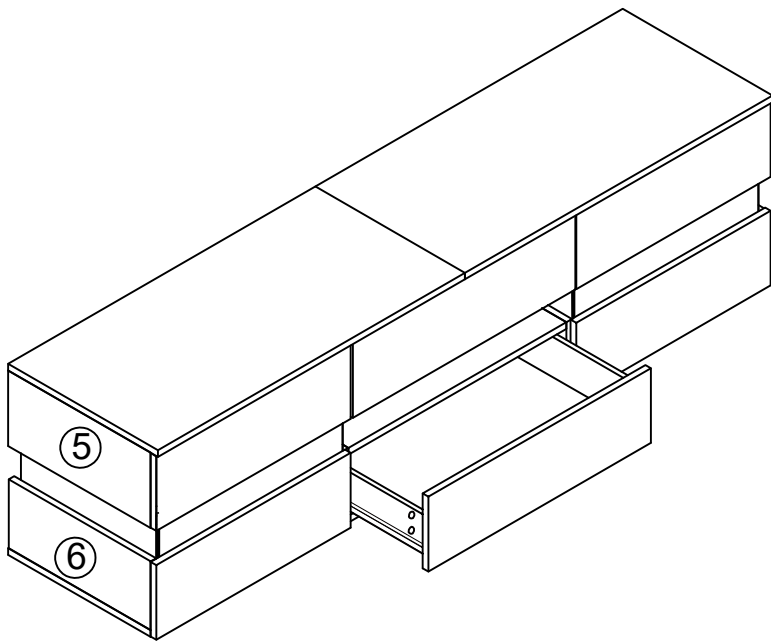

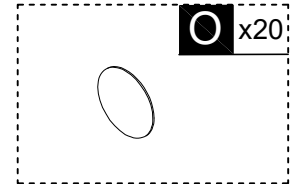
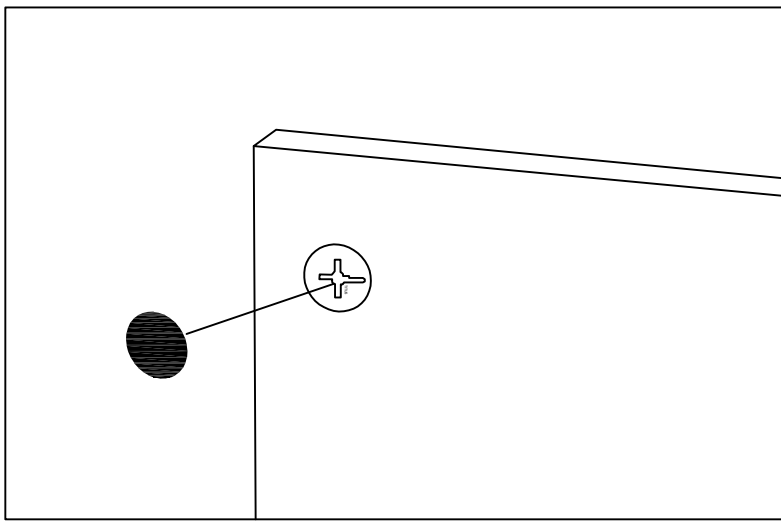

EN: After installing the product, stick the number **○** on the perforated position

FR: Une fois le produit installé, collez le numéro **○** à l'endroit où il y a des trous

DE: Nach der Installation des Produkts kleben Sie die

Nummer **○** auf die perforierte Position

IT: Dopo l'installazione del prodotto, fissare il numero **○** sulla posizione perforata

ES: Después de instalar el producto, pegue el número **○** en la posición perforada

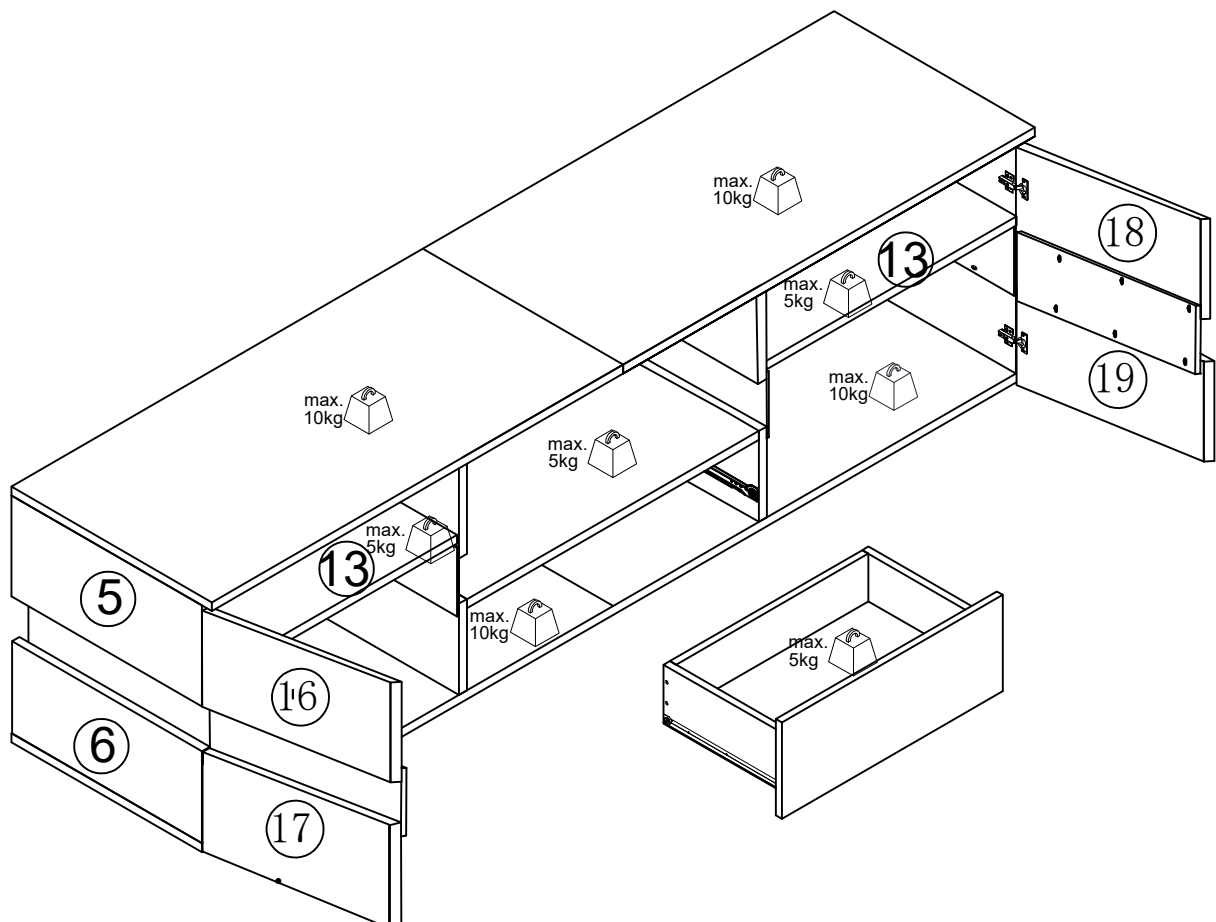

## APP-PROGRAMMANWENDUNG

Klicken, um  
Lampenliste  
anzuzeigen  
Farbrad  
wechseln

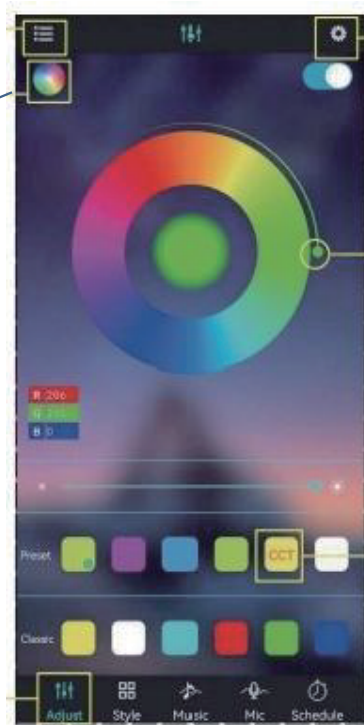

Klicken für  
Einstellungsansicht

Farbe anpassen

Farbanpassung  
per Quadrat-  
Symbol

Schnittstelle  
durch Klicken  
wechseln



## HINWEIS:

Detaillierte Anleitung im  
Menü "Guide"

## PRODUKTPARAMETER

- Bluetooth: BLEVA 2
- Eingangsspannung: 4.5~26V
- Betriebstemperatur: -25~75 °C
- Abmessungen: 43×22×11 mm
- Gewicht: 30g
- Max. Leistung: 144W (24V)

## VERBINDUNGSSCHRITTE

- ① LED-Farbstreifen & Controller verbinden, Controller einschalten
- ② QR-Code scannen zum App-Download:



- ③ App starten, Controller suchen & verbinden
- ④ Bluetooth-Drahtlossteuerung genießen

## PRODUKTMERKMALE

- Direkte Handy-Steuerung (20m Reichweite)
- Automatische Verbindung in 5 Sekunden
- Musikrhythmus-Synchronisation
- Gruppensteuerung
- Helligkeits-/Geschwindigkeitsregelung
- Unterstützt bis 10m RGB(W)-Streifen
- Automatische Sprachumschaltung (DE/EN)

## ANIMATIONSEFFEKTE

- Farbverläufe
- Einfarbige/ Zweifarbige Gradienten
- Monochrome/Bunte Blinkeffekte
- Farbspringen
- Musikresponsive Effekte

## APP PROGRAM USAGE

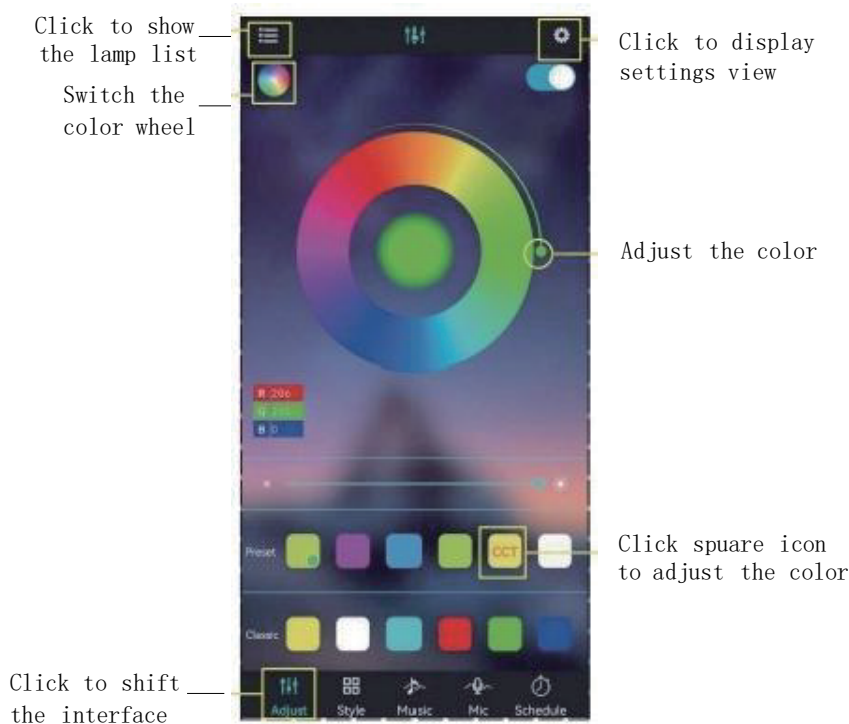

- Scan two-dimensional code download APP
- ①Connect LED color strip and controller, power on controller
  - ②Scan two-dimensional code download APP:



- ③Start APP, search and connect controller
- ④Enjoy the Bluetooth wireless control experience



Notes:  
detailed operating instructions,  
enter the menu "Guide":

Product Paramters:

- Bluetooth:BLEV4.2
- Input Voltage:4.5~26V
- Working Temp:-25~75°C
- Size:43\*22\*11mm
- Weight:30g
- Max Power:144W (24V)

LED mobile phone Bluetooth controllerProduct Features

- LED Bluetooth controller is directly via mobilephone control remote distance can reach 20m without the need to setupeasy to connect open the software within 5 seconds you can automatically connect the controller
- Flow the rhythm of the music changes
- Group control
- Brightness, speed addition and subtraction
- Maximum can be 10 meters RGB(W) strip
- The software shows that the text is based onthe language of the mobile phone set up automatic transformation of Chinese and English

ANIMATION EFFECTS:

- Colorful gradient
- All kinds of monochrome, double color gradient
- All kinds of monochrome, double color, colorfull flashing
- Colorful jump
- Follow the thymhm of the music chagnes

## APP-PROGRAMMANWENDUNG

Afficher la  
liste des lampes  
Farbrad  
Changer la  
Roue chromatique



Afficher les  
paramètres

Ajuster la couleur

Cliquez sur l'icône  
carrée pour ajuster  
la couleur.

Changer d'  
interface  
par clic



### REMARQUE :

Guide détaillé dans le menu  
"Guide"

### CARACTÉRISTIQUES

- Bluetooth : BLEVA 2
- Tension d'entrée : 4.5~26V
- Température : -25~75° C
- Dimensions : 43×22×11 mm
- Poids : 30g
- Puissance max : 144W (24V)

## ÉTAPES DE CONNEXION

- ① Connecter bande LED & contrôleur, allumer
- ② Scanner QR code pour télécharger l'app :



- ③ Lancer l'app, rechercher & connecter
- ④ Profiter du contrôle Bluetooth sans fil

## FONCTIONNALITÉS

- Contrôle direct par smartphone (20m)
- Connexion automatique en 5 secondes
- Synchronisation musicale
- Contrôle de groupe
- Réglage luminosité/vitesse
- Prise en charge bandes ≤10m RGB(W)
- Basculement automatique FR/EN

## EFFETS D'ANIMATION

- Dégradés de couleurs
- Dégradés uni/bicolores
- Clignotements mono/colorés
- Saut de couleurs
- Effets réactifs à la musique

## UTILIZZO APP



## PASSI CONNESSIONE

- ① Collega striscia LED & controller, accendi
- ② Scansiona QR code per scaricare APP:



- ③ Avvia APP, cerca & connetti controller
- ④ Goditi controllo wireless Bluetooth



## NOTA:

Guida completa nel menu "Guide"

## SPECIFICHE:

- Bluetooth: BLEVA 2
- Tensione ingresso: 4.5~26V
- Temperatura: -25~75° C
- Dimensioni: 43×22×11 mm
- Peso: 30g
- Potenza max: 144W (24V)

## CARATTERISTICHE

- Controllo diretto smartphone (20m)
- Connessione automatica in 5 secondi
- Sincronizzazione ritmo musicale
- Controllo di gruppo
- Regolazione luminosità/velocità
- Supporto strisce ≤10m RGB(W)
- Auto switch IT/EN

## EFFETTI ANIMAZIONE:

- Sfumature colore
- Gradienti mono/bicolori
- Luci lampeggianti mono/colorate
- Salto colori
- Effetti reattivi alla musica

## USO DE LA APLICACIÓN

Mostrar lista de —  
Lámparas  
Cambiar rueda de color

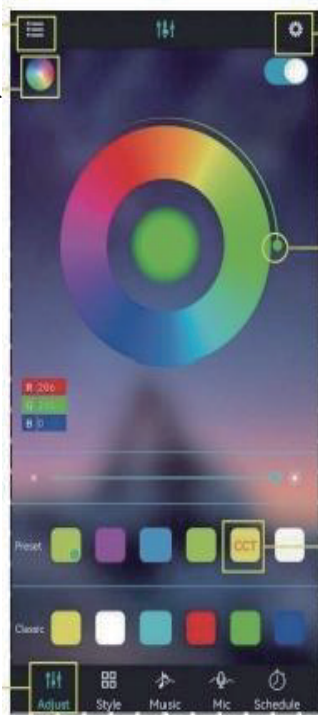

Ver ajustes

Ajustar el color

Clicar para ajustar color  
con icono cuadrado

Cambiar interfaz  
haciendo clic —



NOTA:

Guía completa en menú "Guide"

ESPECIFICACIONES:

- Bluetooth: BLEVA 2
- Voltaje entrada: 4.5~26V
- Temperatura: -25~75° C
- Tamaño: 43×22×11 mm
- Peso: 30g
- Potencia máx: 144W (24V)

## PASOS DE CONEXIÓN

- ① Conectar tira LED y controlador, encender
- ② Escanear QR para descargar APP:



- ③ Iniciar APP, buscar y conectar
- ④ Disfrutar control inalámbrico Bluetooth

## CARACTERÍSTICAS

- Control directo móvil (20m alcance)
- Conexión automática en 5 segundos
- Sincronización ritmo musical
- Control grupal
- Ajuste brillo/velocidad
- Soporte tiras ≤10m RGB(W)
- Auto cambio ES/EN

## EFFECTOS DE ANIMACIÓN:

- Degradados de color
- Transiciones mono/bicolores
- Destellos monocromáticos/color
- Salto de colores
- Efectos reactivos a música



[DE]  
BITTE BEACHTEN: Teilenummer 16 , 17 , 18 , 19 , 20 , 21 ist mit einer dichten Kunststoffschutzfolie überzogen. Wenn das Produkt nach der Demontage Kratzer aufweist, machen Sie sich bitte keine Sorgen, es handelt sich nicht um einen Produktschaden. Bitte ziehen Sie die schützende Kunststofffolie langsam entlang der Kante von der Oberfläche ab. Nach dem Abziehen wird das Produkt glatt und sauber.

[EN]  
PLEASE NOTE: Part number 16 , 17 , 18 , 19 , 20 , 21 are covered with a tight plastic protective film. If there are scratches on the product after disassembly, please don't worry, it's not product damage. Please slowly tear off the protective plastic film on the surface along the edge. After peeling off, the product becomes smooth and clean.

[FR]  
REMARQUE : les pièces numéro 16 , 17 , 18 , 19 , 20 , 21 sont recouvertes d'un film protecteur en plastique étanche. Si le produit présente des rayures après le démontage, ne vous inquiétez pas, il ne s'agit pas d'un dommage au produit.  
Retirez lentement le film protecteur en plastique sur la surface le long du bord. Une fois décollé, le produit devient lisse et propre.

[IT]  
NOTA BENE: il numero di parte 16 , 17 , 18 , 19 , 20 , 21 è coperto da una pellicola protettiva in plastica stretta. Se ci sono graffi sul prodotto dopo lo smontaggio, non preoccuparti, non è un danno al prodotto. Strappare lentamente la pellicola protettiva in plastica sulla superficie lungo il bordo. Dopo averla staccata, il prodotto diventa liscio e pulito.

[ES]  
NOTA: La pieza número 16 , 17 , 18 , 19 , 20 , 21 está cubierta con una película protectora de plástico. Si hay rayones en el producto después de desmontarlo, no se preocupe, no se trata de daños en el producto. Retire lentamente la película protectora de plástico de la superficie a lo largo del borde. Después de despegarla, el producto quedará liso y limpio.

Shenzhen ZKT Technology Co., Ltd.

1/F, No. 101, Building B, No. 6, Tangwei Community Industrial Avenue,  
Fuhai Street, Bao'an District, Shenzhen, China



# Certificate of Compliance

Certificate Number: ZKT-260105L0127C

**Certificate's Holder** : Shenzhen Lanling Optoelectronics Technology Co., Ltd  
 511-G5, Building C, No. 101 Fukang Road, Henggang Community, Henggang Street, Longgang District, Shenzhen City, Guangdong Province  
**Manufacturer** : Shenzhen Lanling Optoelectronics Technology Co., Ltd  
 511-G5, Building C, No. 101 Fukang Road, Henggang Community, Henggang Street, Longgang District, Shenzhen City, Guangdong Province  
**Trade Mark** : /  
**Product** : Controller strip lights  
**Model(s)** : YH-358

| REQUIREMENT       | STANDARD  | Report No.         |
|-------------------|---|--------------------|
| Art.3.1(a) Safety | EN 60598-2-21:2015<br>EN IEC 60598-1:2024+A11:2024<br>EN IEC 62031:2020+A11:2021  | ZKT-260105L0128S   |
| Art.3.1(a) Health | EN 62479:2010<br>EN 50663:2017  | ZKT-260105L0127E-3 |
| Art.3.1(b) EMC    | ETSI EN 301 489-1 V2.2.3 (2019-11)<br>ETSI EN 301 489-17 V3.3.1 (2024-09)<br>EN IEC 61000-3-2:2019 + A1:2021 + A2:2024<br>EN 61000-3-3:2013 + A1:2019 + A2:2021 | ZKT-260105L0127E-1 |
| Art.3.2 Radio     | ETSI EN 300 328 V2.2.2 (2019-07)  | ZKT-260105L0127E-2 |

This Attestation of Compliance is issued on for electrical equipment below the voltage limits of Radio Equipment Directive (RED) 2014/53/EU. The essential requirement are fulfilled accordingly based on the technical specifications applicable at the time of issuance.



This Certificate of Conformity is based on single evaluation of the submitted sample(s) of the above mentioned product. It does not imply an assessment of the whole product and relevant . Directives to be observed.

Shenzhen ZKT Technology Co., Ltd.

1/F, No. 101, Building B, No. 6, Tangwei Community Industrial Avenue,  
Fuhai Street, Bao'an District, Shenzhen, China



# Certificate of Compliance

Certificate Number: ZKT-260114L0992C

**Certificate's Holder** : Shenzhen Lanling Optoelectronics Technology Co., Ltd  
**Address** : 511-G5, Building C, No. 101 Fukang Road, Henggang Community, Henggang Street, Longgang District, Shenzhen City, Guangdong Province

**Manufacturer** : Shenzhen Lanling Optoelectronics Technology Co., Ltd  
**Address** : 511-G5, Building C, No. 101 Fukang Road, Henggang Community, Henggang Street, Longgang District, Shenzhen City, Guangdong Province

**Product** : Controller strip lights  
**Trade Mark** : /  
**Model(s)** : YH-358  
 LL-LED5050X60, LL-LED5050X18, LL-LED5050X30,  
 LL-LED5050X48, LL-LED5050X60, LL-LED5050X72,  
 LL-LED5050X90, LL-LED5050X120, LL-LED2835X30,  
 LL-LED2835X60, LL-LED2835X120, LL-LED2835X180,  
 LL-LED2835X240, LL-LED3528X30, LL-LED3528X60,  
 LL-LED3528X120, LL-LED3528X240, LL-LED5730X60,  
 LL-LED5730X72, LL-LED5730X84, LL-LED3535X60,  
 LL-LED3535X120, CWG-5050RGB-60D-5v

**Test Method** : IEC 62321-5:2013 & IEC 62321-4:2013+A1:2017 &  
 IEC 62321-7-2:2017 & IEC 62321-6:2015 & IEC 62321-8:2017  
 & IEC 62321-3-1:2013 & IEC 62321-7-1:2015

The following products have been tested by us and found in conformity with the (RoHS) Directive 2011/65/EU Annex II amending Annex (EU)2015/863 and amending Annex (EU)2017/2102. It is possible to use CE Marking to demonstrate the conformity with this Directive. It is only valid in connection with the test report number: ZKT-260114L0992R. After preparation of the necessary technical documentation according the requirement of EN IEC 63000:2018 as well as the verification of conformity the CE marking as shown below can be affixed on the equipment.

# RoHS



This Certificate of Conformity is based on single evaluation of the submitted sample(s) of the above mentioned product. It does not imply an assessment of the whole product and relevant Directives to be observed.