

N625P333723W/N625P333724W  
N605P417253W/N605P417254W

Product manual  
Gebrauchsanweisung  
Manuel du produit  
Manual del producto  
Manuale del prodotto

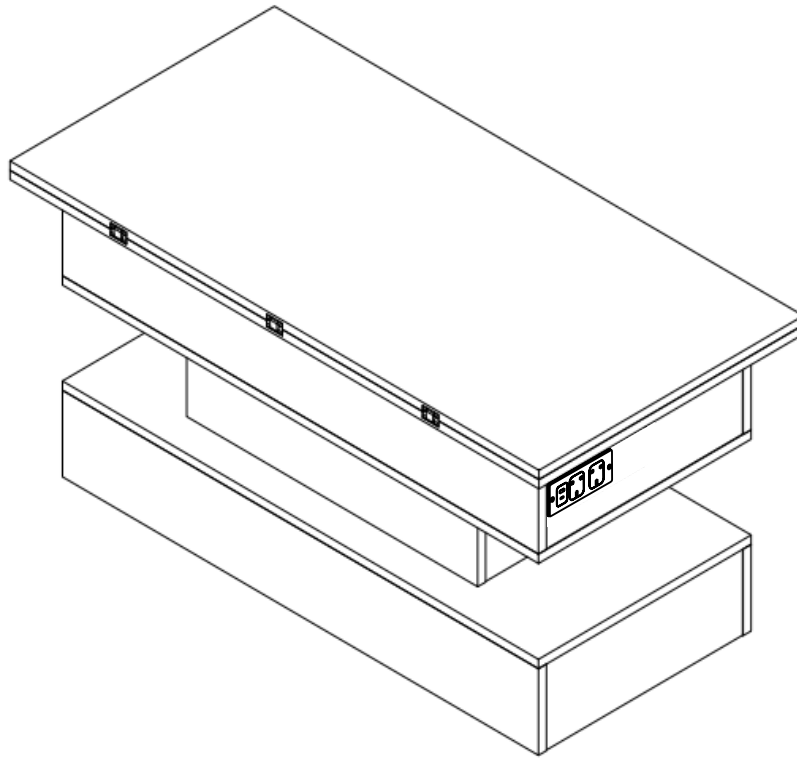

EN:Our product will be delivered to you in 2 packages.The delivery times of these 2 packages may differ, please be patient and thank you for your understanding

FR:Notre produit vous sera livré en 2 colis.Les délais de livraison de ces 2 colis peuvent différer,

soyez patient et merci de votre compréhension.

DE:Unser Produkt wird Ihnen in 2 Paketen geliefert.Die Lieferzeiten dieser 2

Paketekönnenabweichen,bitte haben Sie etwas Geduld und vielen Dank für Ihr Verständnis

IT:I nostri prodotti vengono trasportati in due pacchetti. I tempi di consegna dei due pacchetti sono diversi abbiate pazienza e vi ringrazio per la vostra comprensione.

ES:Nuestro producto se entrega en dos paquetes. El tiempo de entrega de estos dos paquetes es

diferente. Por favor sea paciente. Gracias por su comprensión.

UK  
CA



CE

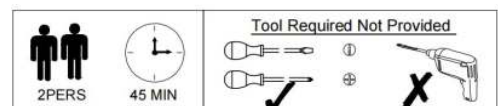



[DE]

Warnung: Lesen Sie diese Anleitung vor dem Zusammenbau bitte vollständig durch. Überprüfen Sie, ob Sie alle auf den Seiten aufgeführten Komponenten und Werkzeuge haben. Bewahren Sie die Anleitung zum späteren Nachschlagen auf. Teile des Zusammenbaus lassen sich mit 2 Personen leichter durchführen. Suchen Sie bei Bedarf professionelle Hilfe.

Warnung: Legen Sie alle Teile auf eine ebene Fläche. Legen Sie eine weiche Decke oder Ähnliches darunter, um sie vor Kratzern oder Flecken zu schützen. Vermeiden Sie es, Komponenten über den Boden zu ziehen oder zu schieben.

Warnung: Überprüfen Sie regelmäßig alle Beschläge und Befestigungen, um sicherzustellen, dass sie sicher sind und um Unfälle zu vermeiden. Wenn Teile fehlen, kaputt, beschädigt oder abgenutzt sind, verwenden Sie das Produkt nicht weiter, bis es mit vom Hersteller autorisierten Teilen repariert wurde.

Warnung: Lassen Sie Kinder nicht auf die Möbel klettern, da dies zum Umkippen und zu schweren Verletzungen führen kann. Bauen Sie die Möbel außerhalb der Reichweite von Kindern zusammen.

Warnung: Stellen Sie die Möbel nicht in die Nähe von Feuerquellen oder heißen Gegenständen, um Brandgefahr zu vermeiden.

Warnung: Reinigen Sie die Möbel mit einem feuchten Tuch oder Alkohol. Verwenden Sie keine Reinigungsmittel mit ätzenden Chemikalien.

[EN]

Warning: Please read these instructions fully before starting assembly. Check you have all the components and tools listed on pages. Keep the instructions for later reference. Parts of the assembly will be easier with 2 people. Seek professional assistance if necessary.

Warning: Please place all parts on a flat surface. Place a soft blanket or similar underneath to protect against scratches or stains. Avoid dragging or sliding components across the floor.

Warning: Regularly check all fittings and fastenings to ensure they are secure and to prevent accidents. If any parts are missing, broken, damaged, or worn, discontinue use of the product until repairs have been made using factory authorized parts.

Warning: Do not allow children to climb on the furniture as this may result in tipping and serious personal injury. Assemble the furniture away from the reach of children.

Warning: Do not place furniture close to fire sources or high-temperature objects to avoid the risk of fire. Do not place furniture in damp environments to prevent material damage.

Warning: Clean furniture with a damp cloth or alcohol, avoid using cleaning agents containing corrosive chemicals.

[FR]

Avertissement : Veuillez lire attentivement ces instructions avant de commencer l'assemblage. Vérifiez que vous disposez de tous les composants et outils répertoriés sur les pages. Conservez les instructions pour référence ultérieure. Certaines parties de l'assemblage seront plus faciles à 2 personnes. Demandez l'aide d'un professionnel si nécessaire.

Avertissement : Veuillez placer toutes les pièces sur une surface plane. Placez une couverture douce ou similaire en dessous pour les protéger des rayures ou des taches. Évitez de faire glisser les composants sur le sol.

Avertissement : Vérifiez régulièrement tous les raccords et fixations pour vous assurer qu'ils sont bien fixés et pour éviter les accidents. Si des pièces manquent, sont cassées, endommagées ou usées, cessez d'utiliser le produit jusqu'à ce que des réparations aient été effectuées à l'aide de pièces autorisées par l'usine.

Avertissement : Ne laissez pas les enfants grimper sur les meubles car cela pourrait entraîner un basculement et des blessures graves. Assemblez les meubles hors de portée des enfants.

Avertissement : Ne placez pas les meubles à proximité de sources de feu ou d'objets à haute température pour éviter tout risque d'incendie.

Avertissement : Nettoyez les meubles avec un chiffon humide ou de l'alcool, évitez d'utiliser des produits de nettoyage contenant des produits chimiques corrosifs.

[IT]

Attenzione: leggere attentamente queste istruzioni prima di iniziare il montaggio. Verificare di avere tutti i componenti e gli strumenti elencati nelle pagine. Conservare le istruzioni per riferimento futuro. Alcune parti del montaggio saranno più facili con 2 persone. Se necessario, chiedere assistenza professionale.

Attenzione: posizionare tutte le parti su una superficie piana. Posizionare una coperta morbida o simile sotto per proteggere da graffi o macchie. Evitare di trascinare o far scivolare i componenti sul pavimento.

Attenzione: controllare regolarmente tutti i raccordi e i dispositivi di fissaggio per assicurarsi che siano sicuri e per prevenire incidenti. Se alcune parti sono mancanti, rotte, danneggiate o usurate, interrompere l'uso del prodotto fino a quando non siano state eseguite le riparazioni utilizzando parti autorizzate dalla fabbrica.

Attenzione: non consentire ai bambini di arrampicarsi sui mobili poiché ciò potrebbe causare ribaltamenti e gravi lesioni personali. Montare i mobili lontano dalla portata dei bambini.

Attenzione: non posizionare i mobili vicino a fonti di fuoco o oggetti ad alta temperatura per evitare il rischio di incendio

Attenzione: pulire i mobili con un panno umido o alcol, evitare di utilizzare detergenti contenenti sostanze chimiche corrosive.

[ES]

Advertencia: Lea estas instrucciones completamente antes de comenzar el montaje. Compruebe que tiene todos los componentes y herramientas que se enumeran en las páginas. Conserve las instrucciones para consultarlas más adelante. El montaje de algunas partes será más sencillo con 2 personas. Busque ayuda profesional si es necesario.

Advertencia: Coloque todas las piezas sobre una superficie plana. Coloque una manta suave o algo similar debajo para protegerlas de rayones o manchas. Evite arrastrar o deslizar los componentes por el piso.

Advertencia: Verifique regularmente todos los accesorios y fijaciones para asegurarse de que estén seguros y evitar accidentes. Si falta alguna pieza, está rota, dañada o desgastada, deje de usar el producto hasta que se hayan realizado las reparaciones con piezas autorizadas de fábrica.

Advertencia: No permita que los niños se suban a los muebles, ya que esto puede provocar que se vuelquen y lesiones personales graves. Monte los muebles fuera del alcance de los niños.

Advertencia: No coloque los muebles cerca de fuentes de fuego u objetos de alta temperatura para evitar el riesgo de incendio.

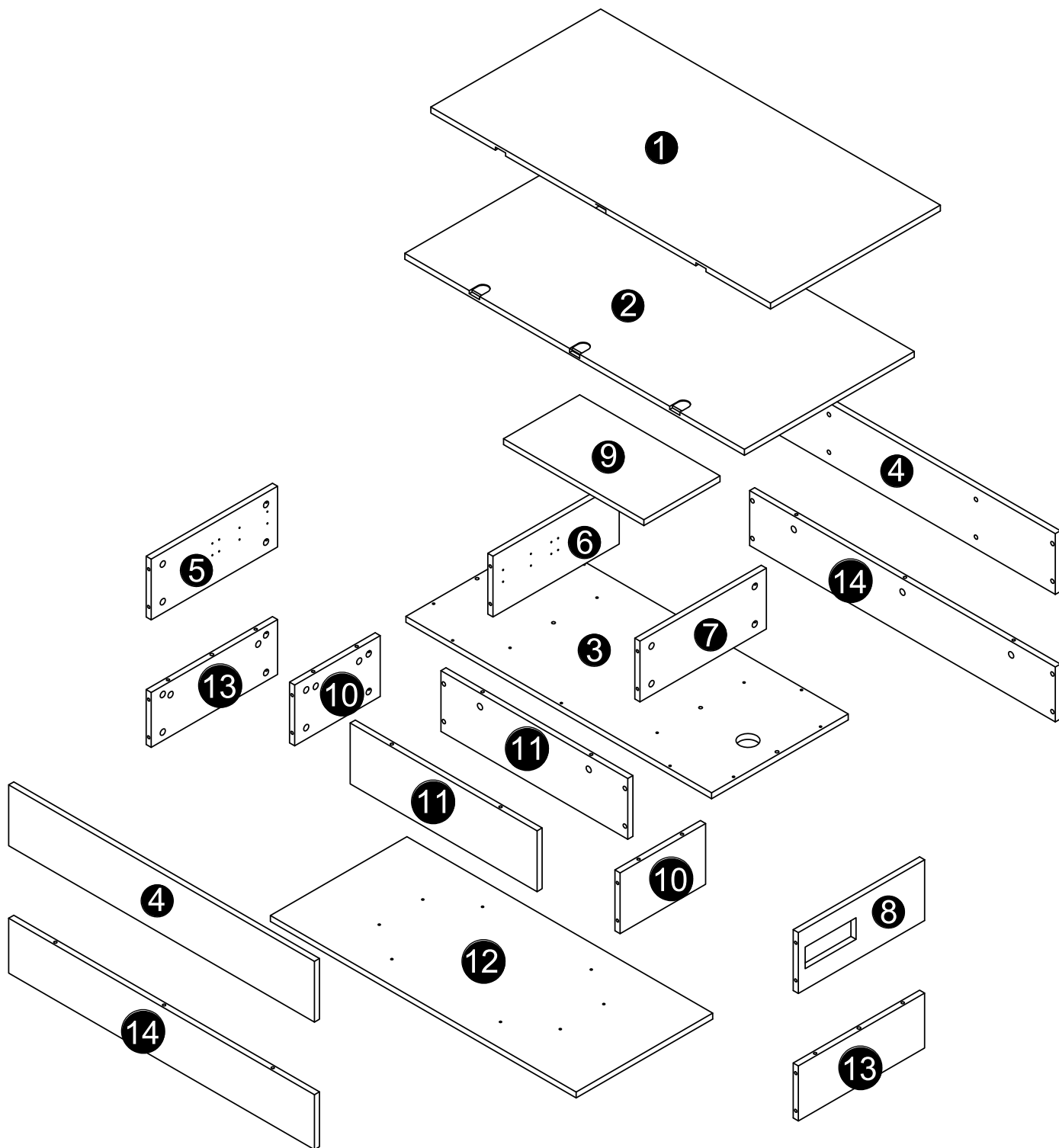

Advertencia: Limpie los muebles con un paño húmedo o alcohol, evite usar agentes de limpieza que contengan químicos corrosivos.



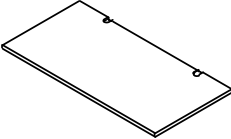
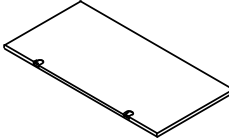
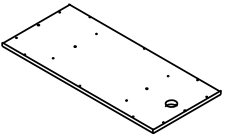



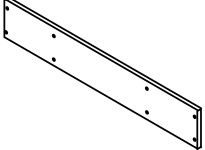
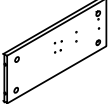
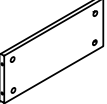
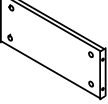
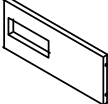
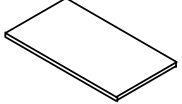

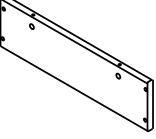
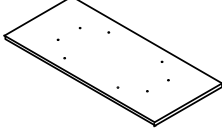
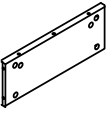
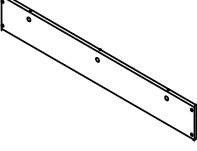

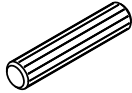
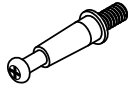

DE:Teilleiste für / EN:Parts List for / FR:Liste des pièces pour / IT:Elenco delle parti per /ES:Lista de piezas para  
 N625P333723W/N605P417253W

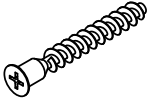
					
① x1	② x1	③ x1			

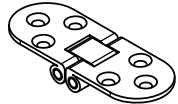
DE:Teilleiste für / EN:Parts List for / FR:Liste des pièces pour / IT:Elenco delle parti per /ES:Lista de piezas para  
 N625P333724W/N605P417254W

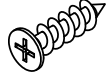
					
④ x2	⑤ x1	⑥ x1	⑦ x1	⑧ x1	⑨ x1
					
⑩ x2	⑪ x2	⑫ x1	⑬ x2	⑭ x2	

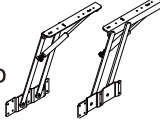
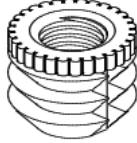
DE:Hardwareliste für / EN:Hardware List for / FR:Liste du matériel pour / IT:Elenco hardware per / ES:Lista de hardware para  
N625P333724W/N605P417254W

<p><b>A</b> x6</p>  <p>8*40</p>	<p><b>B</b> x50</p> 	<p><b>C</b> x50</p> 	<p><b>D</b> x22</p>  <p>5*40</p>	<p><b>E</b> x18</p>  <p>3.5*12</p>	<p><b>F</b> x3</p> 
<p><b>G</b> x1</p> 	<p><b>H</b> x50</p>  <p>3.5*14</p>	<p><b>I</b> x1</p>  <p>2400mm</p>	<p><b>J</b> x50</p> 	<p><b>K</b> x2</p> <p>Left Side Linke Seite Côté Gauche Lado Izquierdo Lato Sinistro</p> 	<p>Right Side Rechte Seite Côté Droit Lado Derecho Lato Destro</p>
<p><b>L</b> x5</p> 	<p><b>M</b> x1</p> 				

EN:If you find that the white glue particles on the board are missing, please press part L into the board.

DE:Sollten Sie feststellen, dass die weißen Gummipartikel auf der Platine fehlen, drücken Sie bitte Teil L indie Platine.

FR:Si vous constatez qu'il manque des particules de caoutchouc blanc sur le tableau, veuillez enfoncer lapartie L dans le tableau.

IT:Se trovi che mancano le particelle di gomma bianca sulla tavola, premi la parte L sulla tavola. ES: Si descubre que faltan las partículas de goma blancas en el tablero, presione la parte L en el tablero.

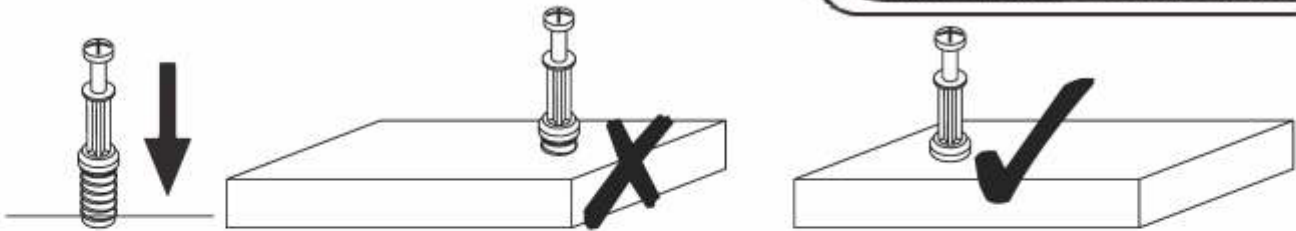

**EN\_QUICKFIT:** Tighten quickfit until shoulder is flush with panel. Do not overtighten or undertighten.

**FR\_RACCORD RAPIDE:** Faites serrer le raccord rapide jusqu'à ce que l'épaulement soit parfaitement encastré dans le panneau. Il ne faut ni trop serrer ni insuffisamment serrer.

**ES\_QUICKFIT:** Apriete quickfit hasta que el hombro se descargue con el panel. NO lo sobreapriete ni lo apriete poco.

**DE\_QUICKFIT:** Ziehen Sie den Quickfit fest, bis die Schulter mit der Platte bündig ist. Bitte nicht zu fest oder zu schwach anziehen.

**IT\_MONTAGGIO RAPIDO:** Stringere il montaggio rapido fino a quando la spalla è a filo con il pannello, non stringere troppo o troppo poco.



**EN\_CAM LOCK:** When fitting cam lock, ensure starting position is correct before you insert connecting quickfit.

**FR\_SERRURE BATTEUSE:** Avant d'insérer la serrure batteuse, veillez à la bonne orientation avant d'insérer le raccord rapide.

**ES\_CIERRE DE LA CÁMARA:** Cuando instale el cierre de la cámara, asegúrese de que la posición de inicio es correcta antes de que inserte el quickfit conector.

**DE\_CAM-LOCK:** Achten Sie bei der Montage des Cam-Locks auf die richtige Ausgangsposition, bevor Sie den Quickfit einsetzen.

**IT\_BLOCCAGGIO A CAMMA:** Quando si monta il bloccaggio a camma, assicurarsi che la posizione iniziale sia corretta prima di inserire il montaggio rapido di collegamento.

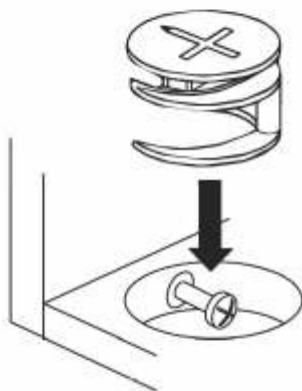

**EN\_Quickfit head** should be in the centre of the cam lock when the two panels are joined.

Cam lock should be inserted before quickfit.

**FR\_**Lorsque les deux panneaux sont assemblés, la tête du raccord rapide doit reposer au centre de la serrure batteuse. Il faut insérer la serrure batteuse avant le raccord rapide.

**ES\_**El cabezal del quickfit debe estar en el centro del cierre de la cámara cuando se unan los dos paneles.

Se debe insertar el cierre de la cámara antes que el quickfit.

**DE\_**Der Quickfit-Kopf sollte sich in der Mitte des Cam-Locks befinden, wenn die beiden Platten zusammengefügt sind.

Der Cam-Lock sollte vor dem Quickfit eingesetzt werden.

**IT\_**La testa del montaggio rapido deve trovarsi al centro del bloccaggio a camma quando i due pannelli sono uniti.

Il Bloccaggio a Camma deve essere inserito prima del montaggio rapido.

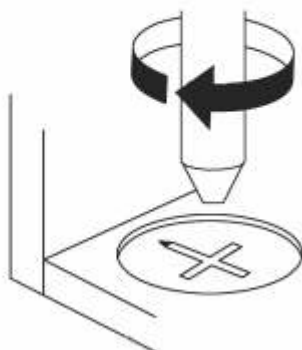

**EN\_**Turn cam lock clockwise to tighten.

**FR\_**Faites tourner la serrure batteuse dans le sens des aiguilles d'une montre pour la resserrer.

**ES\_**Gire el cierre de la cámara en sentido horario para apretarlo.

**DE\_**Drehen Sie den Cam-Lock im Uhrzeigersinn, um ihn festzuziehen.

**IT\_**Ruotare il bloccaggio a camma in senso orario per stringere.

01

Ax4

Bx16



8\*40

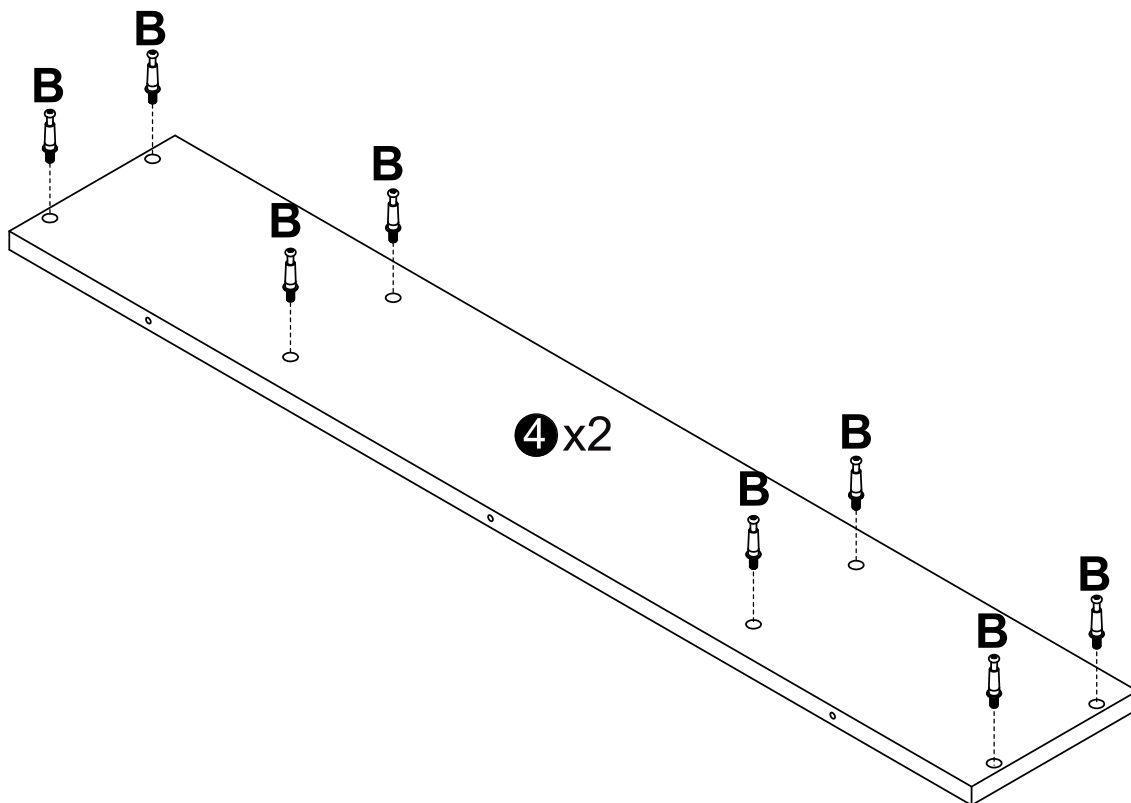
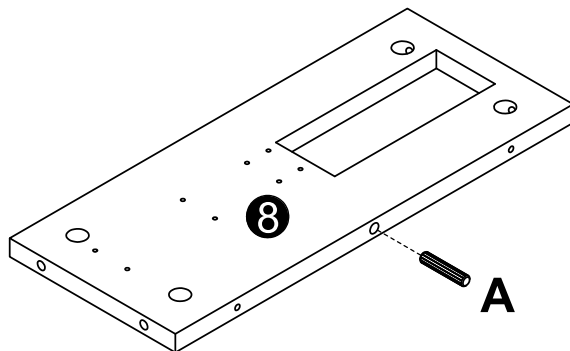
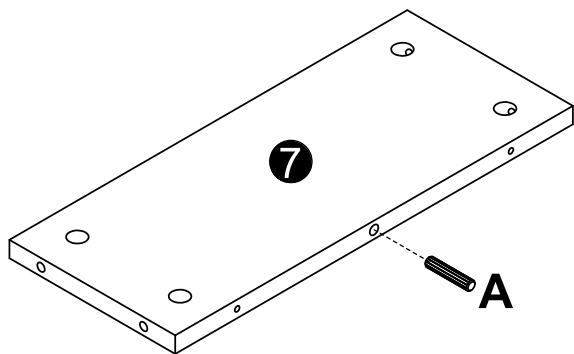
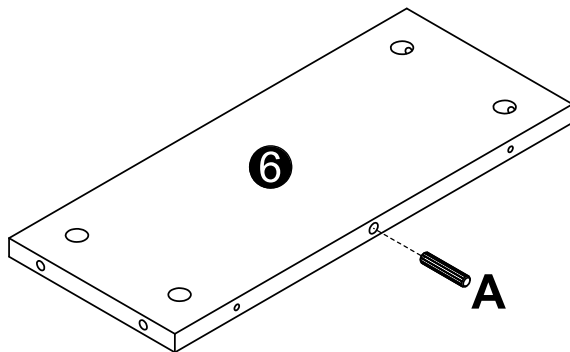
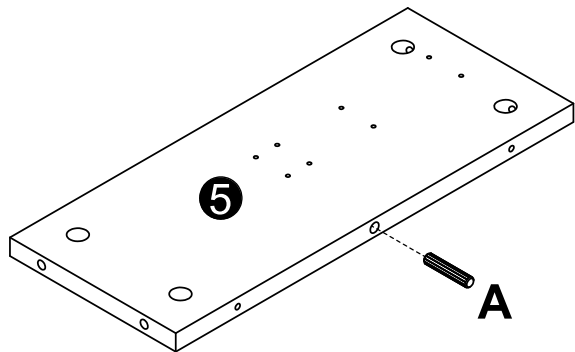

02

Cx16

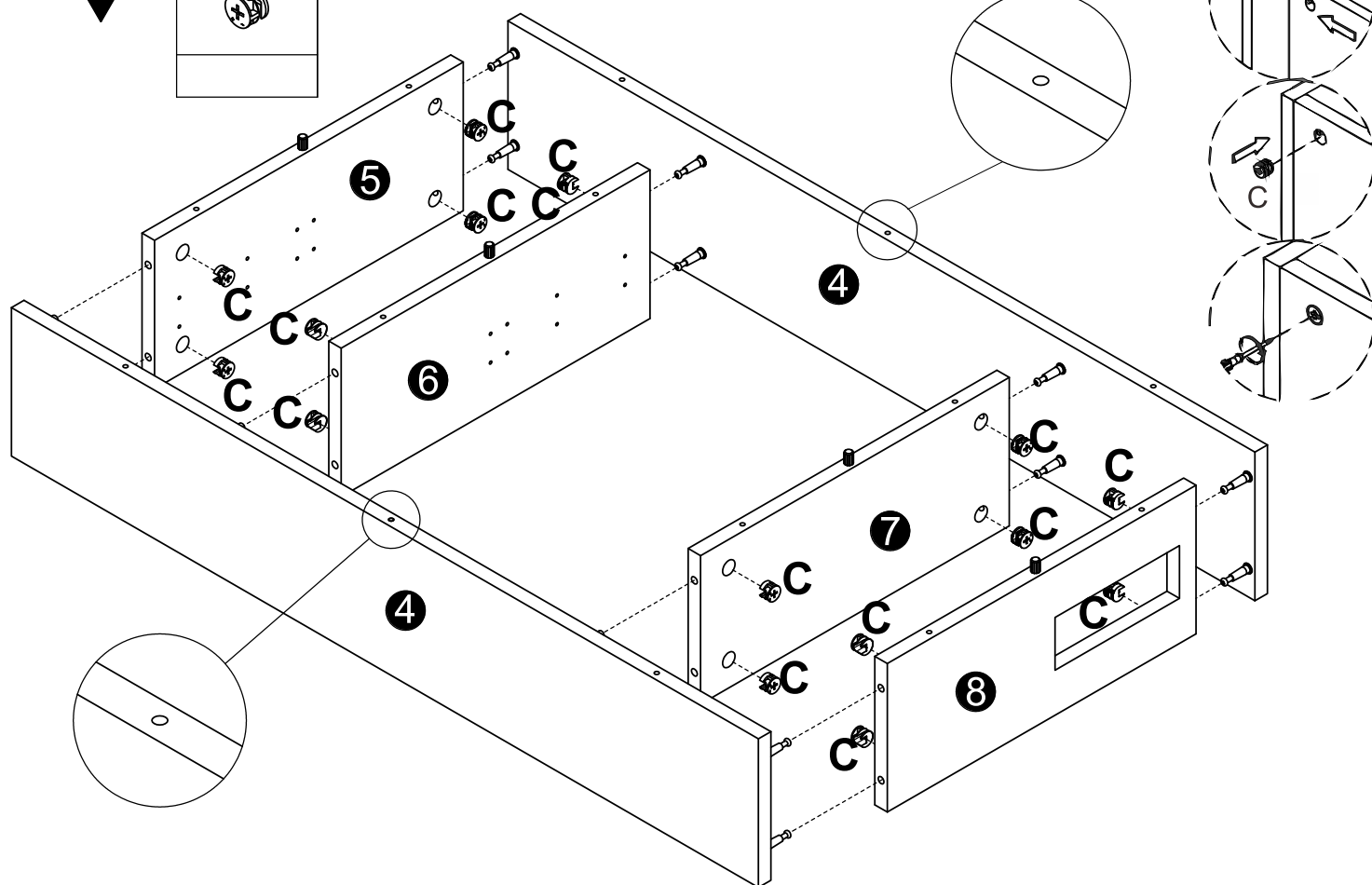

03

Dx14

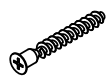

5\*40

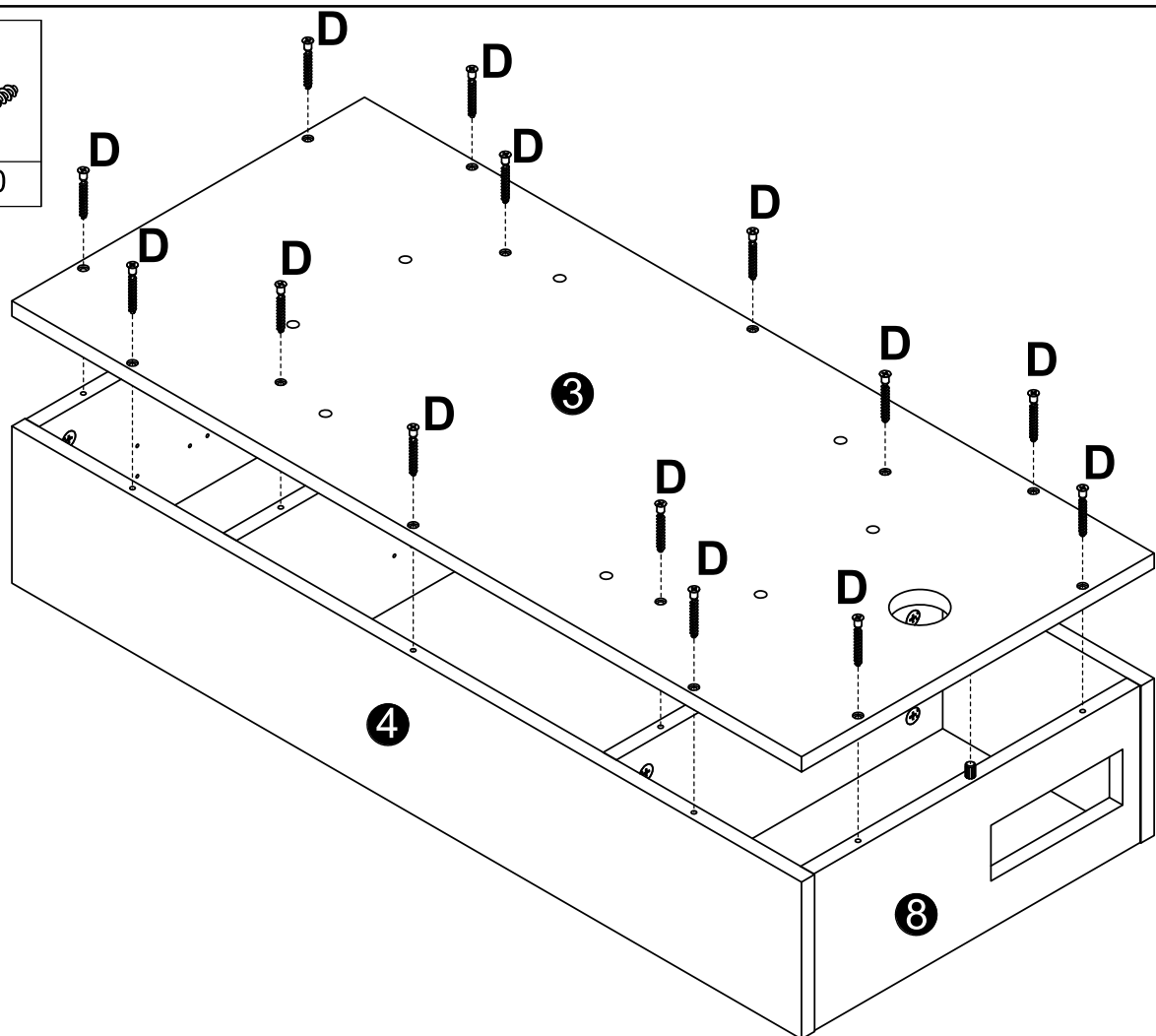

04

Bx8

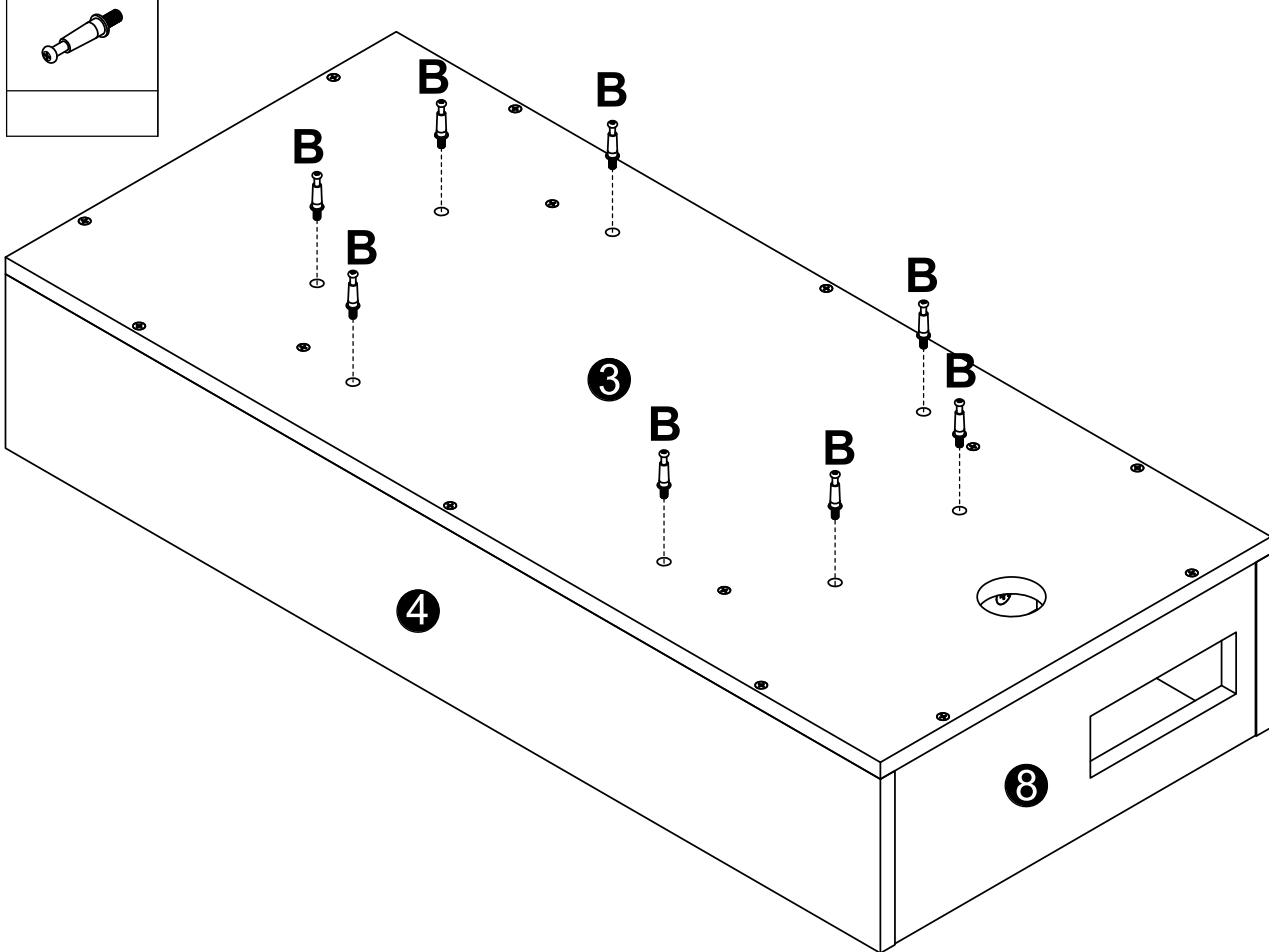

05

Bx8

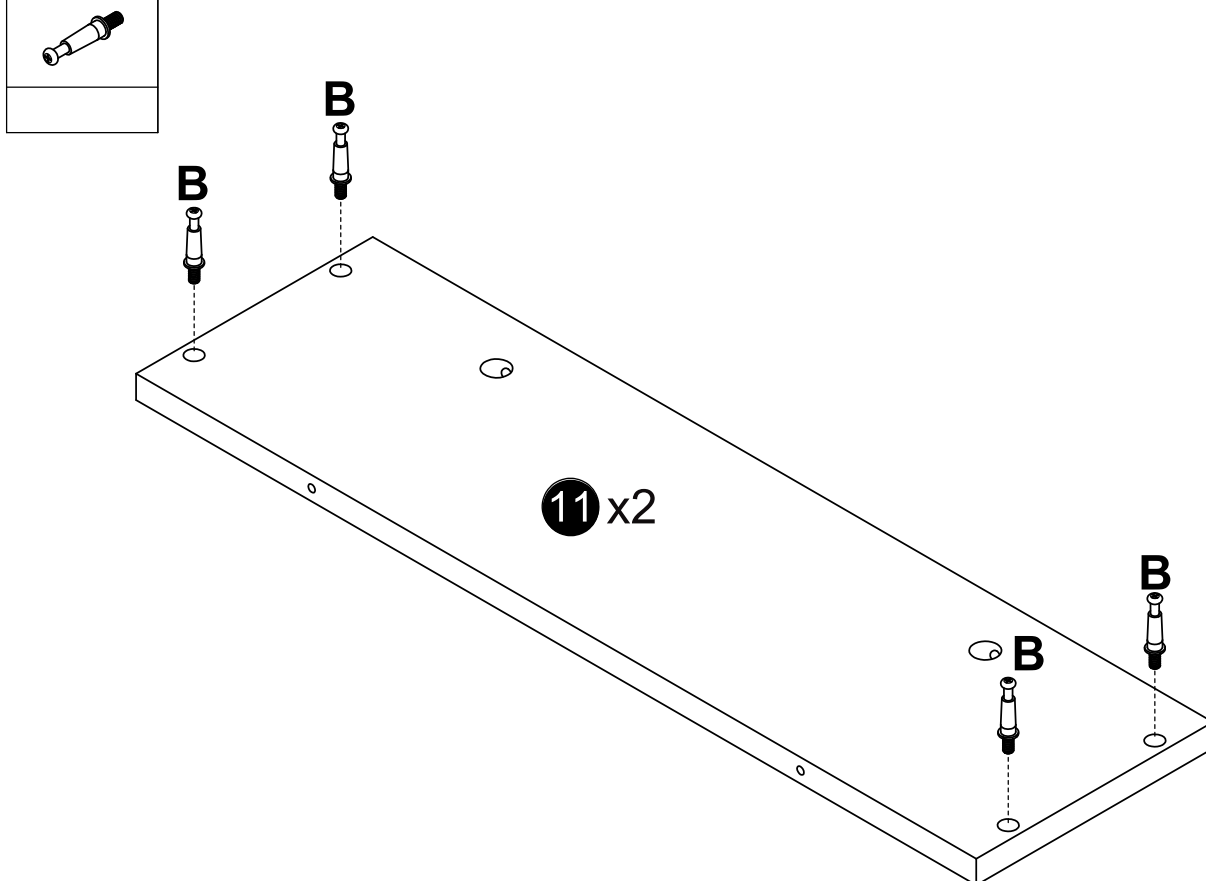

06

Cx8

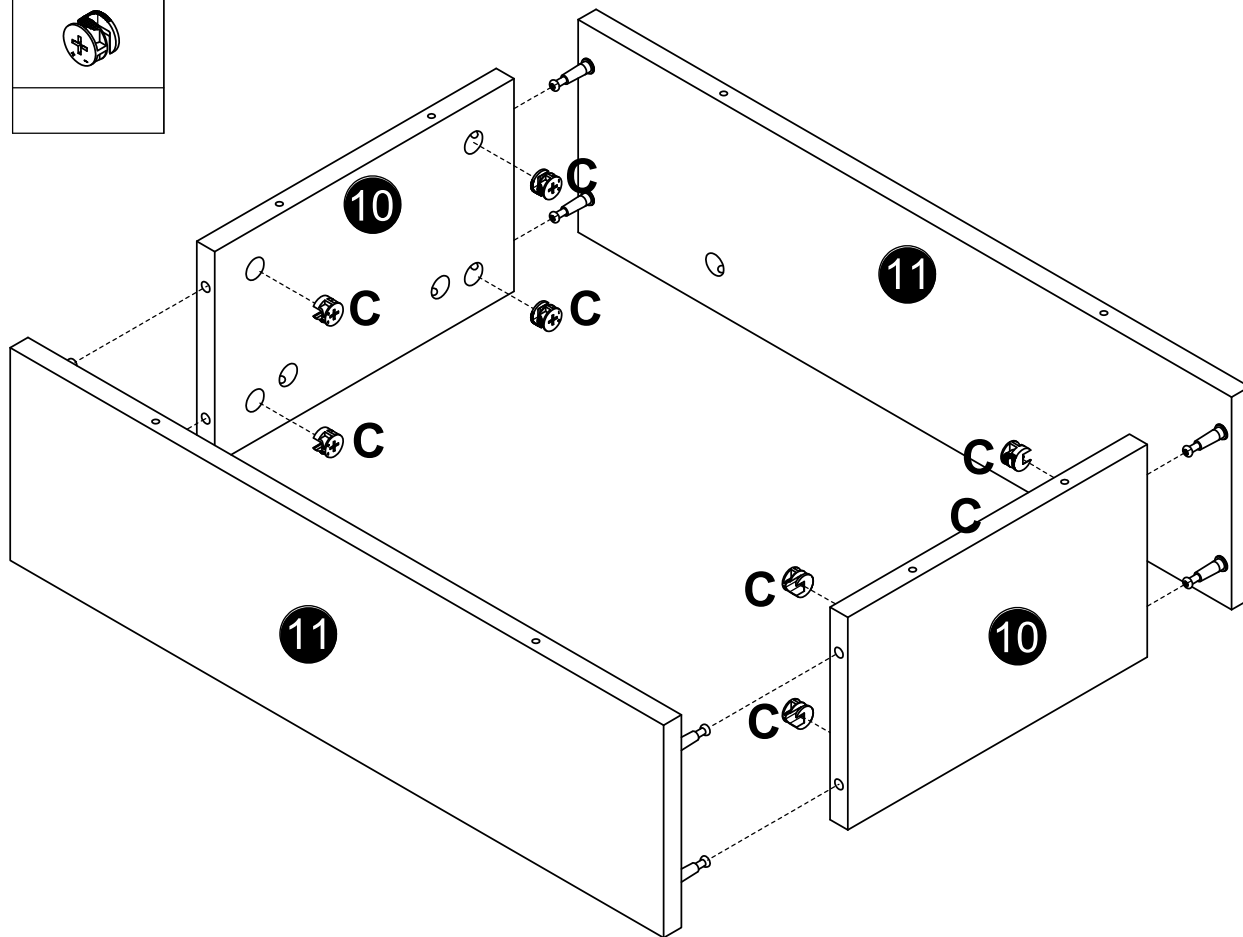

07

Cx8

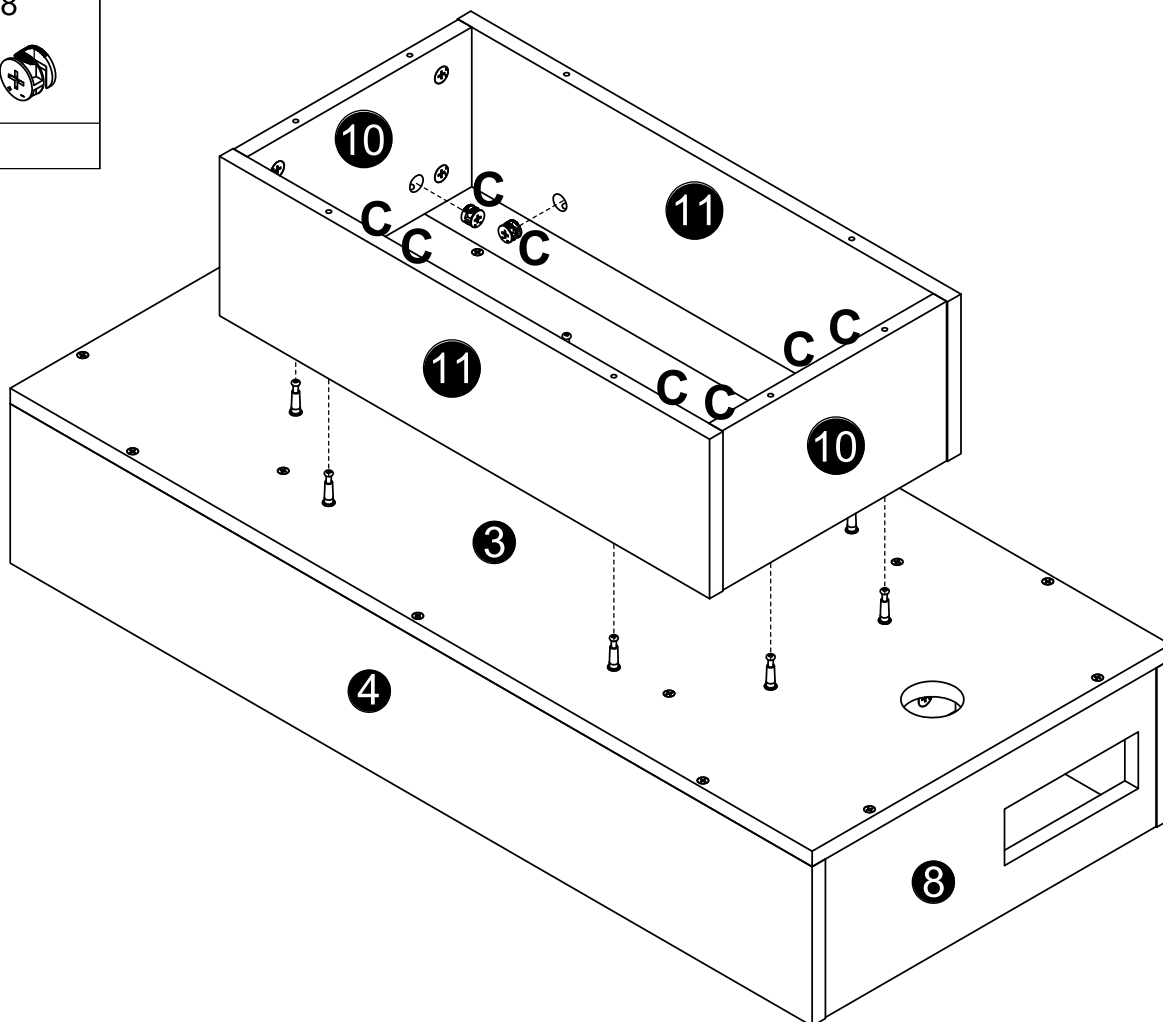

08

Dx8

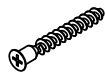

5\*40

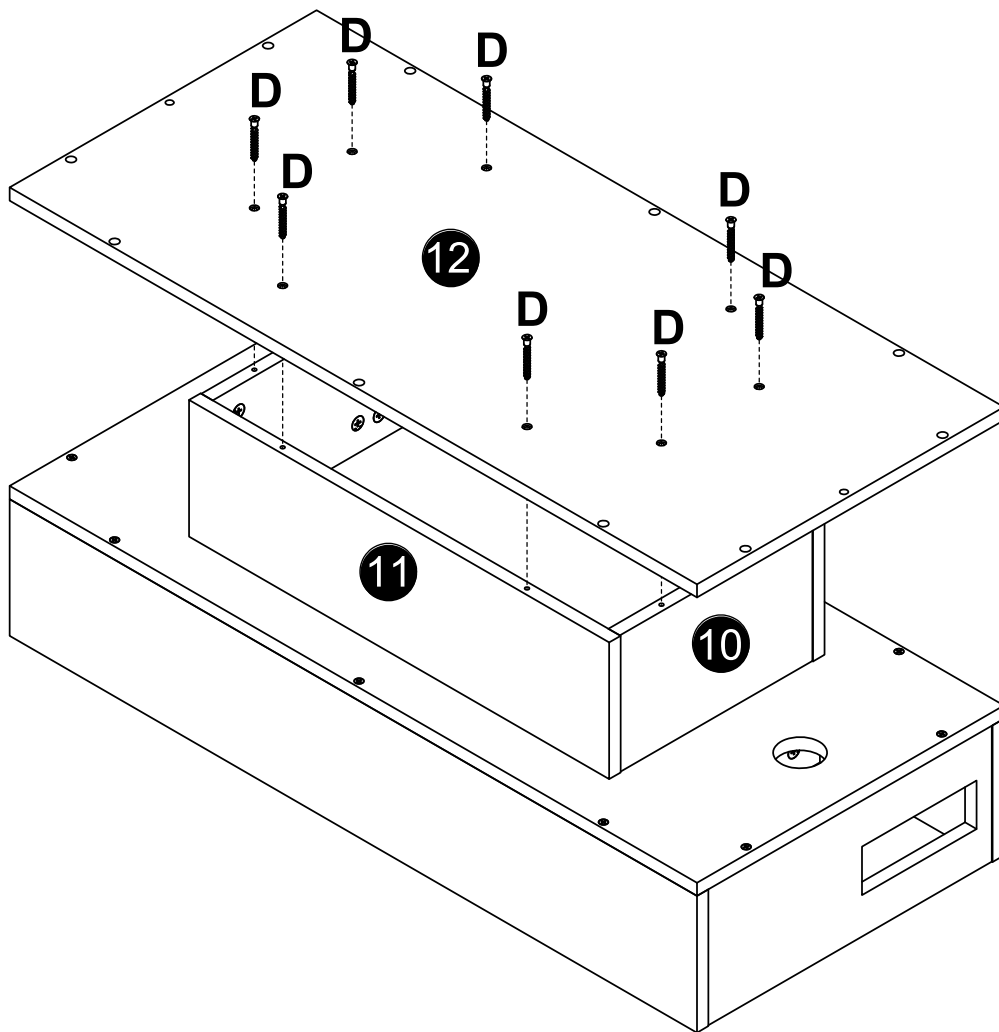

09

Bx10

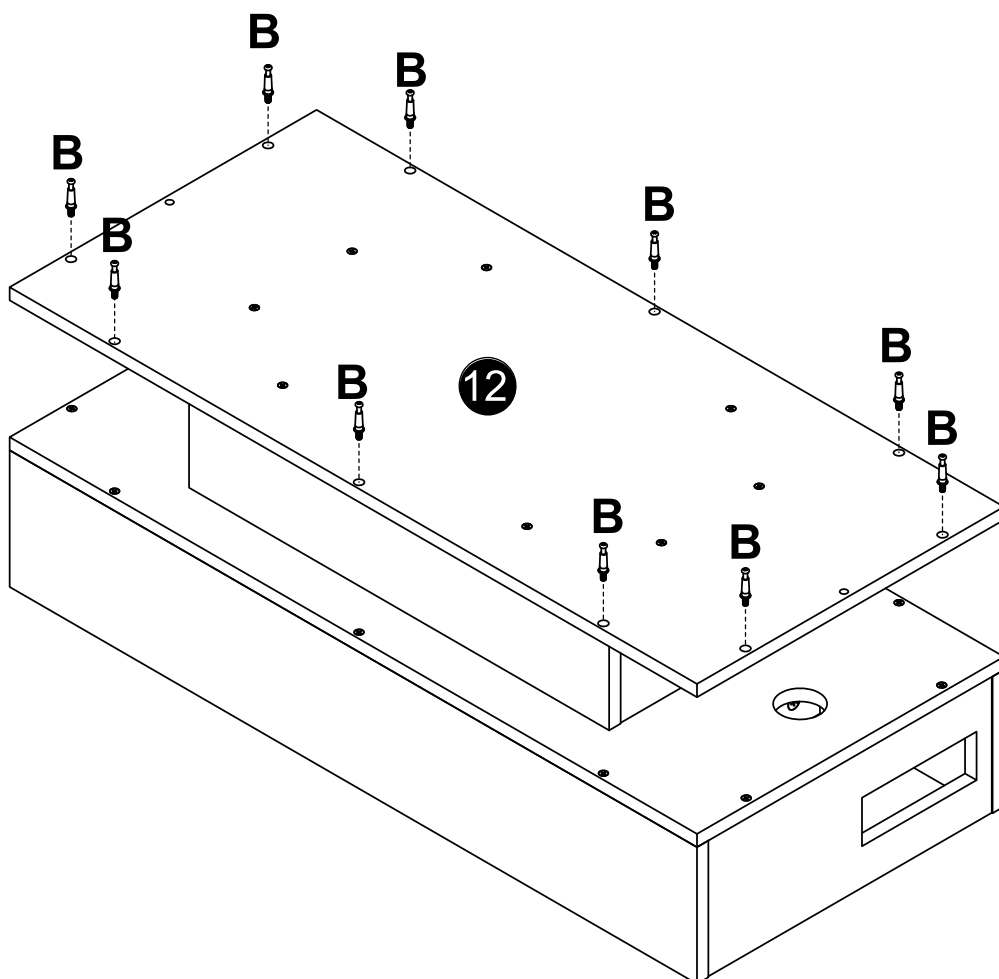

**10**

Ax2



8\*40

Bx8

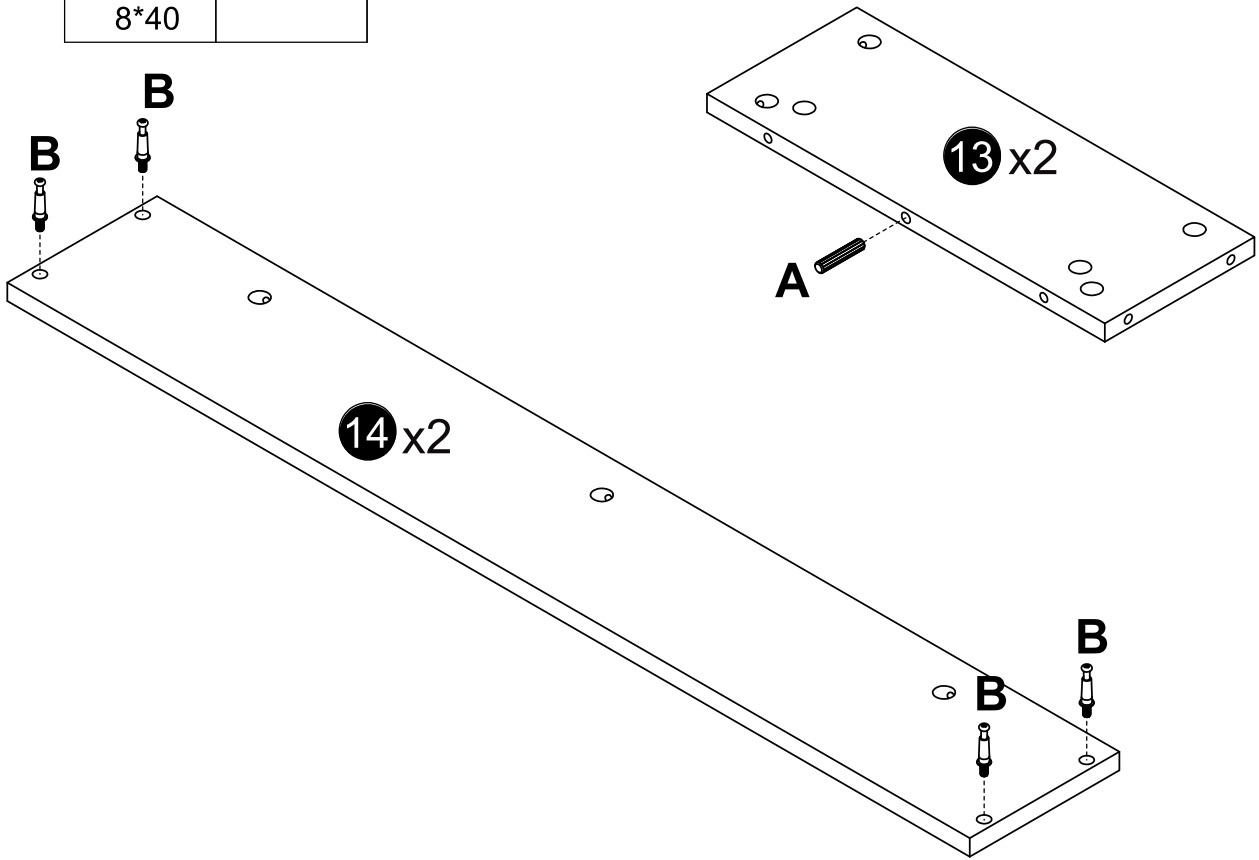
**11**

Cx8

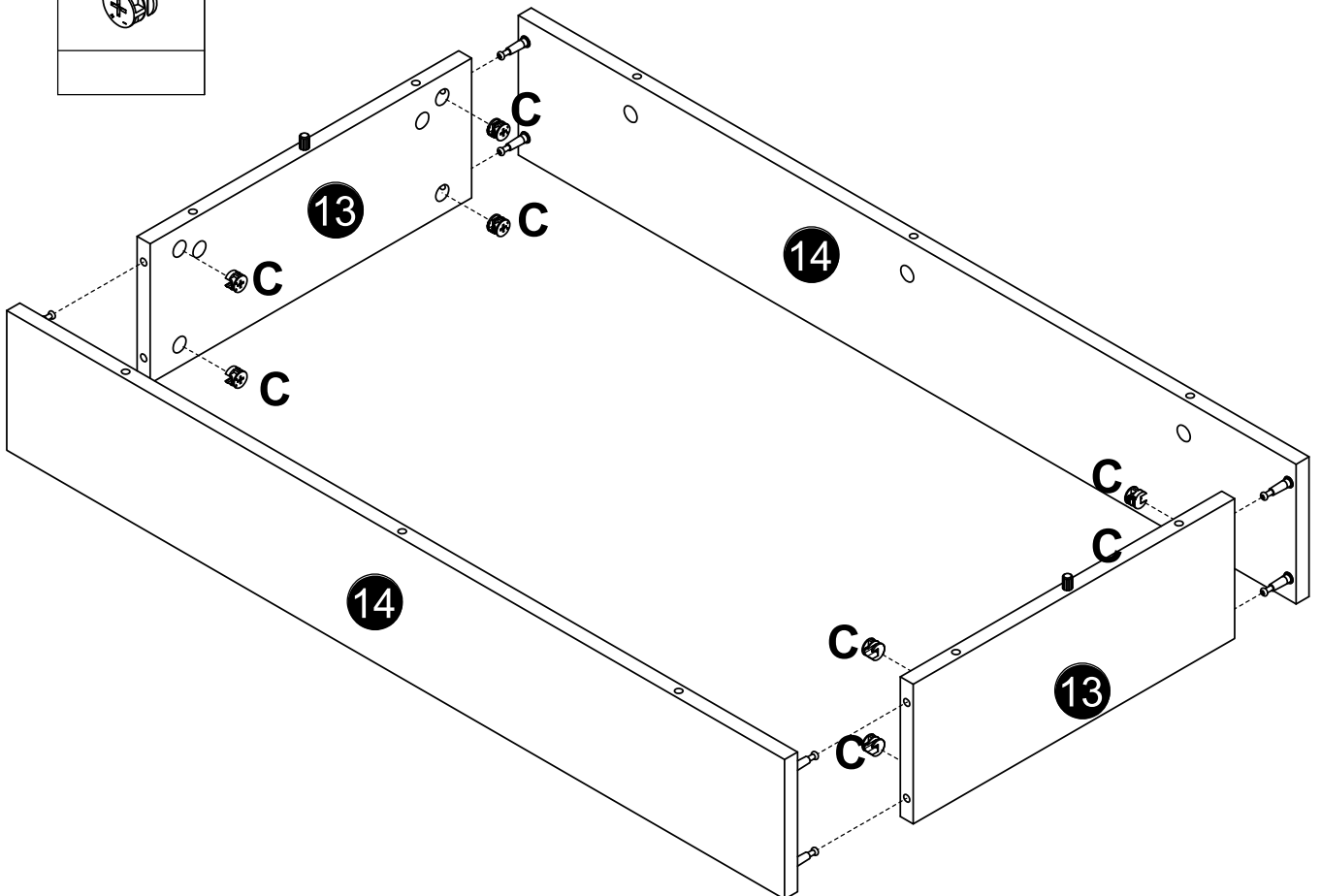

**12**

Cx10

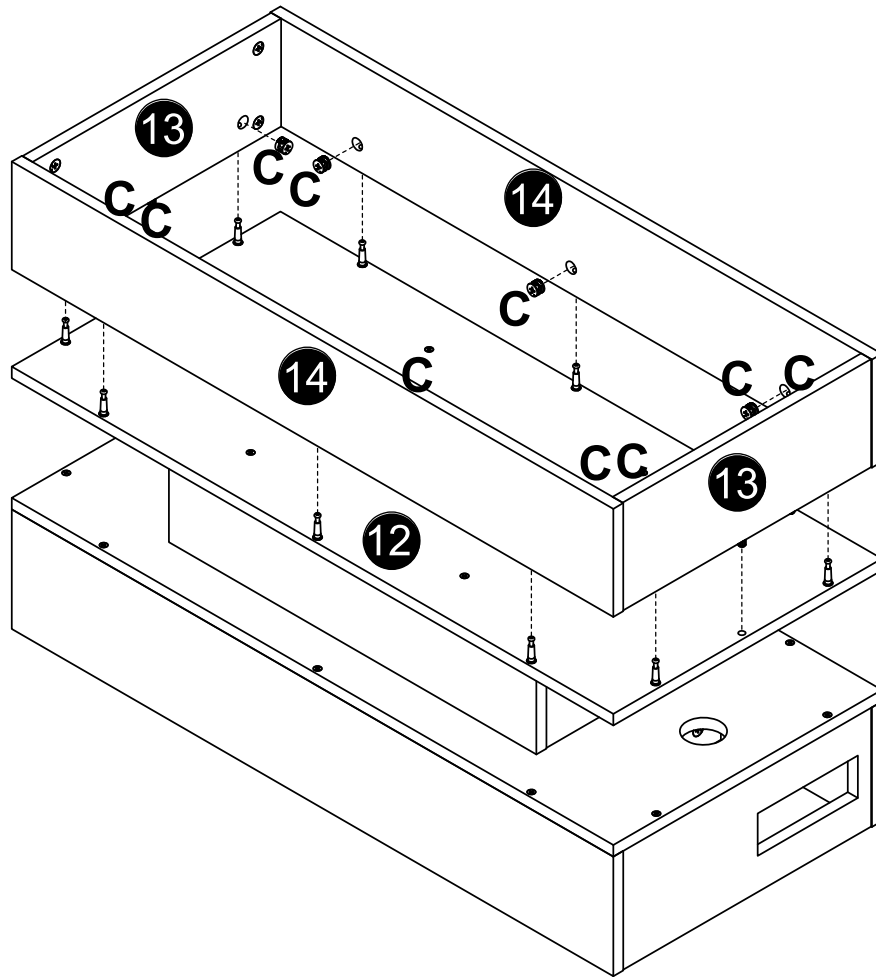
**13**

1 x1



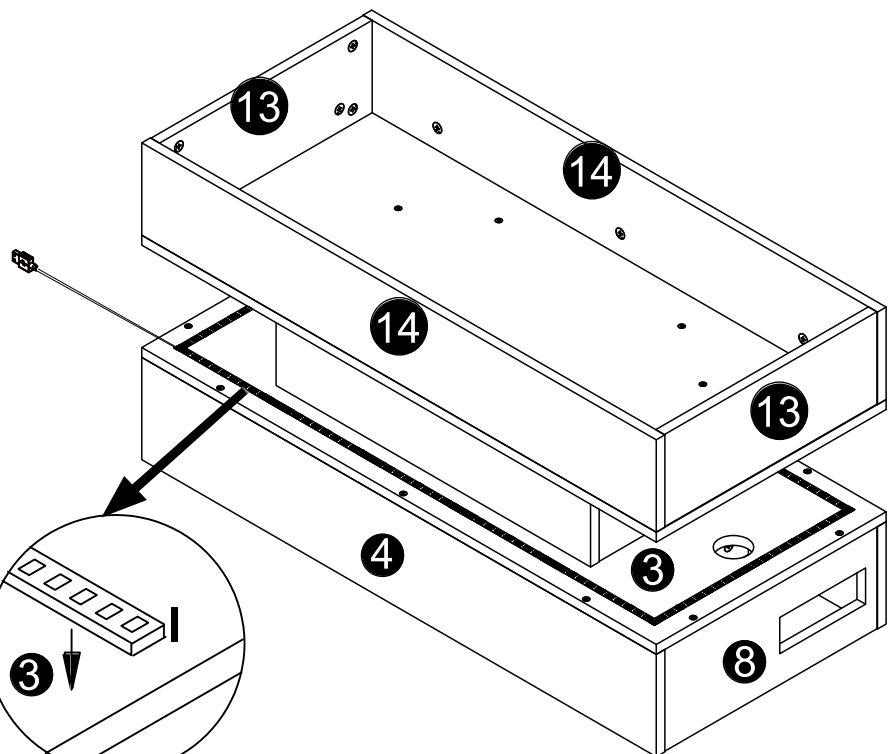
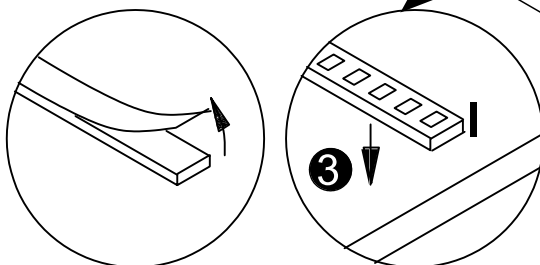

2400mm

EN: Tear off the back tape  
 FR: Déchirer le ruban adhésif arrière  
 DE: Reiß das hintere Band ab  
 IT: Rimuovere il nastro posteriore  
 ES: Arrancar la cinta trasera



DE: Scannen Sie den QR-Code, um die App zur Steuerung des LED-Lichts herunterzuladen.  
 EN: Scan the QR code to download the app to control the LED light.  
 IT: Scansiona il codice QR per scaricare l'app per controllare la luce LED.  
 FR: Scannez le code QR pour télécharger l'application afin de contrôler la lumière LED.  
 ES: Escanea el código QR para descargar la aplicación y controlar la luz LED.

14

Hx2 	Gx1 
3.5*14	

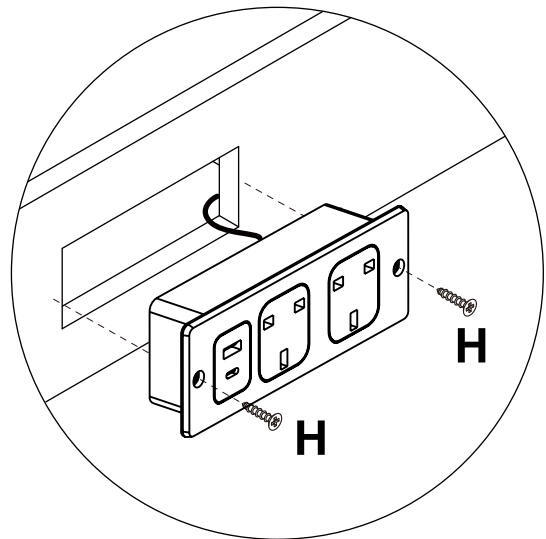
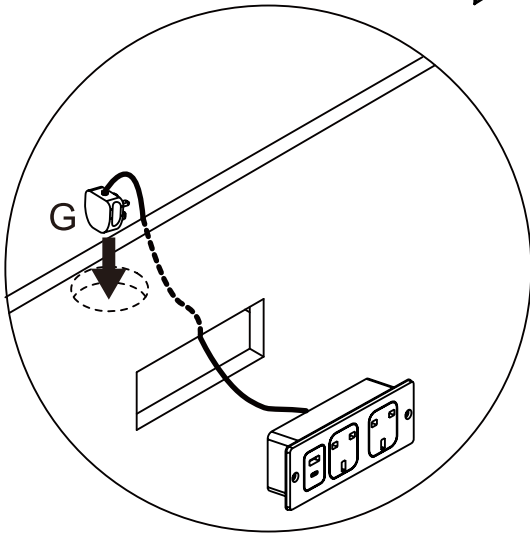
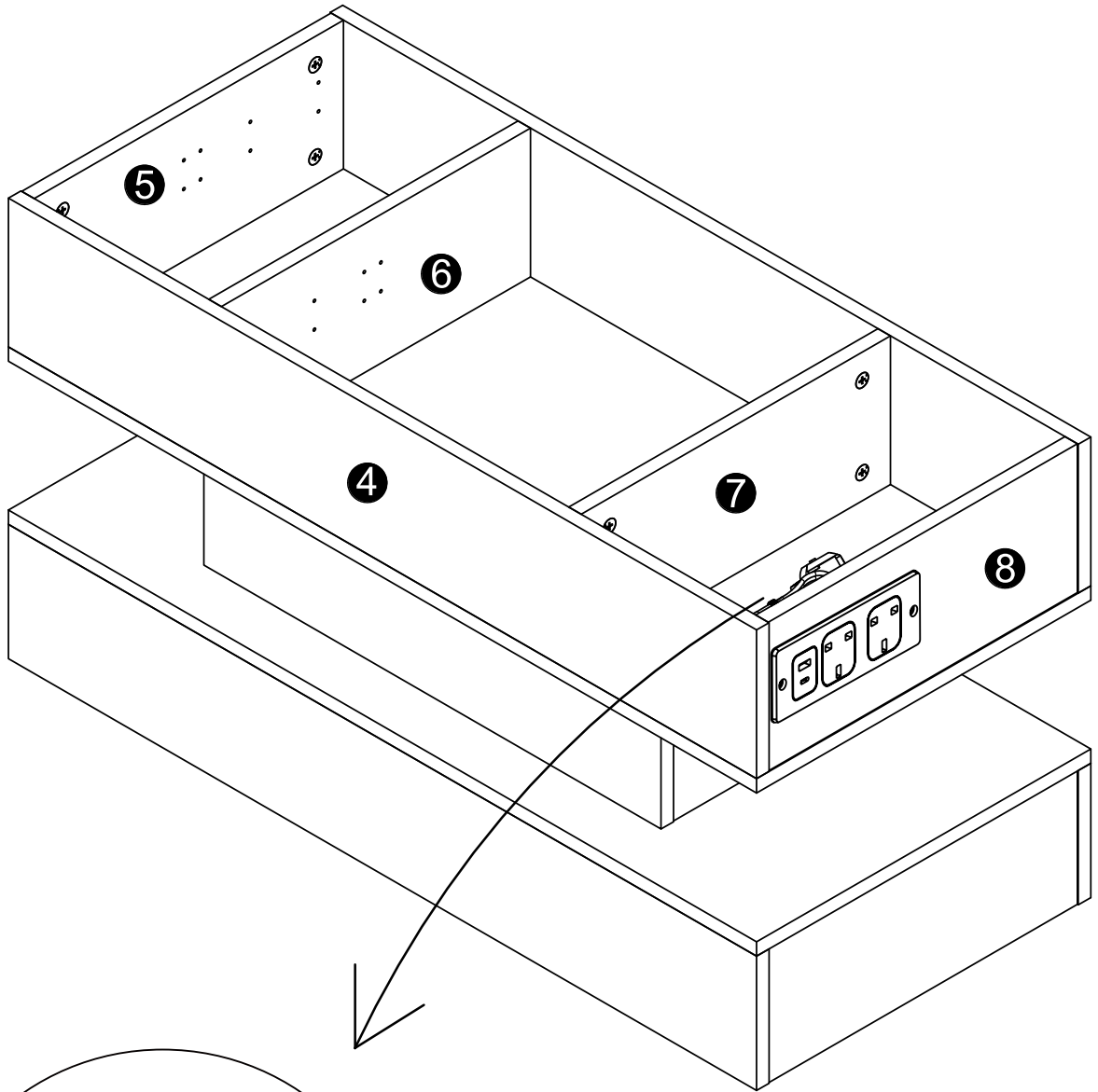

15

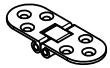
Ex18	Fx3
	
3.5*12	

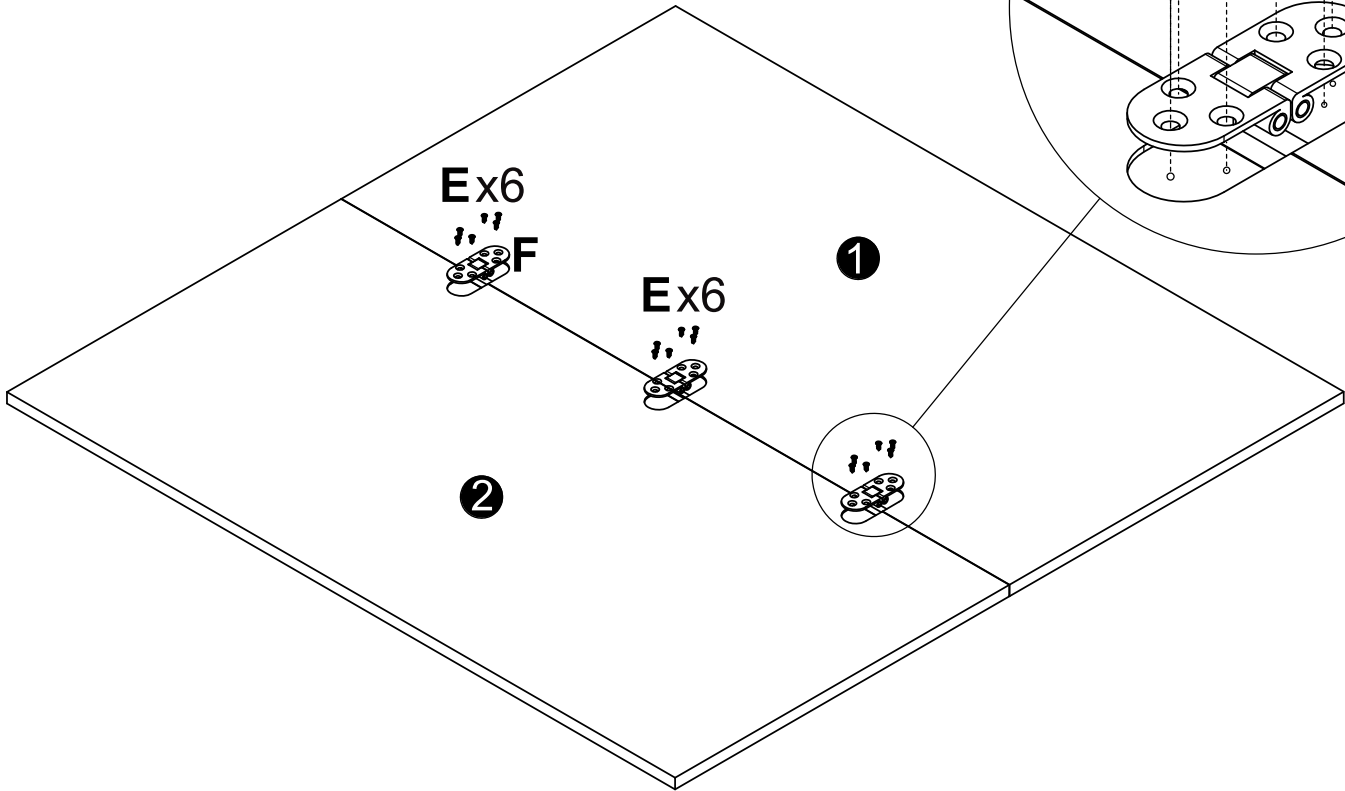
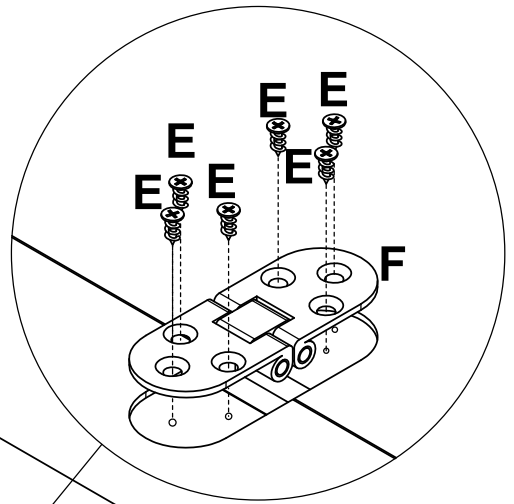
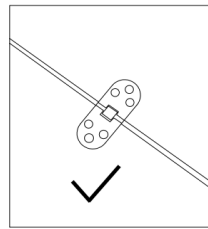
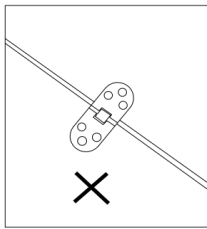

16

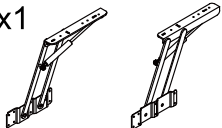
Hx8	Kx1
	
3.5*14	

**K**  
 Left Side  
 Linke Seite  
 Côté Gauche  
 Lado Izquierdo  
 Lato Sinistro

**K**  
 Right Side  
 Rechte Seite  
 Côté Droit  
 Lado Derecho  
 Lato Destro

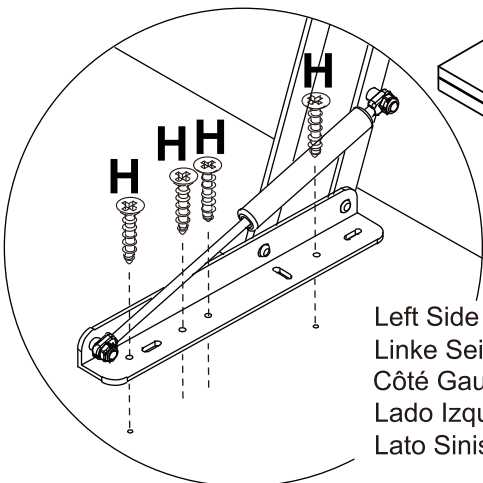

**H**  
 Left Side  
 Linke Seite  
 Côté Gauche  
 Lado Izquierdo  
 Lato Sinistro

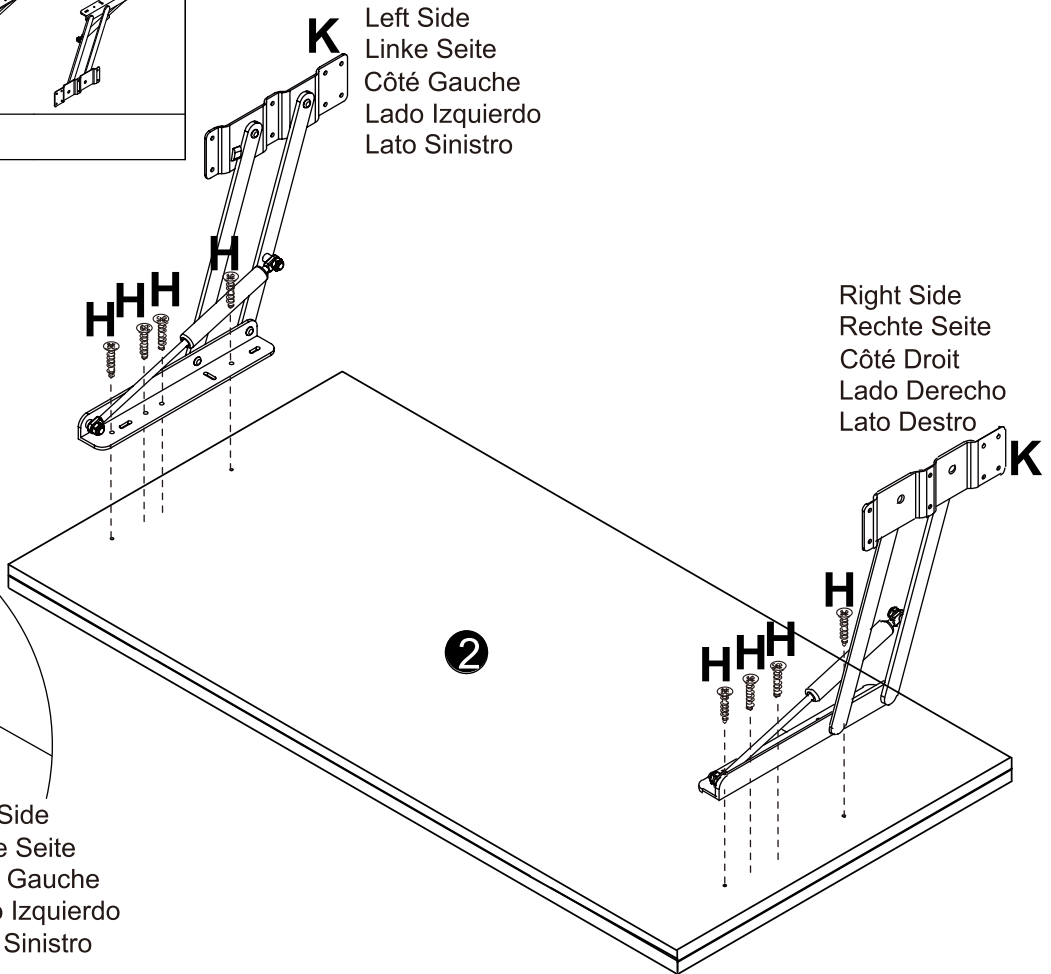

17

Hx8



Kx1

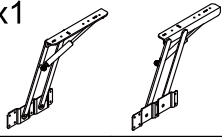

3.5\*14

Left Side  
Linke Seite  
Côté Gauche  
Lado Izquierdo  
Lato Sinistro

Right Side  
Rechte Seite  
Côté Droit  
Lado Derecho  
Lato Destro

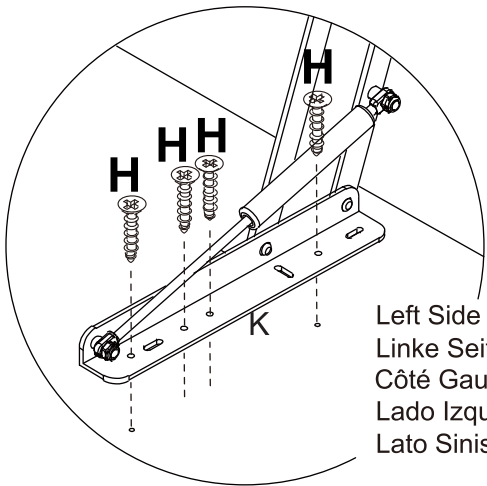
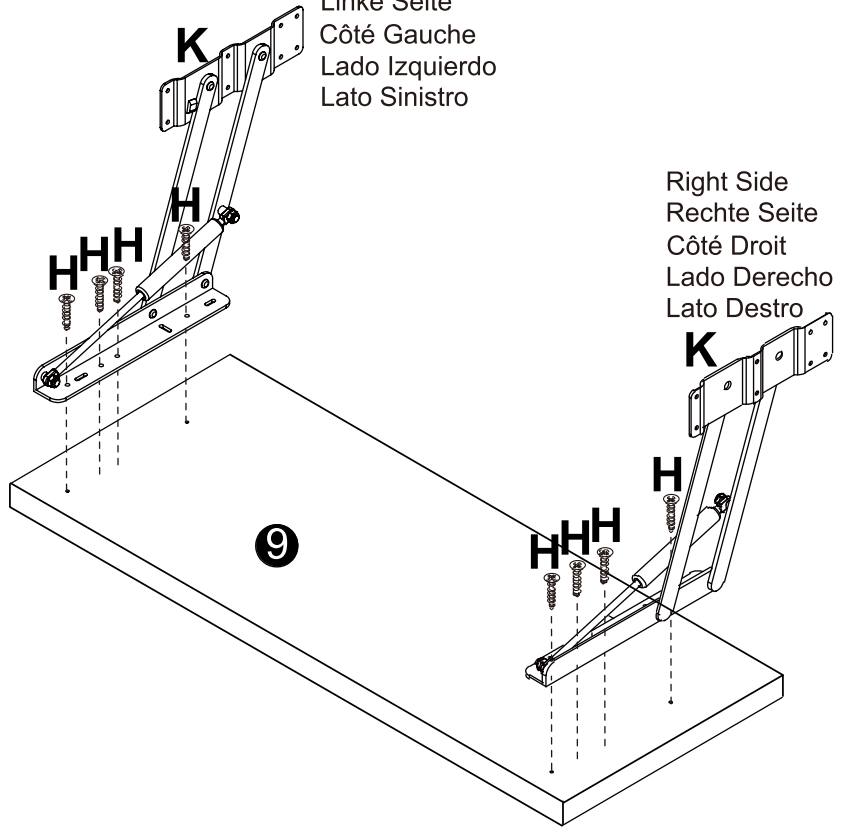

Left Side  
Linke Seite  
Côté Gauche  
Lado Izquierdo  
Lato Sinistro

18

Hx32



3.5\*14

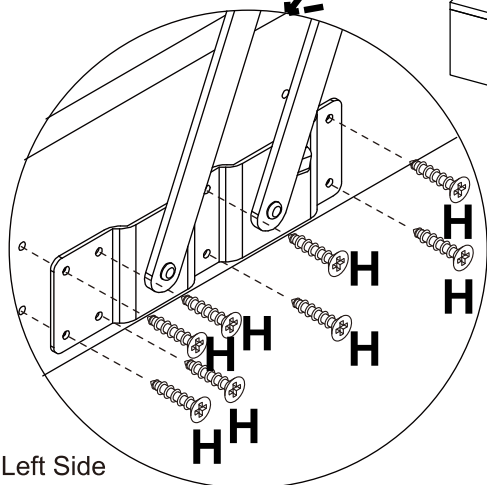
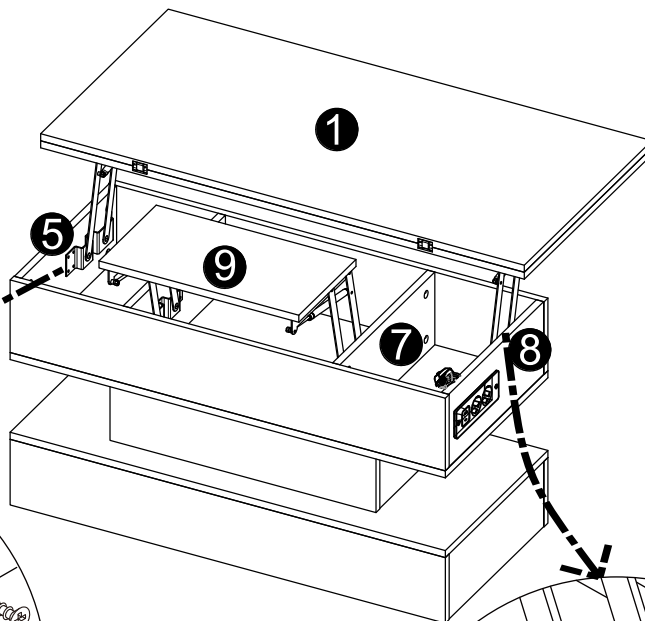

Left Side  
Linke Seite  
Côté Gauche  
Lado Izquierdo  
Lato Sinistro

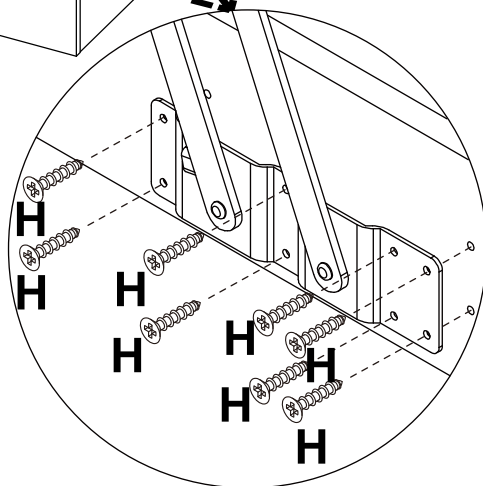

Right Side  
Rechte Seite  
Côté Droit  
Lado Derecho  
Lato Destro

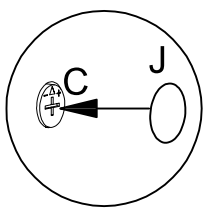
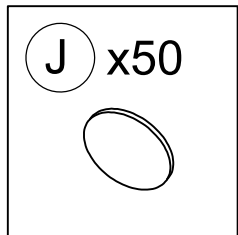
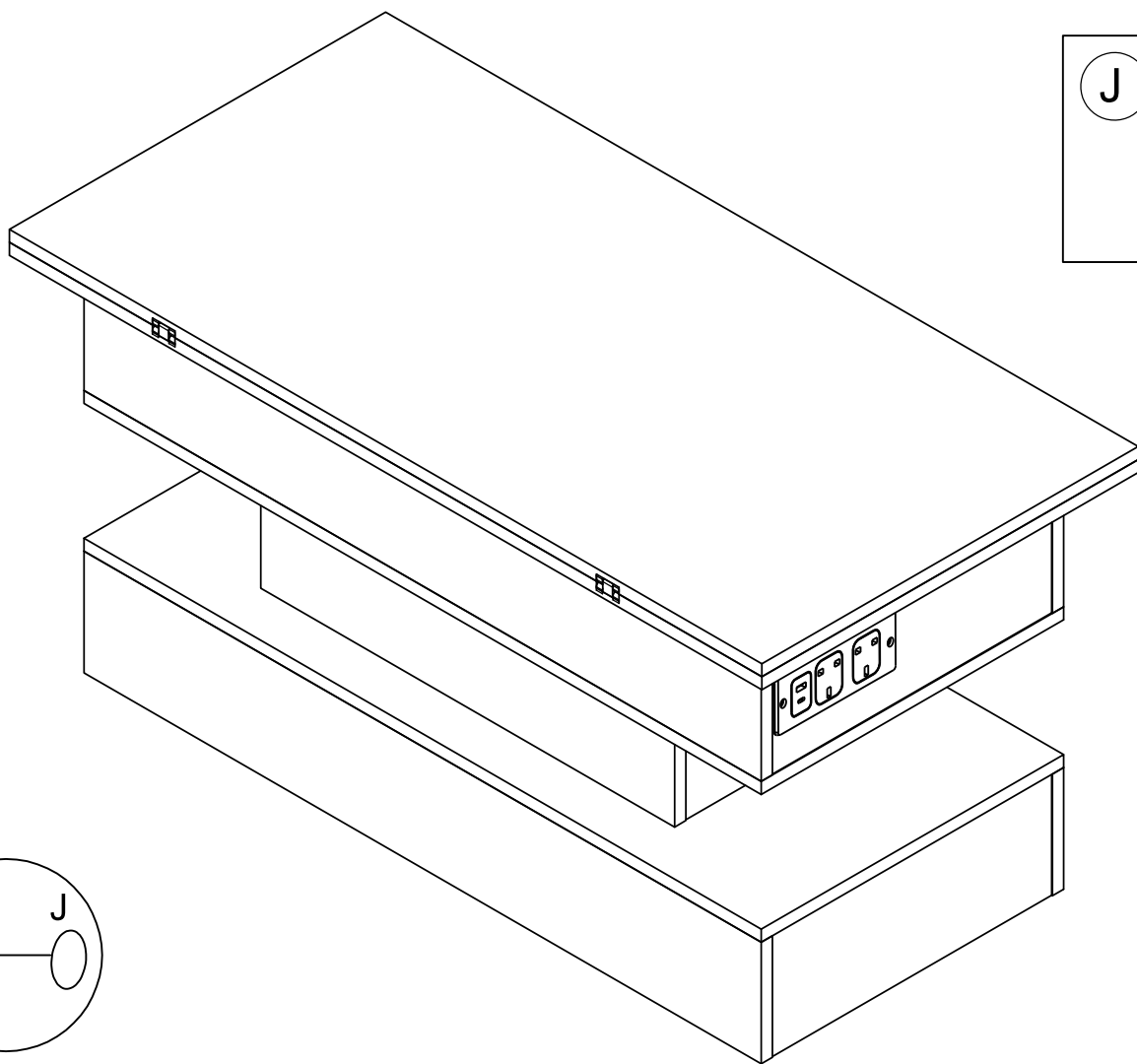

UK: After installing the product, stick the number J on the perforated position

FR: Une fois le produit installé, collez le numéro J à l'endroit où il y a des trous

DE: Nach der Installation des Produkts kleben Sie die Nummer J auf die perforierte Position

IT:Dopo l'installazione del prodotto, fissare il numero J sulla posizione perforata

ES:Después de instalar el producto, pegue el número J en la posición perforada

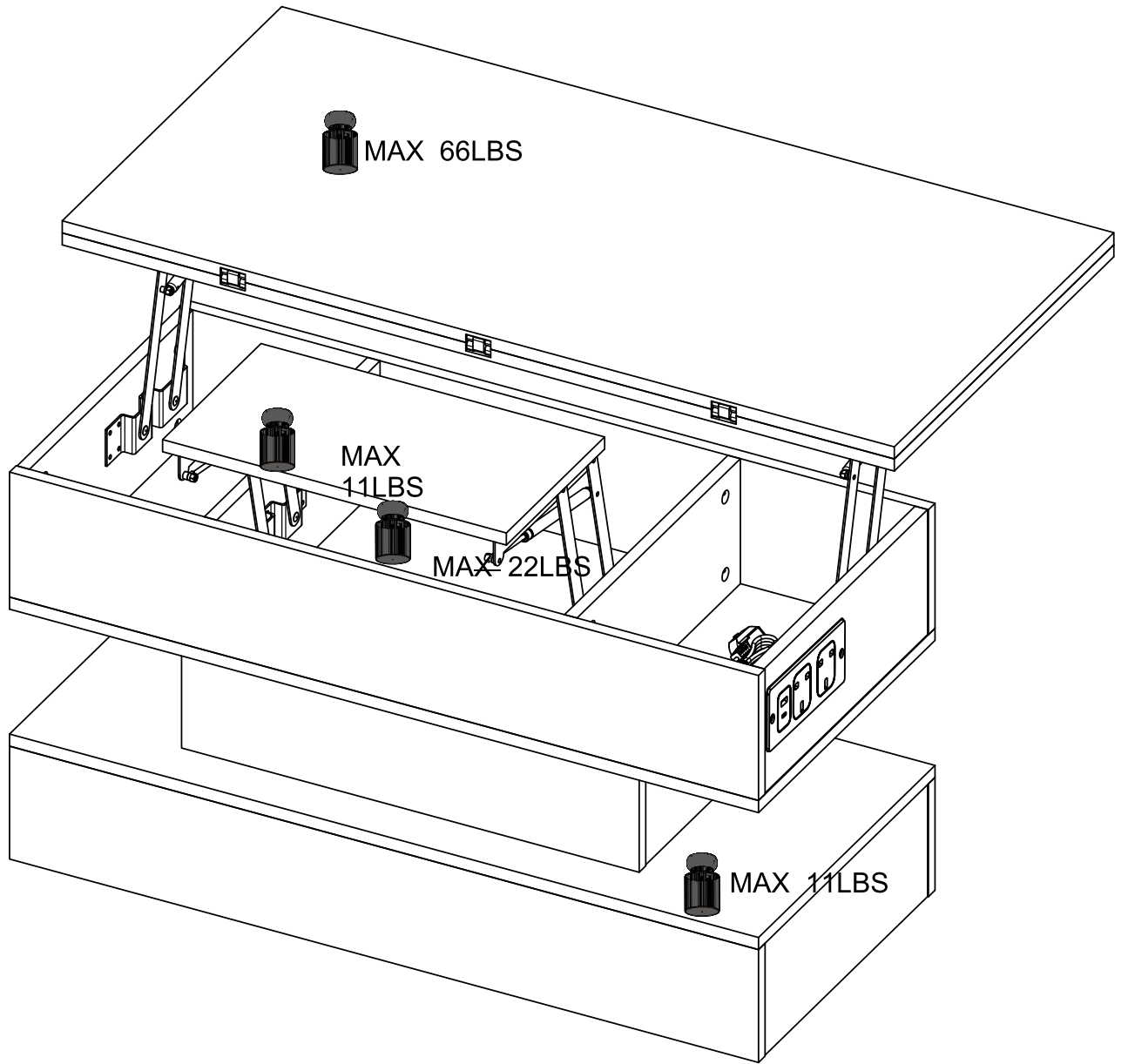

## APP-PROGRAMMANWENDUNG

Klicken, um  
Lampenliste  
anzuzeigen  
Farbrad  
wechseln

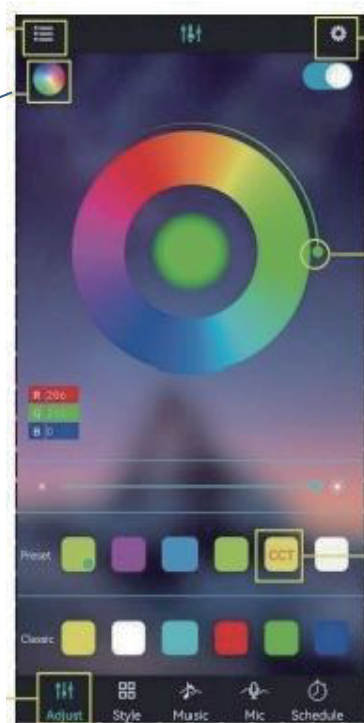

Klicken für  
Einstellungsansicht

Farbe anpassen

Farbanpassung  
per Quadrat-  
Symbol

Schnittstelle  
durch Klicken  
wechseln



## HINWEIS:

Detaillierte Anleitung im  
Menü "Guide"

## PRODUKTPARAMETER

- Bluetooth: BLEVA 2
- Eingangsspannung: 4.5~26V
- Betriebstemperatur: -25~75 ° C
- Abmessungen: 43×22×11 mm
- Gewicht: 30g
- Max. Leistung: 144W (24V)

## VERBINDUNGSSCHRITTE

- ① LED-Farbstreifen & Controller verbinden, Controller einschalten
- ② QR-Code scannen zum App-Download:



- ③ App starten, Controller suchen & verbinden
- ④ Bluetooth-Drahtlossteuerung genießen

## PRODUKTMERKMALE

- Direkte Handy-Steuerung (20m Reichweite)
- Automatische Verbindung in 5 Sekunden
- Musikrhythmus-Synchronisation
- Gruppensteuerung
- Helligkeits-/Geschwindigkeitsregelung
- Unterstützt bis 10m RGB(W)-Streifen
- Automatische Sprachumschaltung (DE/EN)

## ANIMATIONSEFFEKTE

- Farbverläufe
- Einfarbige/ Zweifarbige Gradienten
- Monochrome/Bunte Blinkereffekte
- Farbspringen
- Musikresponsive Effekte

## APP PROGRAM USAGE

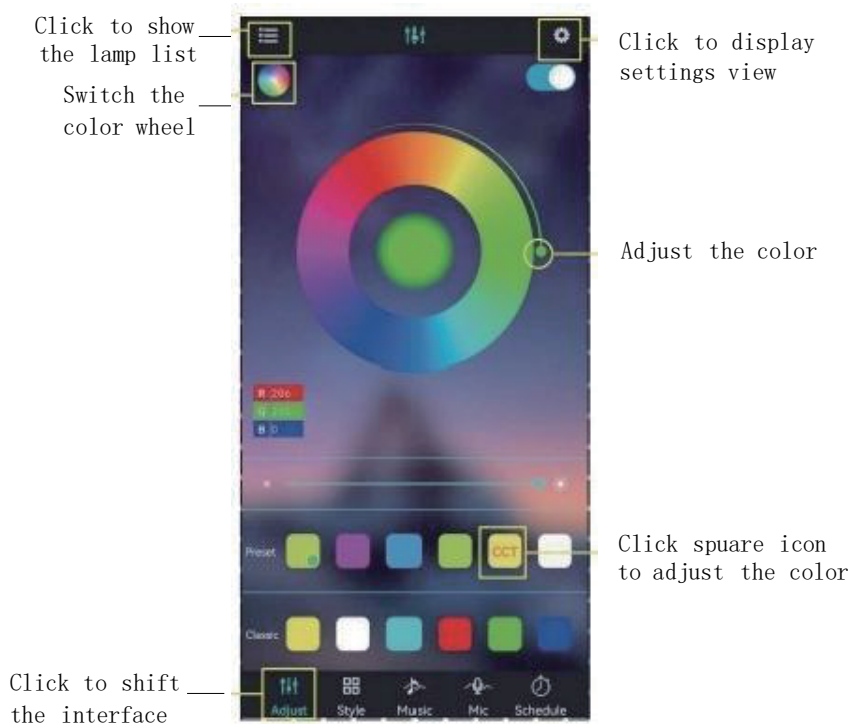

- Scan two-dimensional code download APP
- ①Connect LED color strip and controller, power on controller
  - ②Scan two-dimensional code download APP:



- ③Start APP, search and connect controller
- ④Enjoy the Bluetooth wireless control experience



Notes:  
detailed operating instructions,  
enter the menu "Guide":

Product Paramters:

- Bluetooth:BLEV4.2
- Input Voltage:4.5~26V
- Working Temp:-25~75℃
- Size:43\*22\*11mm
- Weight:30g
- Max Power:144W (24V)

LED mobile phone Bluetooth controllerProduct Features

- LED Bluetooth controller is directly via mobilephone control remote distance can reach 20m without the need to setupeasy to connect open the software within 5 seconds you can automatically connect the controller
- Flow the rhythm of the music changes
- Group control
- Brightness, speed addition and subtraction
- Maximum can be 10 meters RGB(W) strip
- The software shows that the text is based onthe language of the mobile phone set up automatic transformation of Chinese and English

ANIMATION EFFECTS:

- Colorful gradient
- All kinds of monochrome, double color gradient
- All kinds of monochrome, double color, colorfull flashing
- Colorful jump
- Follow the thymhm of the music chagnes

## APP-PROGRAMMANWENDUNG

Afficher la  
liste des lampes  
Farbrad  
Changer la  
Roue chromatique



Afficher les  
paramètres

Ajuster la couleur

Cliquez sur l'icône  
carrée pour ajuster  
la couleur.

Changer d'  
interface  
par clic



### REMARQUE :

Guide détaillé dans le menu  
"Guide"

### CARACTÉRISTIQUES

- Bluetooth : BLEVA 2
- Tension d'entrée : 4.5~26V
- Température : -25~75° C
- Dimensions : 43×22×11 mm
- Poids : 30g
- Puissance max : 144W (24V)

## ÉTAPES DE CONNEXION

- ① Connecter bande LED & contrôleur, allumer
- ② Scanner QR code pour télécharger l'app :



- ③ Lancer l'app, rechercher & connecter
- ④ Profiter du contrôle Bluetooth sans fil

## FONCTIONNALITÉS

- Contrôle direct par smartphone (20m)
- Connexion automatique en 5 secondes
- Synchronisation musicale
- Contrôle de groupe
- Réglage luminosité/vitesse
- Prise en charge bandes ≤10m RGB(W)
- Basculage automatique FR/EN

## EFFETS D'ANIMATION

- Dégradés de couleurs
- Dégradés uni/bicolores
- Clignotements mono/colorés
- Saut de couleurs
- Effets réactifs à la musique

## UTILIZZO APP



## PASSI CONNESSIONE

- ① Collega striscia LED & controller, accendi
- ② Scansiona QR code per scaricare APP:



- ③ Avvia APP, cerca & connetti controller
- ④ Goditi controllo wireless Bluetooth



## NOTA:

Guida completa nel menu "Guide"

## SPECIFICHE:

- Bluetooth: BLEVA 2
- Tensione ingresso: 4.5~26V
- Temperatura: -25~75° C
- Dimensioni: 43×22×11 mm
- Peso: 30g
- Potenza max: 144W (24V)

## CARATTERISTICHE

- Controllo diretto smartphone (20m)
- Connessione automatica in 5 secondi
- Sincronizzazione ritmo musicale
- Controllo di gruppo
- Regolazione luminosità/velocità
- Supporto strisce ≤10m RGB(W)
- Auto switch IT/EN

## EFFETTI ANIMAZIONE:

- Sfumature colore
- Gradienti mono/bicolori
- Luci lampeggianti mono/colorate
- Salto colori
- Effetti reattivi alla musica

## USO DE LA APLICACIÓN

Mostrar lista de —  
Lámparas  
Cambiar rueda de color

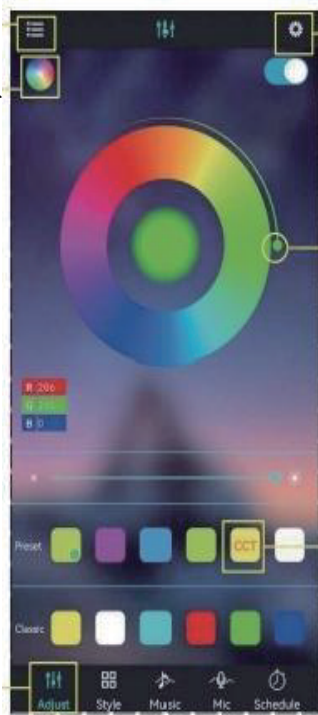

Ver ajustes

Ajustar el color

Clicar para ajustar color  
con icono cuadrado

Cambiar interfaz  
haciendo clic —



NOTA:

Guía completa en menú "Guide"

ESPECIFICACIONES:

- Bluetooth: BLEVA 2
- Voltaje entrada: 4.5~26V
- Temperatura: -25~75° C
- Tamaño: 43×22×11 mm
- Peso: 30g
- Potencia máx: 144W (24V)

## PASOS DE CONEXIÓN

- ① Conectar tira LED y controlador, encender
- ② Escanear QR para descargar APP:



- ③ Iniciar APP, buscar y conectar
- ④ Disfrutar control inalámbrico Bluetooth

## CARACTERÍSTICAS

- Control directo móvil (20m alcance)
- Conexión automática en 5 segundos
- Sincronización ritmo musical
- Control grupal
- Ajuste brillo/velocidad
- Soporte tiras ≤10m RGB(W)
- Auto cambio ES/EN

EFFECTOS DE ANIMACIÓN:

- Degradados de color
- Transiciones mono/bicolores
- Destellos monocromáticos/color
- Salto de colores
- Efectos reactivos a música

**Certificate No.** FCS202502375UK01

**Product** British socket

**Brand Name** Using

**Model(s) No.** YS-UK1660

**Series Model** YS-UK1661 YS-UK1662 YS-UK1663 YS-UK1664 YS-UK1665  
YS-MU1661 NS-MU1662 NS-MU1663 YS-MU1664 NS-MU1665  
YS-EU1661 YS-EU1662 YS-EU1663 YS-EU1664 YS-EU1665  
YS-MU1660 YS-EU1660

**Holder** Shenzhen Using Intelligent Technology CO.,LTD.

**Address** A1605, Excellence Meilin Center Square (South District), No. 126  
Zhongkang Road, Meidu Community, Meilin Street, Futian District,  
Shenzhen

**Manufacturer** Shenzhen Using Intelligent Technology Co., Ltd. Dongguan Branch

**Address** 5th Floor, Building 2, No. 55 West Road, Shilong Section, Dongjiang  
Avenue, Shilong Town, Dongguan City, Guangdong Province

**Report No.** FCS202502375E01

**TEST STANDARDS:**

BS EN 55032:2015/A1:2020;BS EN 55035:2017/A11:2020;

BS EN IEC 61000-3-2:2019/A1:2021;BS EN 61000-3-3:2013/A2:2021/AC:2022-01;

BS EN 61000-4-2:2009;BS EN IEC 61000-4-3:2020;BS EN 61000-4-4:2012;

BS EN 61000-4-5:2014/A1:2017;BS EN 61000-4-6:2014/AC:2015;

BS EN IEC 61000-4-11:2020

This Attestation of Conformity is issued on a voluntary basis according to the UKCA\_EMCC Directive - Electromagnetic Compatibility Regulations 2016 to electromagnetic compatibility. After preparation of the necessary UK regulation technical documentation as well as the UK declaration of conformity the required UKCA marking can be affixed on the product. Other applicable UK regulations have to be observed.

The submitted sample of the above equipment has been tested and found to comply with the following UK legislation:

**UKCA\_EMCC Directive - Electromagnetic Compatibility Regulations 2016**



Approved by: *Jack Wang*

Mar. 10, 2025



Jack Wang/Managerial

The statement is based on a single evaluation of the sample of above mentioned product(s). It does not imply an assessment of the whole production.

**Dongguan Funas Testing Technology Co.,Ltd.**

Add: Room 105, 1/F., Baohao Technology Building 1, No.15, Gongye West Road,  
Songshan Lake Hi-Tech Industrial Area, Dongguan, Guangdong, China

Tel: 0769-27280901 Web:<http://www.fcs-lab.com> E-mail:[andy.yue@fcs-lab.com](mailto:andy.yue@fcs-lab.com)

**Certificate No.** FCS202502375UK02

**Product** British socket

**Brand Name** Using

**Model(s) No.** YS-UK1660

**Series Model** YS-UK1661 YS-UK1662 YS-UK1663 YS-UK1664 YS-UK1665  
YS-MU1661 NS-MU1662 NS-MU1663 YS-MU1664 NS-MU1665  
YS-EU1661 YS-EU1662 YS-EU1663 YS-EU1664 YS-EU1665  
YS-MU1660 YS-EU1660

**Holder** Shenzhen Using Intelligent Technology CO.,LTD.

**Address** A1605, Excellence Meilin Center Square (South District), No. 126  
Zhongkang Road, Meidu Community, Meilin Street, Futian District,  
Shenzhen

**Manufacturer** Shenzhen Using Intelligent Technology Co., Ltd. Dongguan Branch

**Address** 5th Floor, Building 2, No. 55 West Road, Shilong Section, Dongjiang  
Avenue, Shilong Town, Dongguan City, Guangdong Province

**Report No.** FCS202502375A01

**TEST STANDARDS:**

BS EN IEC 62368-1:2024 + A11:2024

This Attestation of Conformity is issued on a voluntary basis according to the Electromagnetic Equipment (Safety) 2016 relating to electromagnetic compatibility. After preparation of the necessary UK regulation technical documentation as well as the UK declaration of conformity the required UKCA marking can be affixed on the product. Other applicable UK regulations have to be observed.

The submitted sample of the above equipment has been tested and found to comply with the following UK legislation:

**UKCA\_LVD Directive - Electromagnetic Equipment (Safety) Regulations 2016**

Approved by:

*Jack Wang*  
Mar. 10, 2025

Jack Wang/Managerial

**UK  
CA**

The statement is based on a single evaluation of the sample of above mentioned product(s). It does not imply an assessment of the whole production.

**Dongguan Funas Testing Technology Co.,Ltd.**

Add: Room 105, 1/F., Baohao Technology Building 1, No.15, Gongye West Road,  
Songshan Lake Hi-Tech Industrial Area, Dongguan, Guangdong, China  
Tel: 0769-27280901, Web:<http://www.fcs-lab.com>, E-mail:[andy.yue@fcs-lab.com](mailto:andy.yue@fcs-lab.com)



# CERTIFICATE OF CONFORMITY

Certificate No.: KEYS241104015001RH-03R1

**Applicant** : SHENZHEN Using Intelligent Technology CO.,LTD.  
**Address** : No. 22 Chenwu Road, Dakang Community, Yuanshan Street, Longgang District, Shenzhen  
**Manufacturer** : Shenzhen Yousheng Intelligent Technology Co., Ltd. Dongguan Branch  
**Address** : Room 504, Building 2, No. 55 West Shilong Section, Dongjiang Avenue, Shilong Town, Dongguan City, Guangdong Province  
**Sample Name** : British socket  
**Trademark** : Using  
**Main Model** : YS-UK1660  
**Additional model** : YS-UK1661,YS-UK1662,YS-UK1663,YS-UK1664,YS-UK1665,  
IYS-MU1661,YS-MU1662,YS-MU1663,YS-MU1664,YS-MU1665,  
YS-EU1661,YS-EU1662,YS-EU1663,YS-EU1664,YS-EU1665,YS-8033

**RoHS 2.0 Directive (EU) 2015/863 and (EU)2017/2102 amending Annex II to Directive 2011/65/EU.**

The standard(s) used for showing compliance with the essential requirements:

**Applicable Standard(s)**      **IEC 62321-3-1: 2013**  
**IEC 62321-4:2013 +AMD1:2017**  
**IEC 62321-5:2013**  
**IEC 62321-6:2015**  
**IEC 62321-7-1:2015**  
**IEC 62321-7-2:2017**  
**IEC 62321-8:2017**

The EUT described above has been consolidated by us and found in compliance with the council RoHS 2.0 Directive (EU) 2015/863 and (EU)2017/2102 amending Annex II to Directive 2011/65/EU.

The certificate applies to the tested sample above mentioned only and shall not imply an assessment of the whole production. It is only valid in connection with the test report number. KEYS241104015001RH-03R1

# RoHS

  
**Tony Qian/Approved Signatory**  
Date: Nov.06, 2024



Scan to view  
the original file

**Guangdong KEYS Testing Technology Co., Ltd.**

Address: Building 1, No.18, Shihuan Road, Dongcheng Subdistrict, Dongguan, Guangdong, China  
Tel:+ 86-0769-89798319 <http://www.keys-lab.com> E-mail: [info@keys-lab.com](mailto:info@keys-lab.com)



# Certificate of Compliance

Certificate Number: ZHT-250114113C01C

**Applicant Name / Zertifikatsinhaber** : Shenzhen Dengdai Yunlian Lighting Co., Ltd  
**Address / Adresse** : 2nd Floor, Building A, No. 15 Jinkui East Road, Kuiyong Street, Dapeng New District, Shenzhen, Guangdong, China  
**Manufacturer / Hersteller** : Shenzhen Dengdai Yunlian Lighting Co., Ltd  
**Address / Adresse** : 2nd Floor, Building A, No. 15 Jinkui East Road, Kuiyong Street, Dapeng New District, Shenzhen, Guangdong, China  
**Product / Produkt** : CCT led strips  
**Main Model(s) / Hauptmodell(e)** : 2835 CCT-05  
**Additional Model(s) / Zusätzliche(s) Modell(e)** : 2835 CCT-03, 2835 CCT-12, 2835 CCT-24  
**Trade Mark / Warenzeichen** :   
**Test Standard / Geprüft nach** : IEC 62321-3-1:2013, IEC 62321-4:2013+A1:2017, IEC 62321-5:2013, IEC 62321-6:2015, IEC 62321-7-1:2015, IEC 62321-7-2:2017, IEC 62321-8:2017  
**Test Report No./Bericht Nr** : ZHT-250114113C01

The EUT described above has been consolidated by us and found in compliance with the council RoHS Directive 2011/65/EU Annex II amending Annex (EU)2015/863. It is possible to use CE marking to demonstrate the compliance with this RoHS Directive. It is only valid in connection with the test report.

After preparation of the necessary technical documentation according the requirement of EN IEC63000:2018 as well as the verification of conformity the CE marking as shown below can be affixed on the equipment.



The information of the certificate can be checked through [www.zht-lab.cn](http://www.zht-lab.cn).  
The CE mark which is shown on the certificate can only be used under the conditions that the products complete with all of the relevant Directives of EC Declaration of Conformity.  
The Manufacturer should be responsible for the internal production control so that the products complied with the essential requirements of the above mentioned Directive(s). Certificate holder must notify all changes to the original certification laboratory of Guangdong Zhonghan Testing Technology Co., Ltd.



**Guangdong Zhonghan Testing Technology Co., Ltd.**  
**Address:** Room 104/201, Building 1, Yibaolai Industrial Park, Qiaotou, Fuhai Subdistrict, Bao'an District, Shenzhen, Guangdong, China  
**Tel.:** +86-755-27782934 **Http://**[www.zht-lab.cn](http://www.zht-lab.cn) **E-mail:** [admin@zht-lab.cn](mailto:admin@zht-lab.cn)



# Certificate of Compliance

**Certificate Number: ZHT-251124124E01C**

**Certificate's Holder** : Shenzhen Dengdai Yunlian Lighting Co., Ltd  
**Zertifikatsinhaber** : 2nd Floor, Building A, No. 15 Jinkui East Road, Kuiyong Street,  
DapengNew District, Shenzhen, Guangdong, China

**Manufacturer** : Shenzhen Dengdai Yunlian Lighting Co., Ltd  
**Hersteller** : 2nd Floor, Building A, No. 15 Jinkui East Road, Kuiyong Street,  
DapengNew District, Shenzhen, Guangdong, China

**Trade Mark** : VITO  
**Warenzeichen**

**Product** : LED light strip  
**Produkt**

**Model(s)** : 2835 CCT-05  
**Modell** : RGB-05

**Test Standard** : EN IEC 55015:2019+A11:2020  
**Prüfnorm** : EN IEC 61000-3-2:2019 + A1:2021 + A2:2024  
EN 61000-3-3:2013 + A1:2019 + A2:2021  
EN IEC 61547:2023

**Test Report No.** : ZHT-251124124E01  
**Bericht Nr**

This Attestation of Compliance is issued on a voluntary basis for electrical equipment below the voltage limits of EMC Directive 2014/30/EU. The essential requirements are fulfilled accordingly based on the technical specifications applicable at the time of issuance. It is only valid in connection with the test report.



The information of the certificate can be checked through [www.zht-lab.cn](http://www.zht-lab.cn). The CE mark which is shown on the certificate can only be used under the conditions that the products complete with all of the relevant Directives of EC Declaration of Conformity. The Manufacturer should be responsible for the internal production control so that the products complied with the essential requirements of the above mentioned Directive(s). Certificate holder must notify all changes to the original certification laboratory of Guangdong Zhonghan Testing Technology Co., Ltd.



**Guangdong Zhonghan Testing Technology Co., Ltd.**

**Address: Room 104/201, Building 1, Yibaolai Industrial Park, Qiaotou, Fuhai Subdistrict, Bao'an District, Shenzhen, Guangdong, China**

**Tel.: +86-755-27782934** [Http://www.zht-lab.cn](http://www.zht-lab.cn) **E-mail:admin@zht-lab.cn**



# Certificate of Compliance

**Certificate Number: ZHT-251124124S01C**

**Certificate's Holder** : Shenzhen Dengdai Yunlian Lighting Co., Ltd  
**Zertifikatsinhaber** 2nd Floor, Building A, No. 15 Jinkui East Road, Kuiyong Street,  
DapengNew District, Shenzhen, Guangdong, China

**Manufacturer** : Shenzhen Dengdai Yunlian Lighting Co., Ltd  
**Hersteller** 2nd Floor, Building A, No. 15 Jinkui East Road, Kuiyong Street,  
DapengNew District, Shenzhen, Guangdong, China

**Trade Mark** : VITO  
**Warenzeichen**

**Product** : LED light strip  
**Produkt**

**Model(s)** : 2835 CCT-05,  
**Bezeichnung** RGB-05

**Test Standard** : EN 60598-2-21:2015  
**Geprüft nach** EN IEC 60598-1:2024+A11:2024  
EN IEC 62031:2020+A11:2021

**Test Report No.** : ZHT-251124124S01  
**Bericht Nr**

This Certificate of Compliance is issued on a voluntary basis for General Product Safety Regulation of directive (EU)2023/988. The essential requirements are fulfilled accordingly based on the technical specifications applicable at the time of issuance. It is only valid in connection with the test report.



The information of the certificate can be checked through [www.zht-lab.cn](http://www.zht-lab.cn).  
The CE mark which is shown on the certificate can only be used under the conditions that the products complete with all of the relevant Directives of EC Declaration of Conformity.  
The Manufacturer should be responsible for the internal production control so that the products complied with the essential requirements of the above mentioned Directive(s). Certificate holder must notify all changes to the original certification laboratory of Guangdong Zhonghan Testing Technology Co., Ltd.



**Guangdong Zhonghan Testing Technology Co., Ltd.**  
**Address:** Room 104/201, Building 1, Yibaolai Industrial Park, Qiaotou, Fuhai Subdistrict, Bao'an District, Shenzhen, Guangdong, China  
**Tel.:** +86-755-27782934 **Http://**[www.zht-lab.cn](http://www.zht-lab.cn) **E-mail:** [admin@zht-lab.cn](mailto:admin@zht-lab.cn)



# Certificate of Compliance

**Certificate Number: ZHT-250114113R01C**

**Applicant Name / Zertifikatsinhaber** : Shenzhen Dengdai Yunlian Lighting Co., Ltd  
**Address / Adresse** : 2nd Floor, Building A, No. 15 Jinkui East Road, Kuiyong Street, Dapeng New District, Shenzhen, Guangdong, China  
**Manufacturer / Hersteller** : Shenzhen Dengdai Yunlian Lighting Co., Ltd  
**Address / Adresse** : 2nd Floor, Building A, No. 15 Jinkui East Road, Kuiyong Street, Dapeng New District, Shenzhen, Guangdong, China  
**Product / Produkt** : CCT led strips  
**Main Model(s) / Hauptmodell(e)** : 2835 CCT-05  
**Additional Model(s) / Zusätzliche(s) Modell(e)** : 2835 CCT-03, 2835 CCT-12, 2835 CCT-24  
**Trade Mark / Warenzeichen** :   
**Test Standard / Geprüft nach** : EN62479:2010, EN IEC 62368-1:2024+A11:2024  
ETSI EN 301 489-1 V2.2.3, ETSI EN 300 328 V 2.2.2  
ETSI EN 301 489-17 V3.2.4  
**Test Report No./Bericht Nr** : ZHT-250114113R01

The certificate is issued in accordance with annex III of the RED Directive 2014/53/EU of 13th March, 2014

This certificate of conformity is based on a single evaluation of the submitted sample(s) of the above mentioned product. It does not imply an assessment of the whole production and other relevant directives have to be observed.



The information of the certificate can be checked through [www.zht-lab.cn](http://www.zht-lab.cn).  
The CE mark which is shown on the certificate can only be used under the conditions that the products complete with all of the relevant Directives of EC Declaration of Conformity.  
The Manufacturer should be responsible for the internal production control so that the products complied with the essential requirements of the above mentioned Directive(s). Certificate holder must notify all changes to the original certification laboratory of Guangdong Zhonghan Testing Technology Co., Ltd.



**Guangdong Zhonghan Testing Technology Co., Ltd.**  
**Address:** Room 104/201, Building 1, Yibaolai Industrial Park, Qiaotou, Fuhai Subdistrict, Bao'an District, Shenzhen, Guangdong, China  
**Tel.:** +86-755-27782934 **Http://**[www.zht-lab.cn](http://www.zht-lab.cn) **E-mail:** [admin@zht-lab.cn](mailto:admin@zht-lab.cn)



# Certificate of Compliance

**Certificate Number: ZHT-250414126E01C**

**Certificate's Holder** : Shenzhen Dengdai Yunlian Lighting Co., Ltd  
**Zertifikatsinhaber** : 2nd Floor, Building A, No. 15 Jinkui East Road, Kuiyong Street,  
DapengNew District, Shenzhen, Guangdong, China

**Manufacturer** : Shenzhen Dengdai Yunlian Lighting Co., Ltd  
**Hersteller** : 2nd Floor, Building A, No. 15 Jinkui East Road, Kuiyong Street,  
DapengNew District, Shenzhen, Guangdong, China

**Trade Mark** : VITO  
**Warenzeichen** :

**Product** : LED light strip  
**Produkt** :

**Model(s)** : 2835 CCT-05  
**Modell** : RGB-05

**Test Standard** : BS EN IEC 55015:2019+A11:2020  
**Prufnorm** : BS EN IEC 61547:2023  
BS EN IEC 61000-3-2:2019+A2:2024  
BS EN 61000-3-3:2013+A2:2021

**Test Report No.** : ZHT-250414126E01  
**Bericht Nr** :

This certificate of compliance is issued according to the UK legislation: Electromagnetic Compatibility Regulations 2016(S.I. 2016/1091), Referred to as the UK Electromagnetic Compatibility. It confirms that the listed product complies with all essential requirements of the Electromagnetic Compatibility Regulations 2016 and applies only to the sample and its technical documentation submitted to Guangdong Zhonghan Testing Technology Co., Ltd.(ZHT) for testing. It is only valid in connection with the test report number: ZHT-250414126E01. So ZHT here by acknowledges that the Manufacturer may issue a COC apply the UKCA marketing in according with United Kingdom Union Rules. After preparation of the necessary technical documentation (Which must be kept for up to 10 years after the product is placed on the GB market as well as the UK declaration of conformity, the required UKCA marking can be affixed on the product. Other relevant Regulations have to be observed.

**UK  
CA**



The information of the certificate can be checked through [www.zht-lab.cn](http://www.zht-lab.cn). The UKCA mark which is shown on the certificate can only be used under the conditions that the products complete with all of the relevant Directives of EC Declaration of Conformity. The Manufacturer should be responsible for the internal production control so that the products complied with the essential requirements of the above mentioned Directive(s). Certificate holder must notify all changes to the original certification laboratory of Guangdong Zhonghan Testing Technology Co., Ltd.



**Guangdong Zhonghan Testing Technology Co., Ltd.**

**Address: Room 104/201, Building 1, Yibaolai Industrial Park, Qiaotou, Fuhai Subdistrict, Bao'an District, Shenzhen, Guangdong, China**

**Tel.: +86-755-27782934 Http://www.zht-lab.cn E-mail:admin@zht-lab.cn**

CERTIFICATE OF COMPLIANCE