

Assembly Instruction

N890P388285+ N890P388287

Kitchen island cabinet

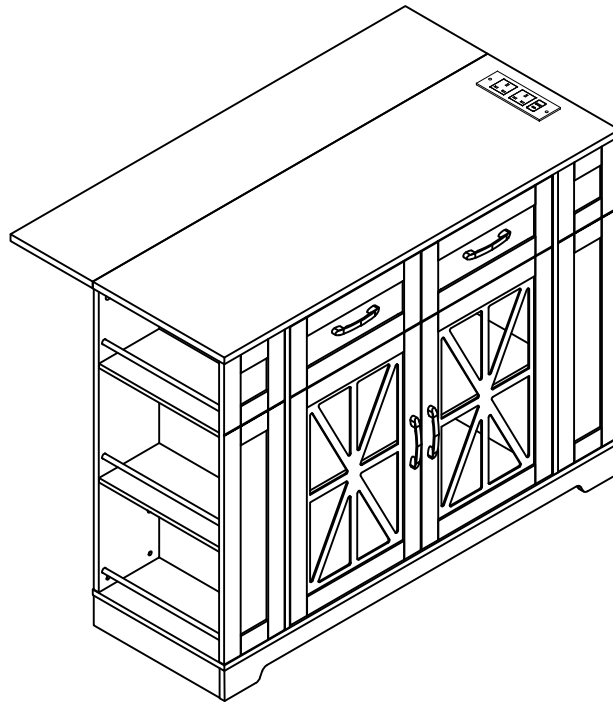

Importer	COMHARBOR LIMITED
Add	Unit C, Swift Point, Cosford Lane, Rugby, CV21 1PY, GB
Email / URL	harborcomhar@gmail.com
Manufacturer	FUJIAN FENLIN HOUSEWARE CO.,LTD.
Add	NO.65 QIAOYANG,XIAZHUANG VILLAGE,TAZHUANG TOWN,MINQING COUNTY,FUZHOU CITY,FUJIAN PROVINCE
Email / URL	hansen_zj@163.com
Product identification	C328UZJ20251013CX
Made in	China
	COMHARBOR LIMITED Unit C, Swift Point, Cosford Lane, Rugby, CV21 1PY, GB harborcomhar@gmail.com

Importeur	Decobus Handel GmbH
Adresse	Innungsstraße 9, 21244 Buchholz, Deutschland
URL	https://www.decobusgroup.de
Hersteller	FUJIAN FENLIN HOUSEWARE CO.,LTD.
Adresse	NO.65 QIAOTOUYANG,XIAZHUANG VILLAGE,TAZHUANG TOWN, MINQING COUNTY,FUZHOU CITY,FUJIAN PROVINCE
Email	hansen_zj@163.com
	Decobus Handel GmbH Innungsstraße 9, 21244 Buchholz, Deutschland https://www.decobusgroup.de
	Hergestellt in China

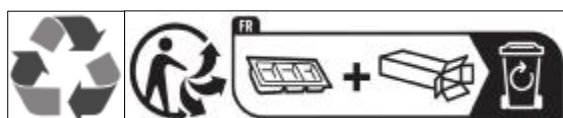

DE: Unser Produkt wird Ihnen in 2 Paketen geliefert. Die Lieferzeiten dieser 2 Pakete können abweichen, bitte haben Sie etwas Geduld und vielen Dank für Ihr Verständnis. Bitte lesen Sie diese Anweisungen vollständig durch, bevor Sie mit der Montage beginnen: Erforderliches Werkzeug: Kreuzschlitzschraubendreher (mittel und groß)

1. Überprüfen Sie, ob alle auf den folgenden Seiten aufgeführten Komponenten und Werkzeuge vorhanden sind.
 2. Entfernen Sie alle Zubehörteile aus den Plastiktüten und teilen Sie sie in ihre Gruppen auf.
 3. Halten Sie Kinder und Tiere vom Arbeitsbereich fern, es besteht Erstickungsgefahr durch Kleinteile wenn verschluckt.
 4. Stellen Sie sicher, dass Sie genügend Platz zum Anordnen der Teile haben, bevor Sie beginnen.
 5. Stellen Sie sich während der Montage nicht auf das Produkt und belasten Sie es nicht, da dies zu Schäden führen kann.
 6. Bauen Sie den Artikel so nah wie möglich an seiner endgültigen Position (im selben Raum) zusammen.
 7. Stellen Sie das Gerät auf eine weiche, ebene Oberfläche, um eine Beschädigung des Geräts oder Ihres Bodens zu vermeiden.
 8. Teile der Montage lassen sich einfacher mit 2 Personen durchführen.
 9. Um die Wahrscheinlichkeit einer Beschädigung Ihres Produkts zu verringern, stellen Sie bitte sicher, dass Ihre Bohrmaschine auf ein niedriges Drehmoment eingestellt ist.
 10. Setzen Sie alle Teile und Schrauben während der Montage locker zusammen. Erst wenn das Produkt fertig ist, sollten Sie die Schrauben vollständig festziehen.
 11. Überprüfen Sie regelmäßig und stellen Sie sicher, dass alle Schrauben und Anschlüsse ordnungsgemäß festgezogen sind.
 12. Bitte platzieren Sie keine Gegenstände, die die Tragfähigkeit überschreiten.
- Pflege und Wartung:
Reinigen Sie es nur mit einem feuchten Tuch und einem milden Reinigungsmittel. Verwenden Sie keine Bleichmittel oder Scheuermittel.

UK:Our product will be delivered to you in 2 packages. The delivery times of these 2 packages may differ, please be patient and thank you for your understanding.Please read these instructions fully before starting assembly:

Tools required: Phillips screwdriver(medium & large)

- 1.Check you have all the components and tools listed on the following pages.
- 2.Remove all fittings from the plastic bags and separate them into their groups.
- 3.Keep children and animals away from the work area, small parts could choke if swallowed.
- 4.Make sure you have enough space to layout the parts before starting.
- 5.During assembly do not stand or put weight on the product, this could cause damage.
- 6.Assemble the item as close to its final position (in the same room) as possible.
- 7.Assemble on a soft level surface to avoid damaging the unit or your floor.
- 8.Parts of the assembly will be easier with 2 people.
- 9.To reduce the likelihood of damaging your product please ensure that your power drill is set on a low torque setting.
- 10.Assemble all parts and bolts loosely during assembly, only once the product is complete should you fully tighten the bolts.
- 11.Regularly check and ensure That all bolts and fittings are tightend properly.
- 12.Please do not place items that exceed the load capacity.

Care and maintenance:

Only clean using a damp cloth and mild detergent, do no use bleach or abrasive cleaners.

FR:Notre produit vous sera livré en 2 paquets. Les délais de livraison de

Ces 2 forfaits peuvent différer, soyez patient et merci pour votre

Comprendre. Veuillez lire ces instructions complètement avant de commencer l'assemblage:

Outils requis: tournevis Phillips (moyen & grand)

1. Vérifiez que vous avez tous les composants et outils énumérés sur les pages suivantes.
2. Retirez tous les accessoires des sacs en plastique et séparez-les en groupes.
3. Gardez les enfants et les animaux loin de la zone de travail, les petites pièces pourraient s'étouffer

Si avalé.

4. Assurez-vous d'avoir suffisamment d'espace pour agencer les pièces avant de commencer.

5. Pendant l'assemblage ne tenez pas ou ne mettez pas de poids sur le produit, ceci pourrait causer

Dégâts.

6. Assemblez l'article le plus près possible de sa position finale (dans la même pièce).

7. Assemblez sur une surface plane douce pour éviter d'endommager l'unité ou votre plancher.

8. Les parties de l'assemblage seront plus faciles avec 2 personnes.

9. Pour réduire la probabilité d'endommager votre produit s'il vous plaît assurez-vous que votre

La perceuse électrique est réglée sur un réglage de couple faible.

10. Assemblez toutes les pièces et boulons librement pendant l'assemblage, seulement une fois le produit

Est complet si vous serrez complètement les boulons.

11. Vérifier régulièrement et s'assurer que tous les boulons et raccords sont bien serrés.

12. Veuillez ne pas placer les articles qui dépassent la capacité de charge.

Entretien et entretien:

Nettoyer uniquement à l'aide d'un chiffon humide et d'un détergent doux, ne pas utiliser d'eau de javel ou d'abrasif

Nettoyants.

IT:Il nostro prodotto sarà consegnato in 2 confezioni. I tempi di consegna di
Questi 2 pacchetti possono essere diversi, per favore siate pazienti e vi ringrazio
Comprensione. Leggere attentamente queste istruzioni prima di iniziare il montaggio:

Strumenti richiesti: cacciavite Phillips (medio e grande)

1. Controlla di avere tutti i componenti e gli strumenti elencati nelle pagine seguenti.
2. Togliere tutti gli accessori dai sacchetti di plastica e separarli in gruppi.
3. Tenere i bambini e gli animali lontani dal luogo di lavoro, piccole parti potrebbero soffocare
Se ingerito.

4. Assicuratevi di avere abbastanza spazio per sistemare le parti prima di iniziare.
5. Durante il montaggio non appoggiare il prodotto né pesarlo, ciò potrebbe causare
Danno.

6. Assemblare l'oggetto il più vicino possibile alla sua posizione finale (nella stessa stanza).
7. Assemblare su una superficie piana morbida per evitare danni all'unità o al pavimento.
8. Le parti dell'assemblea saranno più facili con 2 persone.
9. Per ridurre la probabilità di danneggiare il prodotto, si assicuri che il

Il trapano di potenza è regolato su una regolazione di coppia bassa.

10. Montare tutte le parti e i bulloni liberamente durante l'assemblaggio, solo una volta il
prodotto

È completa se si chiude completamente i bulloni.

11. Controllare regolarmente e assicurarsi che tutti i bulloni e gli accessori siano ben stretti.
12. Non collocare oggetti che superino la capacità di carico.

Cura e manutenzione:

Pulire solo con un panno umido e un detergente leggero, non usare candeggina o abrasivo

Detergenti.

ES:Nuestro producto le será entregado en 2 paquetes. Los plazos de entrega de Estos 2 paquetes pueden diferir, por favor tenga paciencia y gracias por su Entendimiento. Por favor, lea estas instrucciones antes de comenzar el montaje:

Herramientas necesarias: destornautomático Phillips (mediano y grande)

1. Compruebe que tiene todos los componentes y herramientas listados en las siguientes páginas.
2. Retire todos los accesorios de las bolsas de plástico y separarlos en sus grupos.
3. Mantenga a los niños y los animales lejos de la zona de trabajo, las partes pequeñas se pueden asfixi.

En caso de ingestión.

4. Asegúrese de tener suficiente espacio para diseñar las piezas antes de empezar.
5. Durante el montaje no se ponga de pie o poner peso sobre el producto, esto podría causar

Daños.

6. Montar el objeto lo más cerca posible de su posición final (en la misma habitación).
7. Montar sobre una superficie suave para evitar dañar la unidad o el suelo.
8. Las partes de la Asamblea será más fácil con 2 personas.
9. Para reducir la probabilidad de dañar su producto por favor asegúrese de que su La perforadora de potencia se ajusta con un par de torsión bajo.
10. Montar todas las piezas y pernos sueldurante el montaje, sólo una vez que el producto Es completa en caso de que plenamente apretar los tornillos.
11. Comprobar periódicamente y asegurarse de que todos los pernos y accesorios se aprietan correctamente.
12. Por favor no coloque artículos que excedan la capacidad de carga.

Cuidado y mantenimiento:

Sólo limpie con un paño húmedo y detergente suave, no utilice blanqueador ni abrasivo Limpiadores.

Assembly Instruction / Montageanleitung

ITEM:N890P388285+ N890P388287

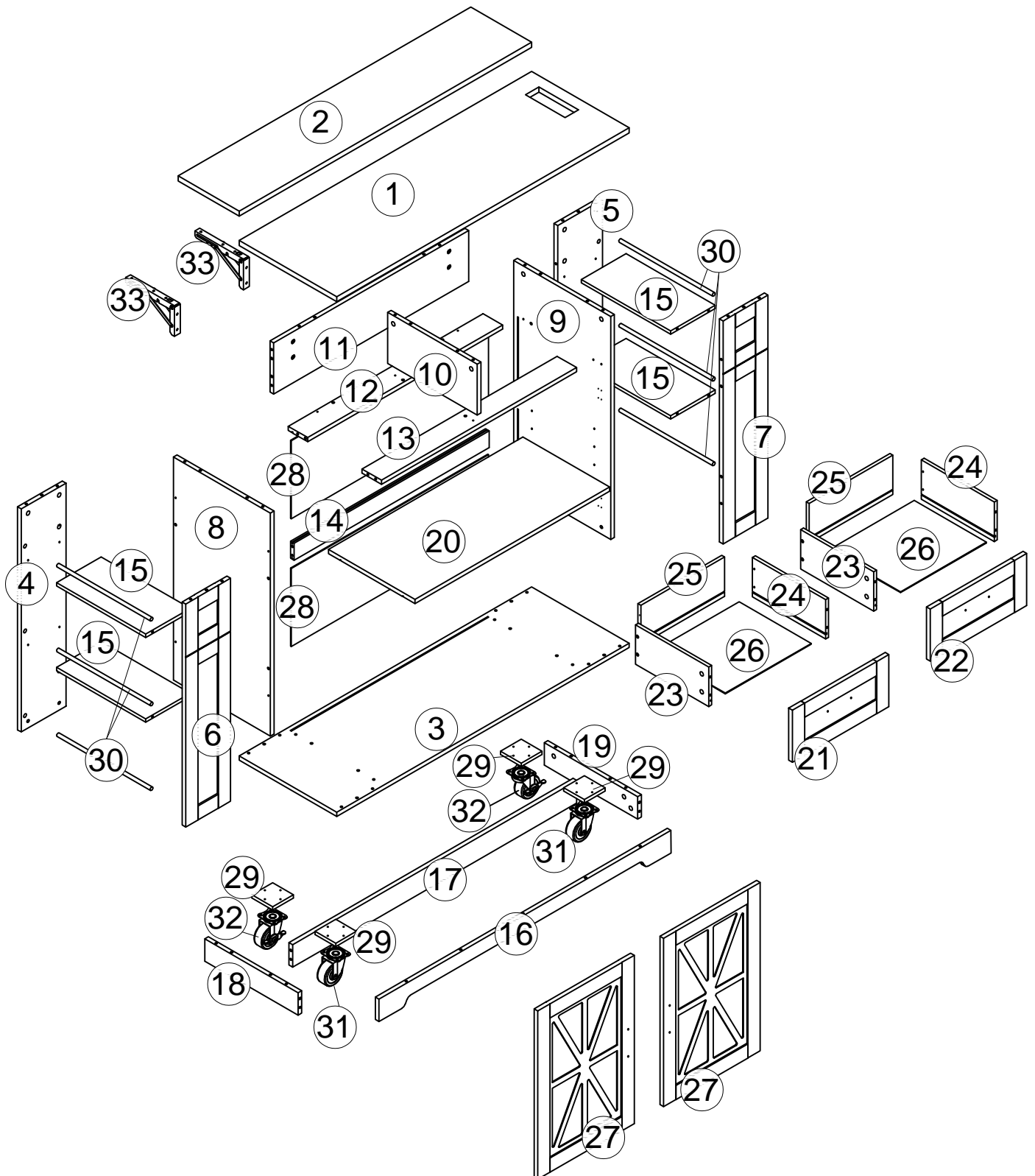

Teileliste / Part List / Liste des pièces / Elenco delle parti / Lista de piezas

Please check you have all the panels listed below

/Bitte überprüfen Sie, ob alle unten aufgeführten Panels vorhanden sind

Note: The quantities below are the correct amount to complete the assembly. In some cases more fittings may be supplied than are required. / Hinweis: Die unten angegebenen Mengen sind die richtigen Mengen, um die Montage abzuschließen. In manchen Fällen können mehr Armaturen geliefert werden, als erforderlich sind.

N890P388285

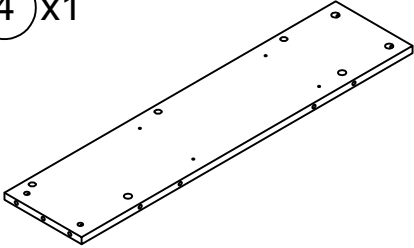
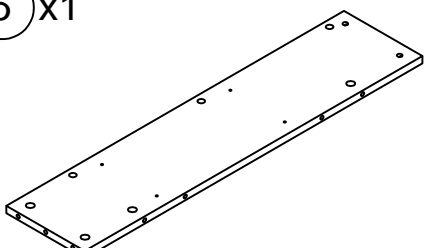
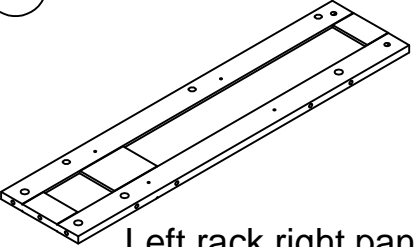
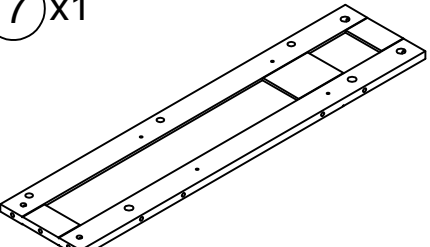
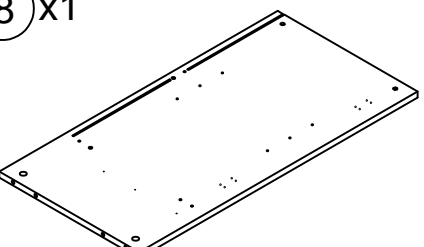
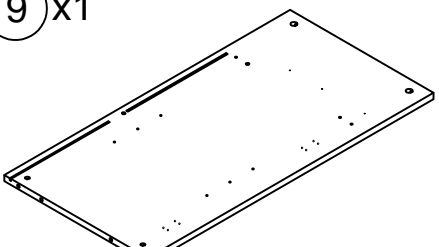
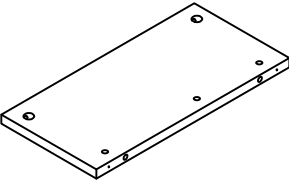
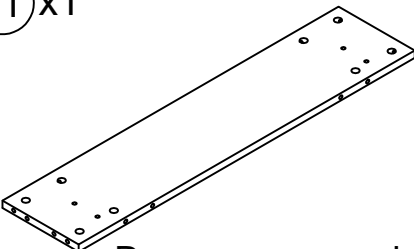
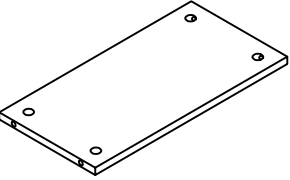
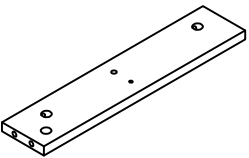
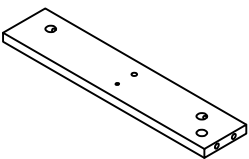
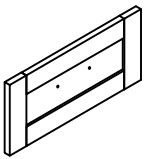
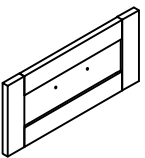
<p>④ x1</p>  <p>Left rack left panel</p>	<p>⑤ x1</p>  <p>Right rack right panel</p>	<p>⑥ x1</p>  <p>Left rack right panel</p>
<p>⑦ x1</p>  <p>Right rack left panel</p>	<p>⑧ x1</p>  <p>Left panel</p>	<p>⑨ x1</p>  <p>Right panel</p>
<p>⑩ x1</p>  <p>Middle partition</p>	<p>⑪ x1</p>  <p>Rear upper crossbar</p>	<p>⑮ x4</p>  <p>Rack shelf</p>
<p>⑱ x1</p>  <p>Left apron</p>	<p>⑲ x1</p>  <p>Right apron</p>	<p>⑳ x1</p>  <p>Left drawer front</p>
<p>㉒ x1</p>  <p>Right drawer front</p>		

Teileliste / Part List / Liste des pièces /
Elenco delle parti / Lista de piezas

Please check you have all the panels listed below
/Bitte überprüfen Sie, ob alle unten aufgeführten Panels vorhanden sind

Note: The quantities below are the correct amount to complete the assembly. In some cases more fittings may be supplied than are required. / Hinweis: Die unten angegebenen Mengen sind die richtigen Mengen, um die Montage abzuschließen. In manchen Fällen können mehr Armaturen geliefert werden, als erforderlich sind.

N890P388285

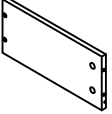
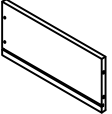
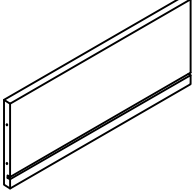
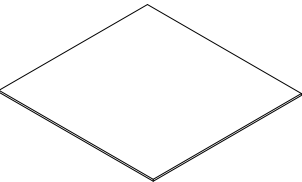
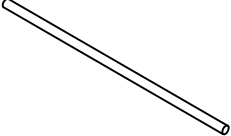
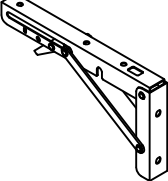
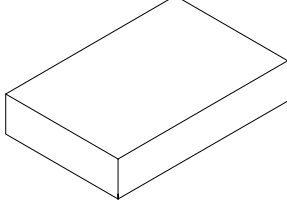
<p>23 x2</p>  <p>Drawer left panel</p>	<p>24 x1</p>  <p>Drawer right panel</p>	<p>25 x2</p>  <p>Drawer rear panel</p>
<p>26 x2</p>  <p>Drawer bottom panel</p>	<p>30 x6</p>  <p>Rail</p>	<p>33 x2</p>  <p>Folding bracket</p>
 <p>Hardware kit</p>		



Teileliste / Part List / Liste des pièces / Elenco delle parti / Lista de piezas

Please check you have all the panels listed below

/Bitte überprüfen Sie, ob alle unten aufgeführten Panels vorhanden sind

Note: The quantities below are the correct amount to complete the assembly. In some cases more fittings may be supplied than are required. / Hinweis: Die unten angegebenen Mengen sind die richtigen Mengen, um die Montage abzuschließen. In manchen Fällen können mehr Armaturen geliefert werden, als erforderlich sind.

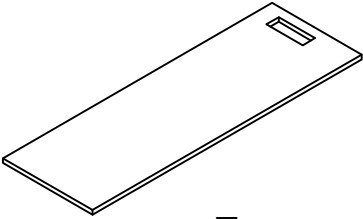
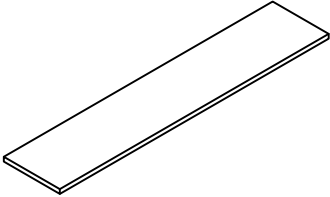
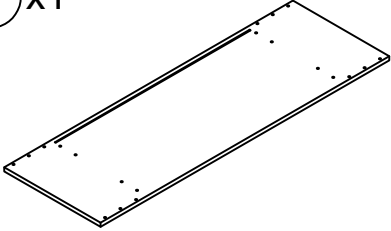
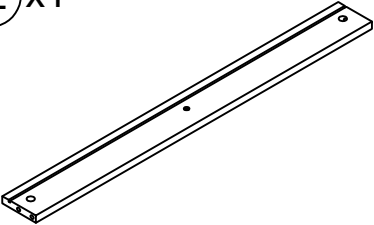
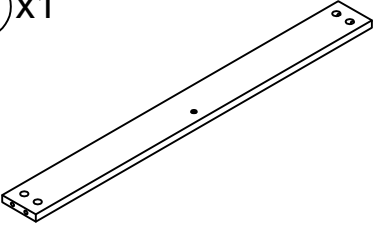
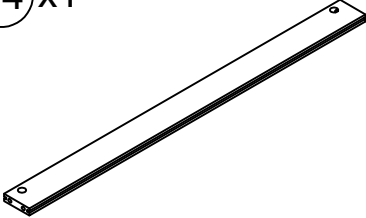
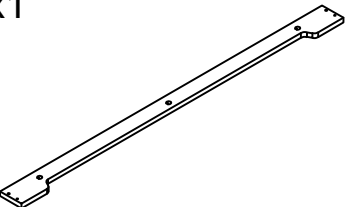
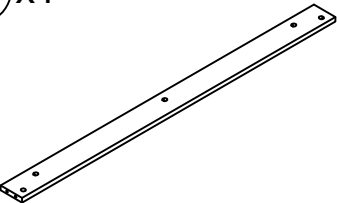
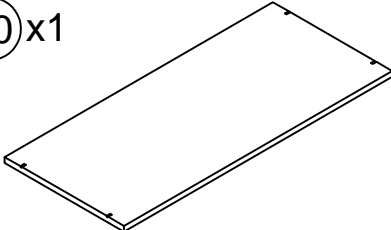
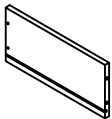
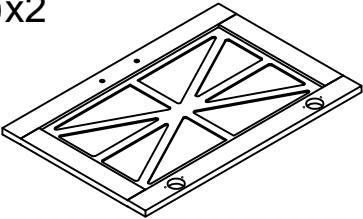
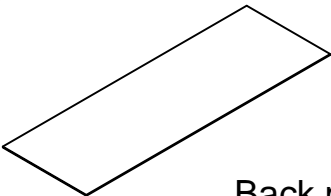
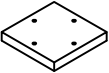
N890P388287

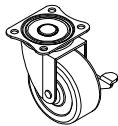
<p>① x1</p>  <p>Top panel</p>	<p>② x1</p>  <p>Folding top panel</p>	<p>③ x1</p>  <p>Bottom panel</p>
<p>⑫ x1</p>  <p>Rear middle crossbar</p>	<p>⑬ x1</p>  <p>Front crossbar</p>	<p>⑭ x1</p>  <p>Rear lower crossbar</p>
<p>⑯ x1</p>  <p>Front apron</p>	<p>⑰ x1</p>  <p>Rear apron</p>	<p>⑳ x1</p>  <p>Adjustable shelf</p>
<p>㉔ x1</p>  <p>Drawer right panel</p>	<p>㉗ x2</p>  <p>Door</p>	<p>㉘ x2</p>  <p>Back panel</p>
<p>㉙ x4</p>  <p>Brack</p>	<p>㉛ x2</p>  <p>Castor without brake</p>	<p>㉜ x2</p>  <p>Castor with brake</p>













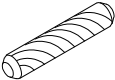
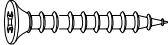



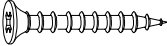
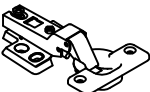

Hardwareliste / Hardware List / Liste de matériel / Elenco hardware / Lista de hardware ITEM:N890P388285+ N890P388287

Please check you have all the panels listed below

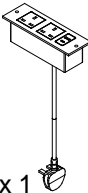
/Bitte überprüfen Sie, ob alle unten aufgeführten Panels vorhanden sind

Note: The quantities below are the correct amount to complete the assembly. In some cases more fittings may be supplied than are required. / Hinweis: Die unten angegebenen Mengen sind die richtigen Mengen, um die Montage abzuschließen. In manchen Fällen können mehr Armaturen geliefert werden, als erforderlich sind.

N890P388285+ N890P388287

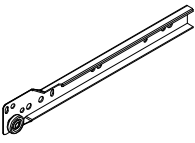
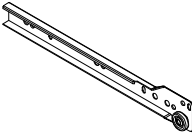
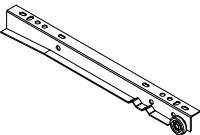
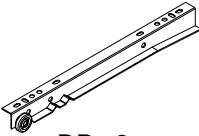
 A x 74 eccentric rod	 B x 74 eccentric rod gear	 8x30mm C x 54 Dowels	 4x35 D x 10 Screws	 3.5x14 E x 48 Screws	 F x 12
 6x45mm G x 12 Bolts	 6x15mm H x 4 Bolts	 I x 4 Handle	 4x18 J x 4 Bolts	 K x 4 Shelf support	 4x20 L x 16 Screws
 M x 4 Hinge	 3.5x14mm N x 2 Screws	 O x 1 Slide	 4x8 P x 4 Bolts	 Q x 12 panel hook	 R x 1 Tool
 4x14mm S x 22 Screw	 3x14mm T x 12 Screws	 CL x2 Slide	 CR x2 Slide	 DL x2 Slide	 DR x2 Slide

Assembly Instruction Montageanleitung

ITEM:N890P388285+ N890P388287

Step 1

X2

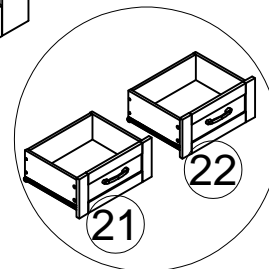
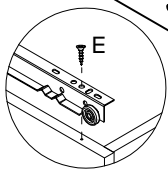
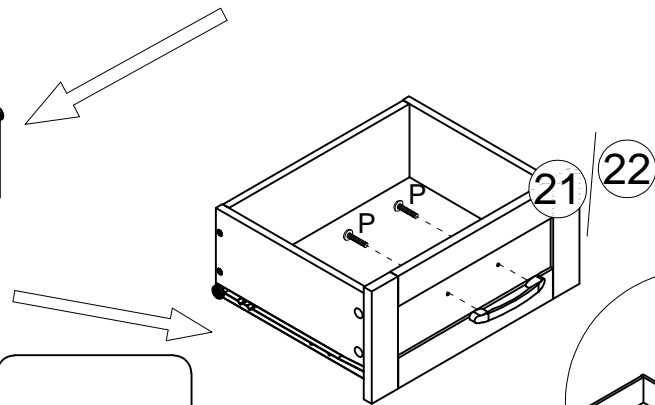
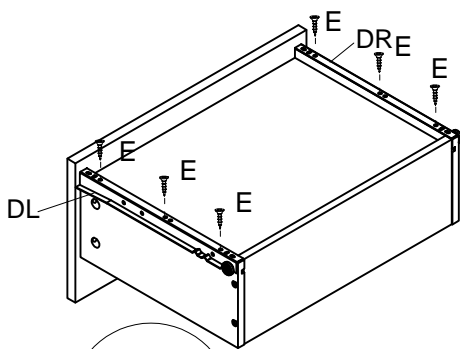
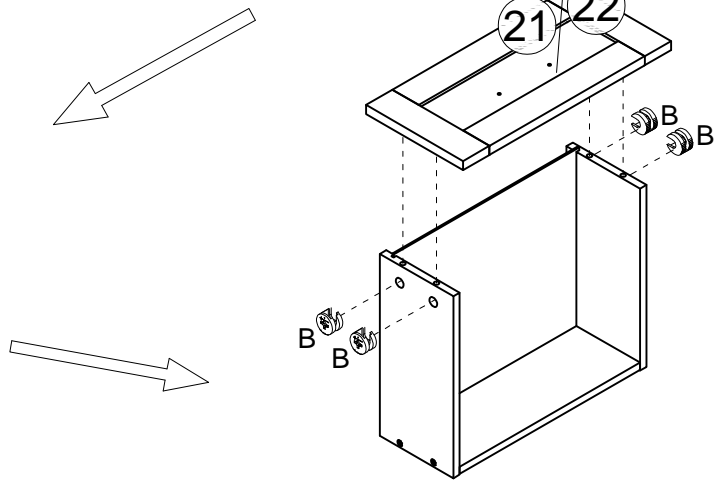
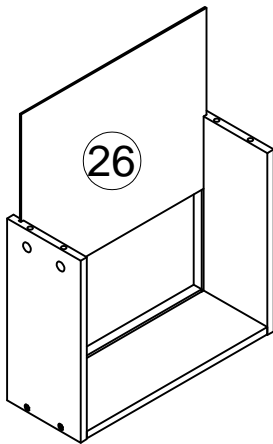
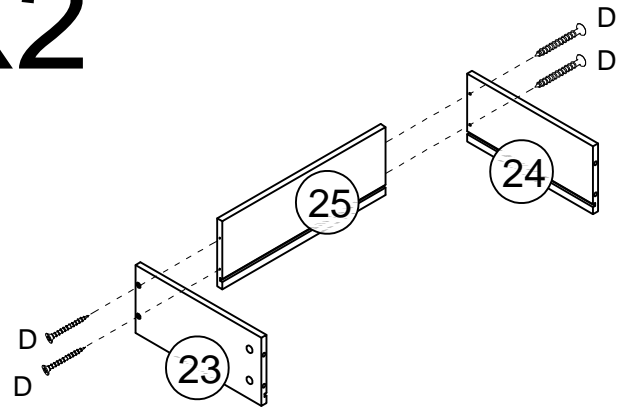
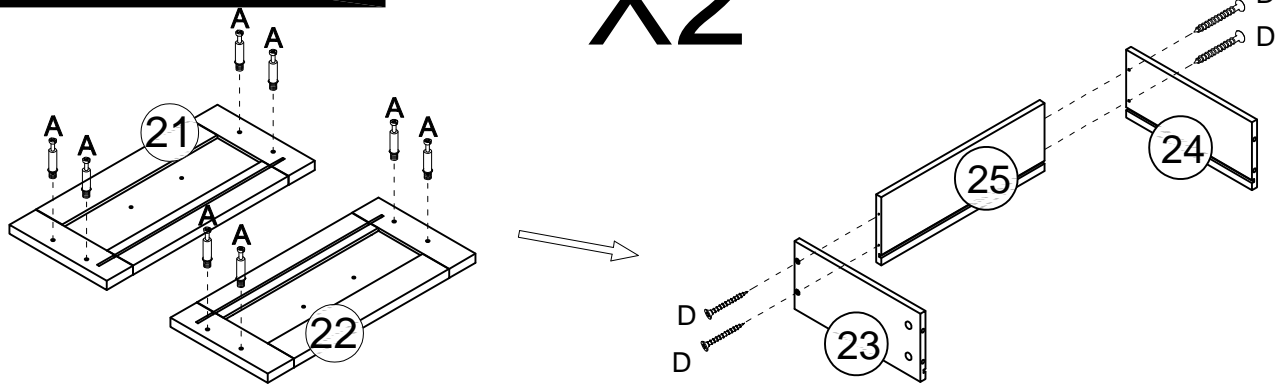

Handle I x 2	Bolts P x 4				
eccentric rod A x 8	eccentric rod gear B x 8	Screws D x 8	Screws E x 12	Slide DL x 2	Slide DR x 2

Assembly Instruction Montageanleitung

ITEM:N890P388285+ N890P388287

Step 2

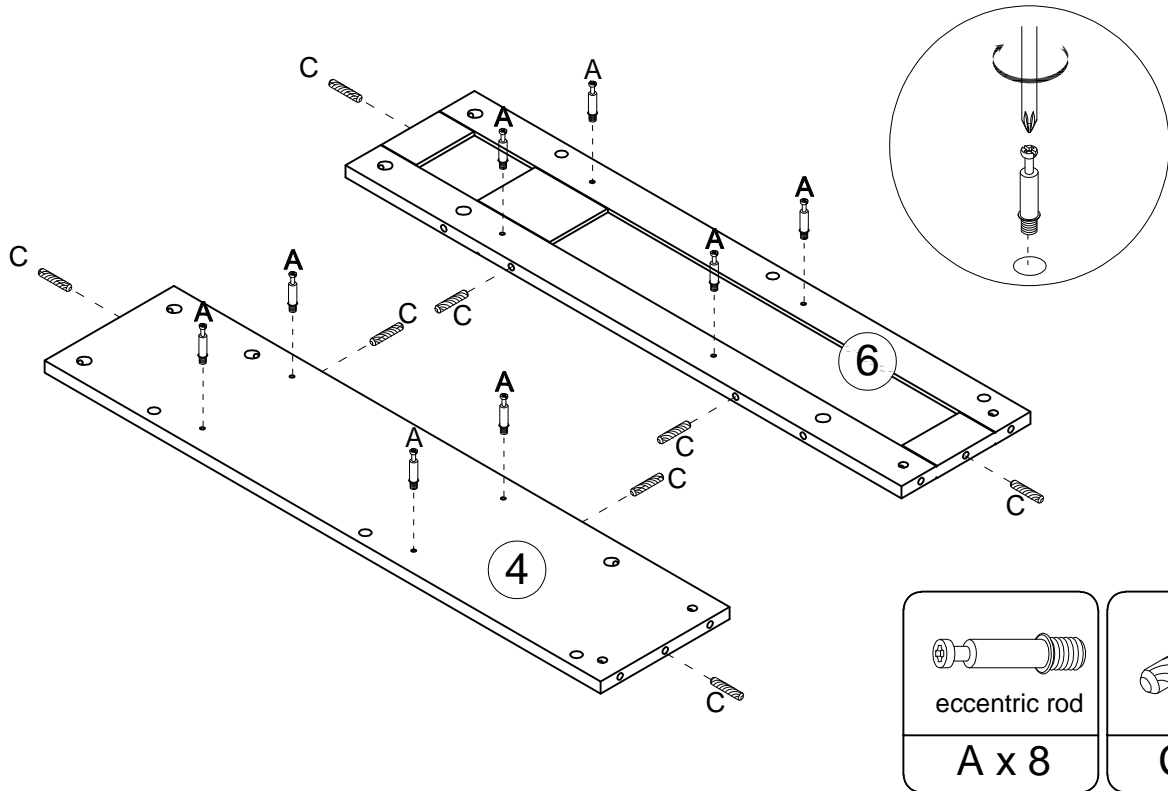

Step 3

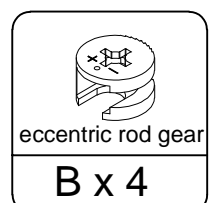
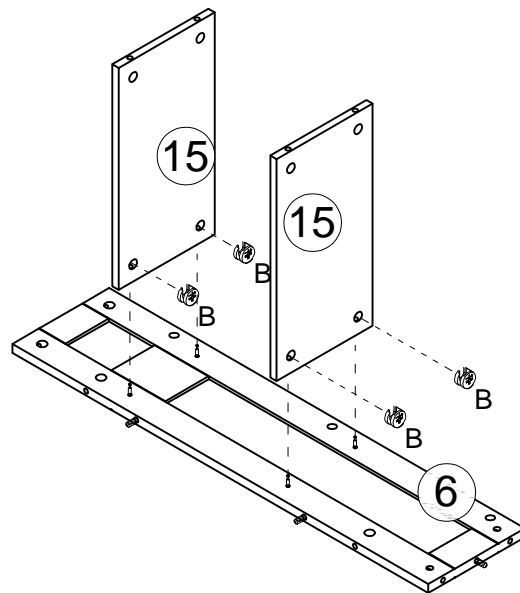

Assembly Instruction Montageanleitung

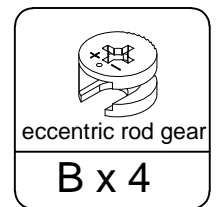
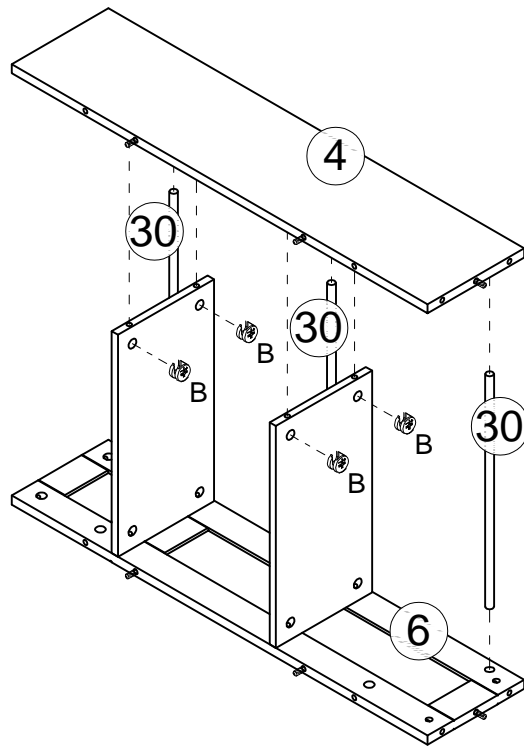

ITEM:N890P388285+ N890P388287

Step 4

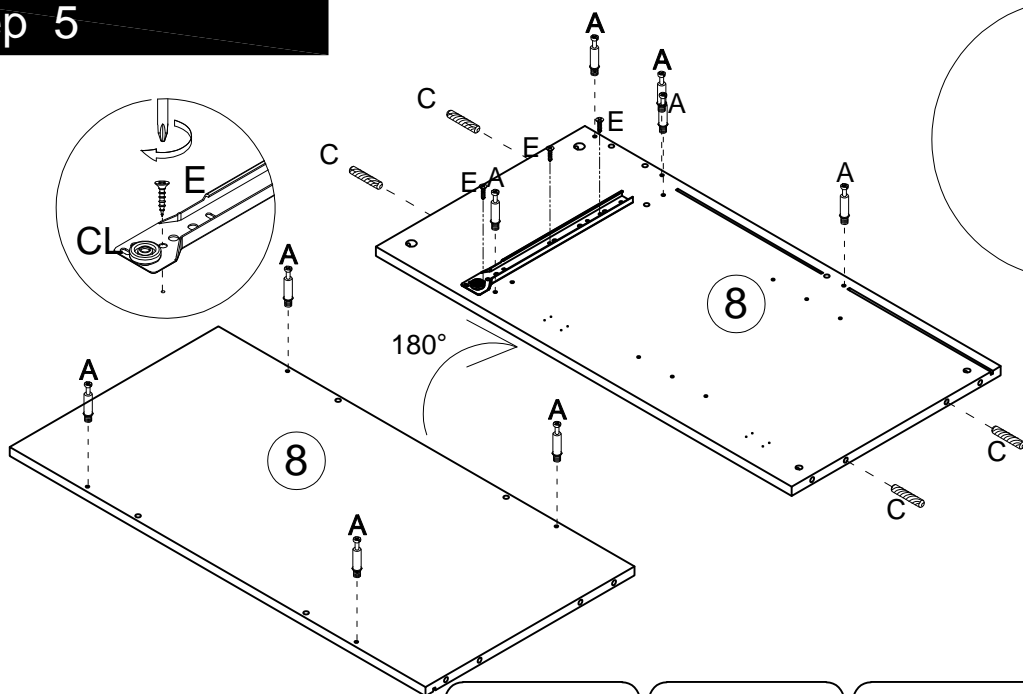

Step 5

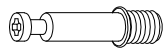
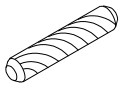

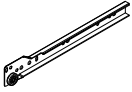
			
eccentric rod	Dowels	Screws	Slide
A x 9	C x 4	E x 3	CL x 1

Assembly Instruction Montageanleitung

ITEM:N890P388285+ N890P388287

Step 6

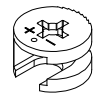
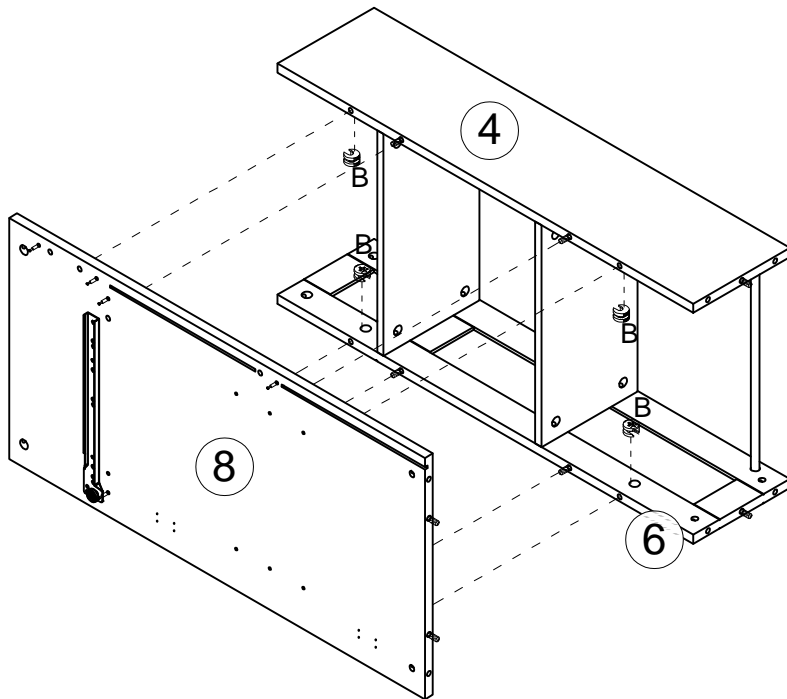

eccentric rod gear

B x 4

Step 7

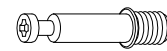
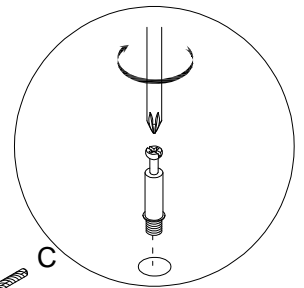
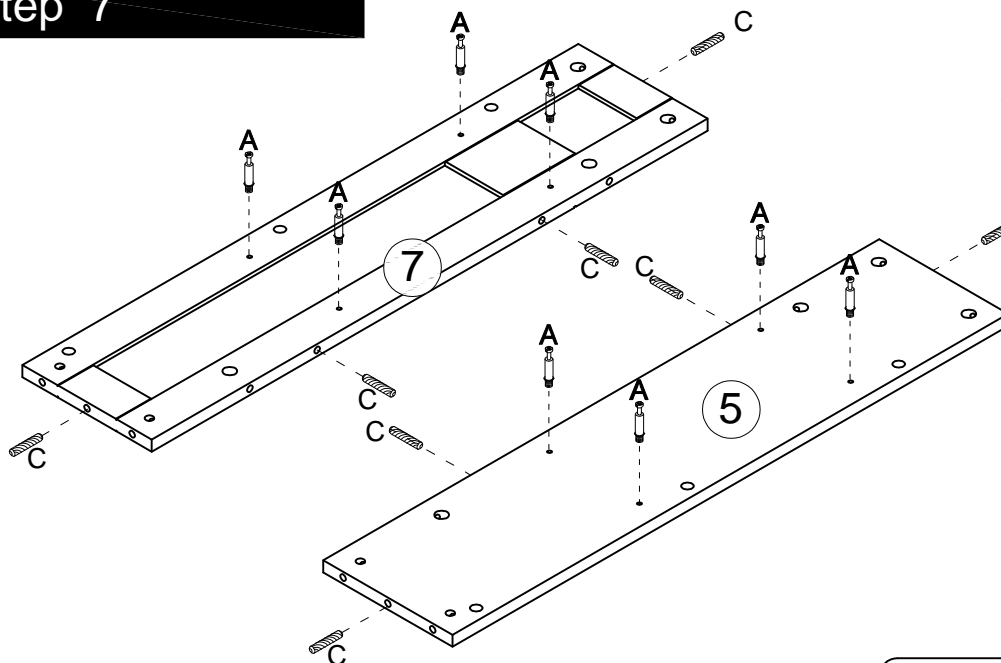

eccentric rod

A x 8

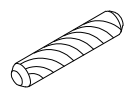

Dowels

C x 8

Assembly Instruction Montageanleitung

ITEM:N890P388285+ N890P388287

Step 8

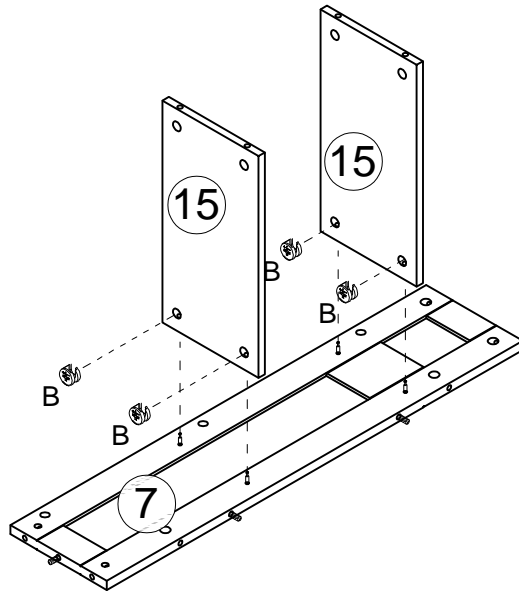

eccentric rod gear

B x 4

Step 9

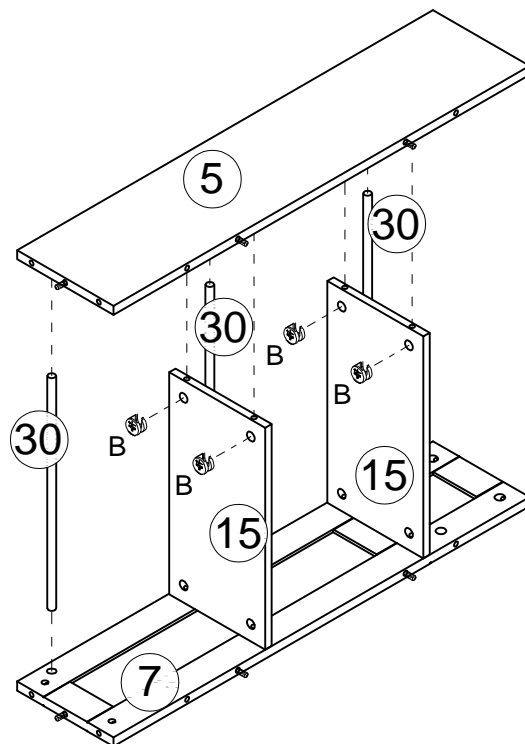

eccentric rod gear



B x 4

Assembly Instruction Montageanleitung

ITEM:N890P388285+ N890P388287

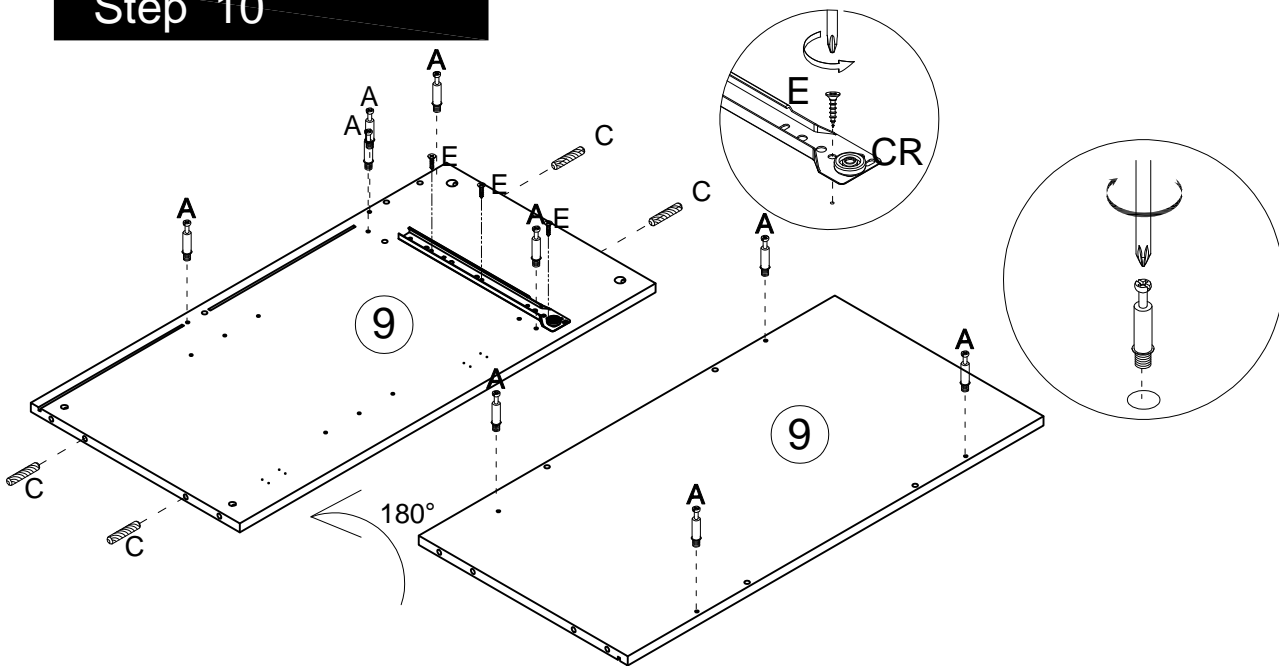
Step 10

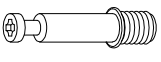
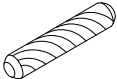

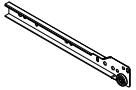
 eccentric rod	 Dowels	 Screws	 Slide
A x 9	C x 4	E x 3	CR x 1

Step 11

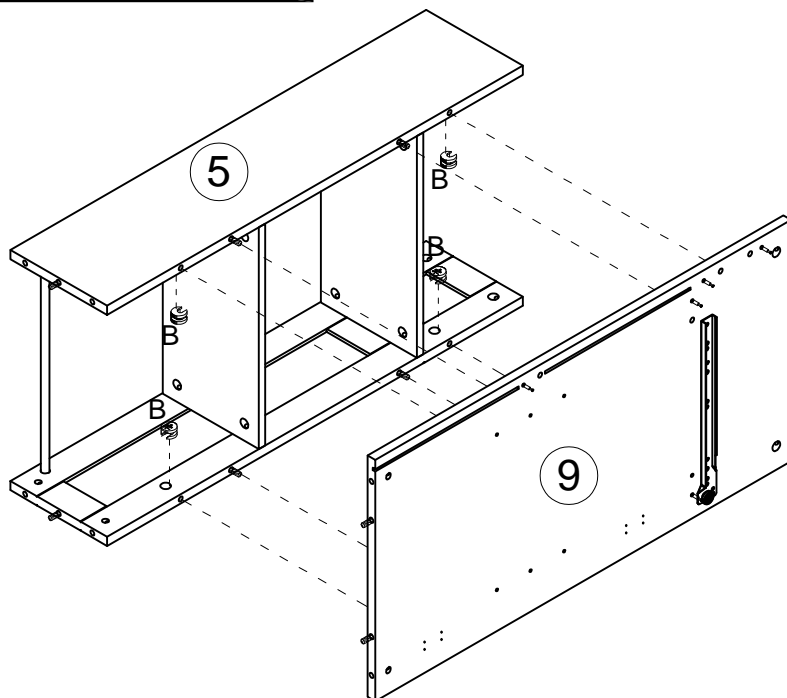

 eccentric rod gear
B x 4

Assembly Instruction Montageanleitung

ITEM:N890P388285+ N890P388287

Step 12

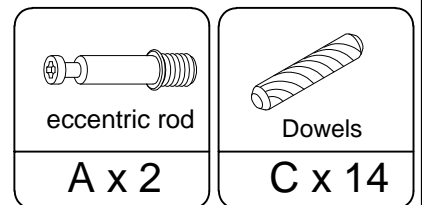
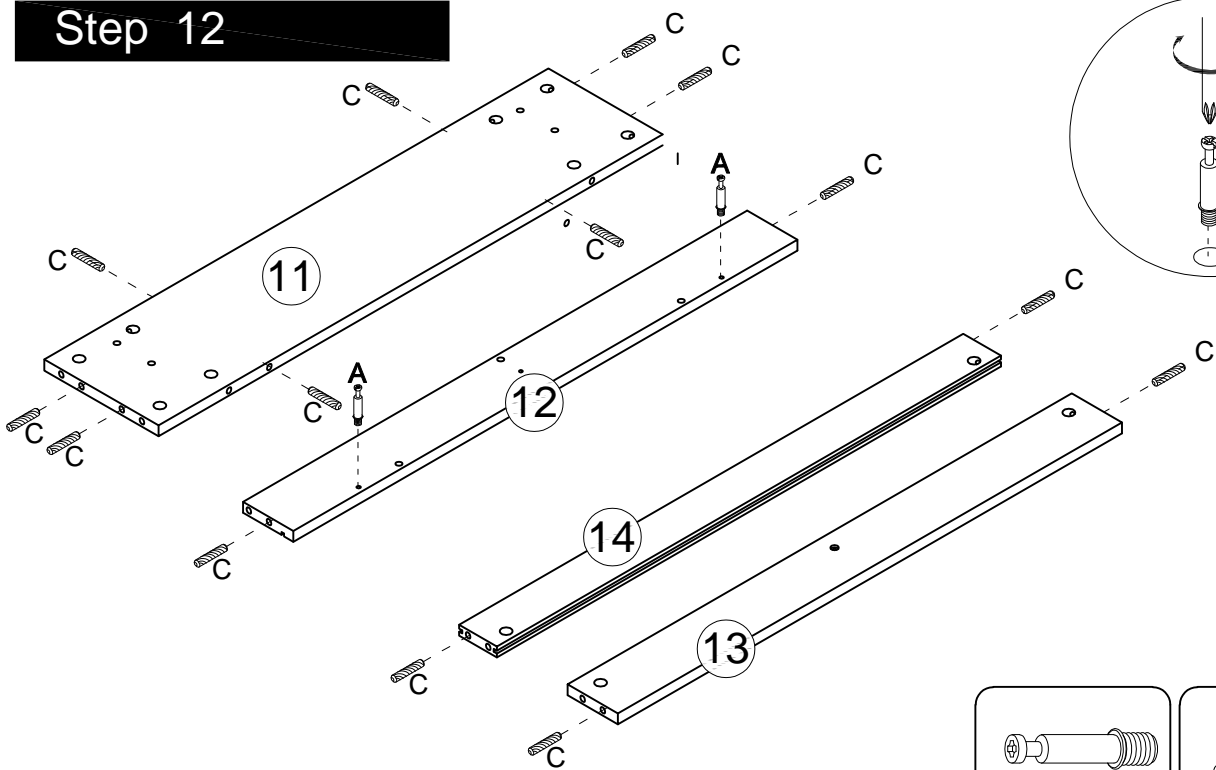

Step 13

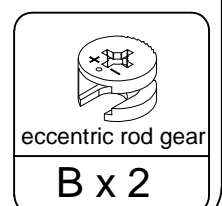
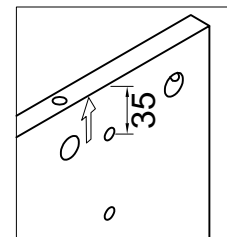
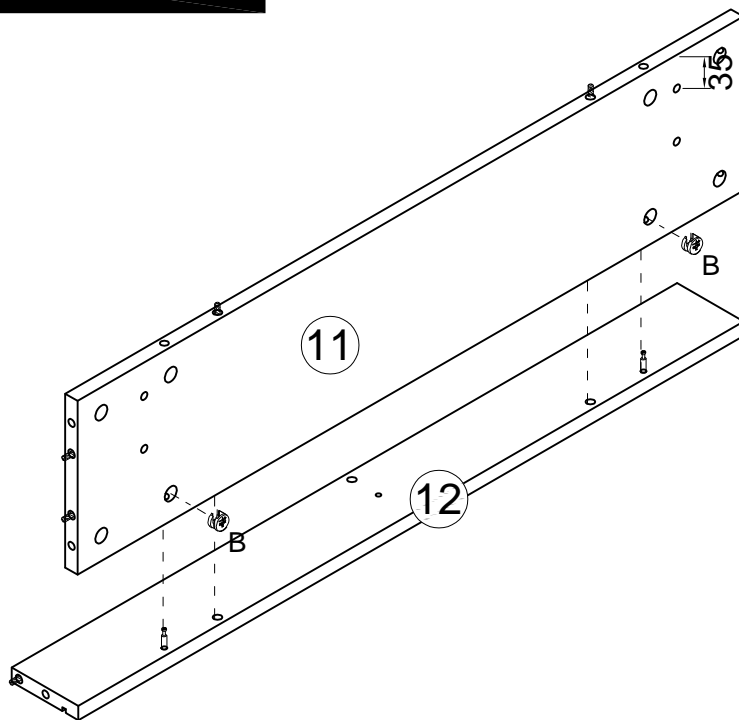

Assembly Instruction Montageanleitung

ITEM:N890P388285+ N890P388287

Step 14

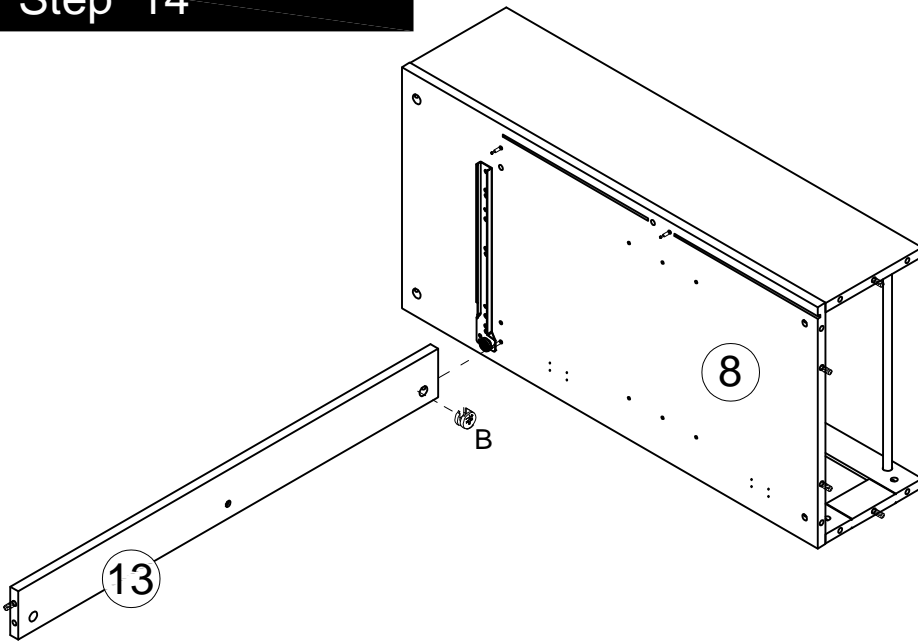

eccentric rod gear

B x 1

Step 15

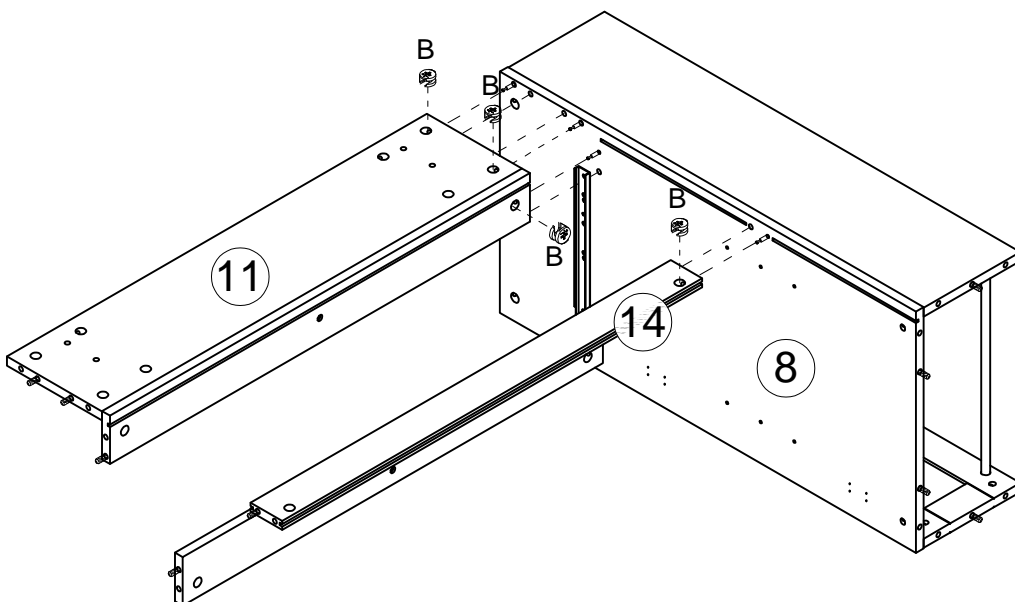

eccentric rod gear

B x 4

Assembly Instruction Montageanleitung

ITEM:N890P388285+ N890P388287

Step 16

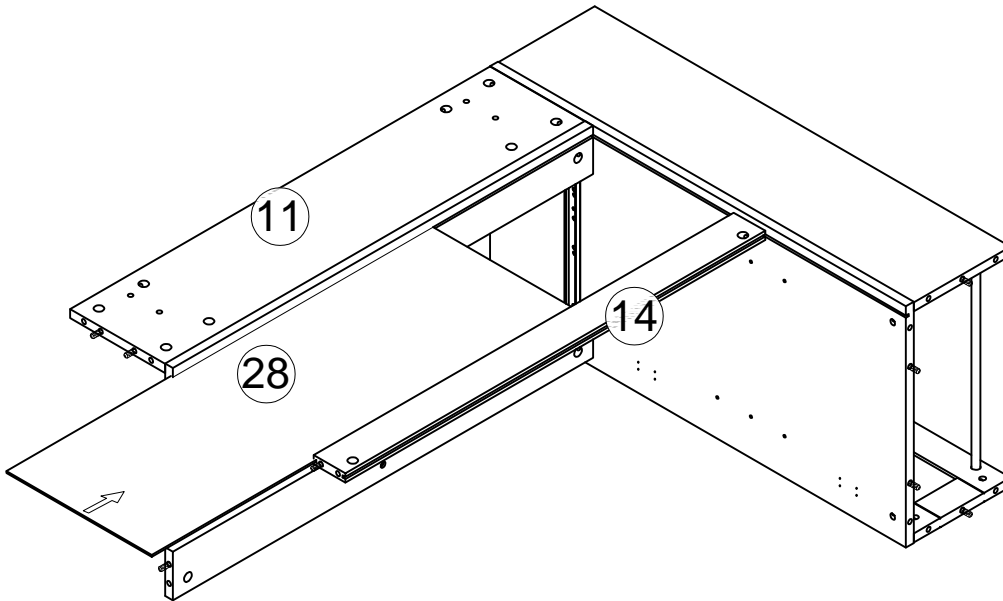

Step 17

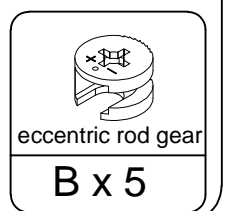
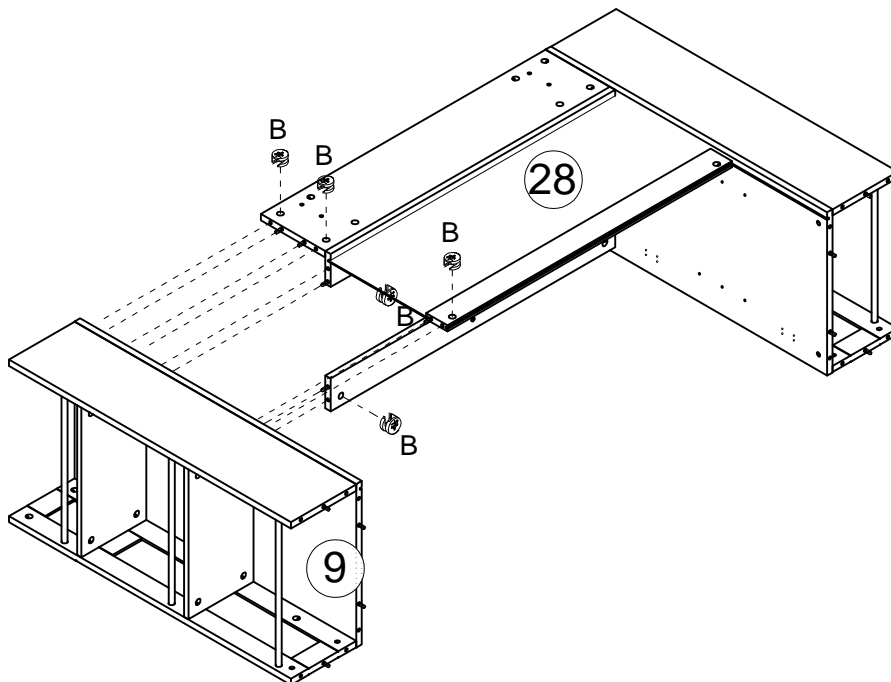

Assembly Instruction Montageanleitung

ITEM:N890P388285+ N890P388287

Step 18

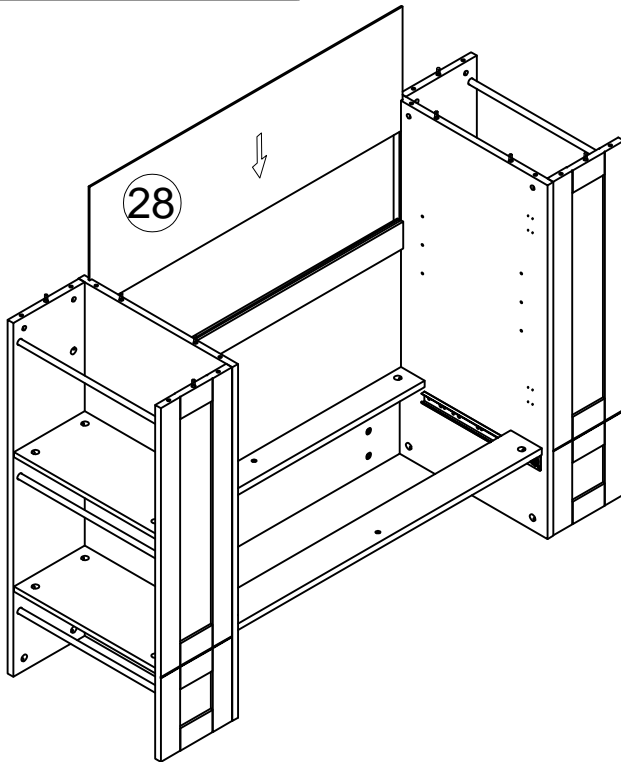

Step 19

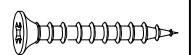
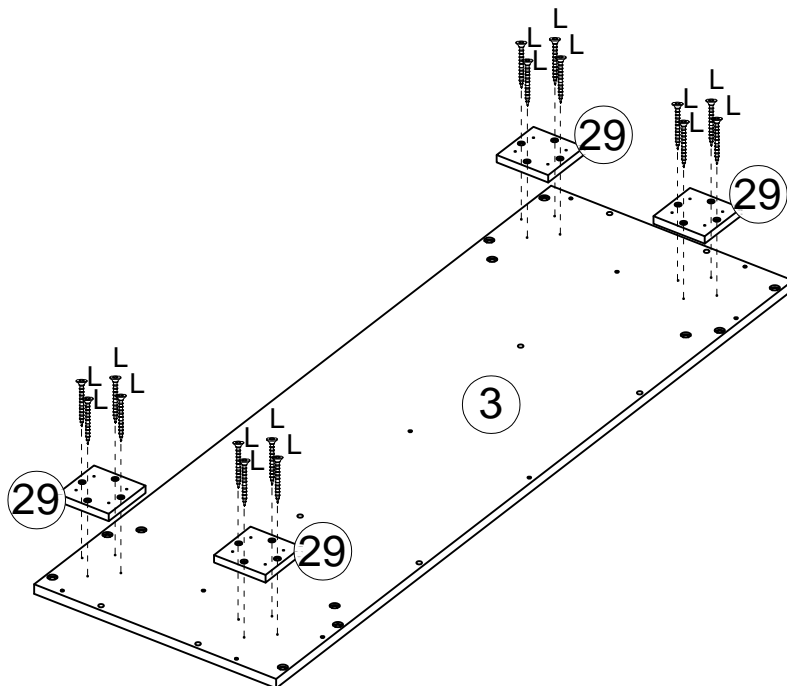

Screws

L x 16

Assembly Instruction Montageanleitung

ITEM:N890P388285+ N890P388287

Step 20

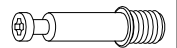
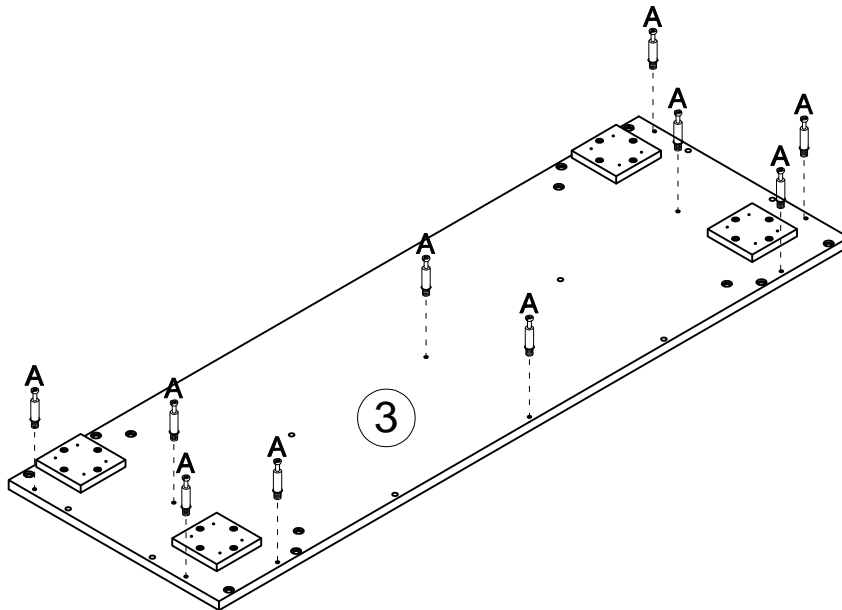

eccentric rod

A x 10

Step 21

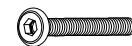
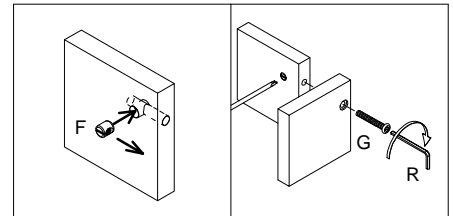
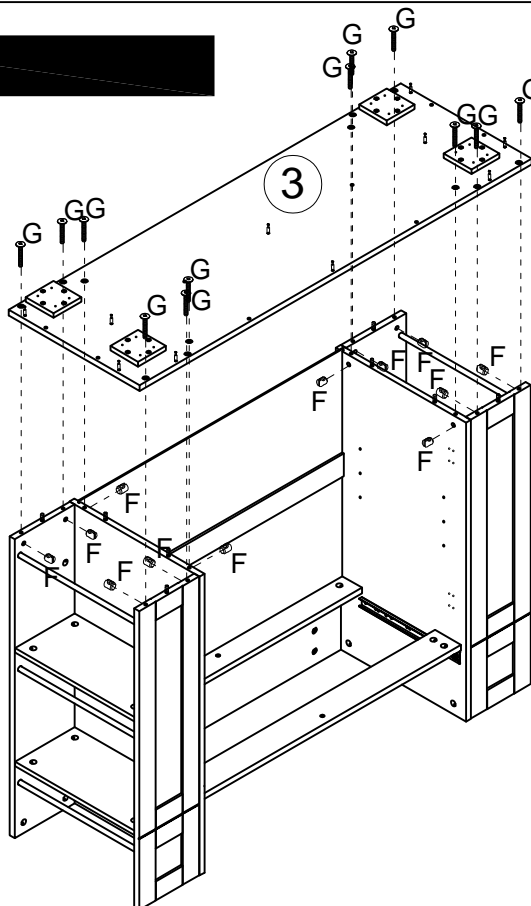

Bolts

G x 12



F x 12

Assembly Instruction Montageanleitung

ITEM:N890P388285+ N890P388287

Step 22

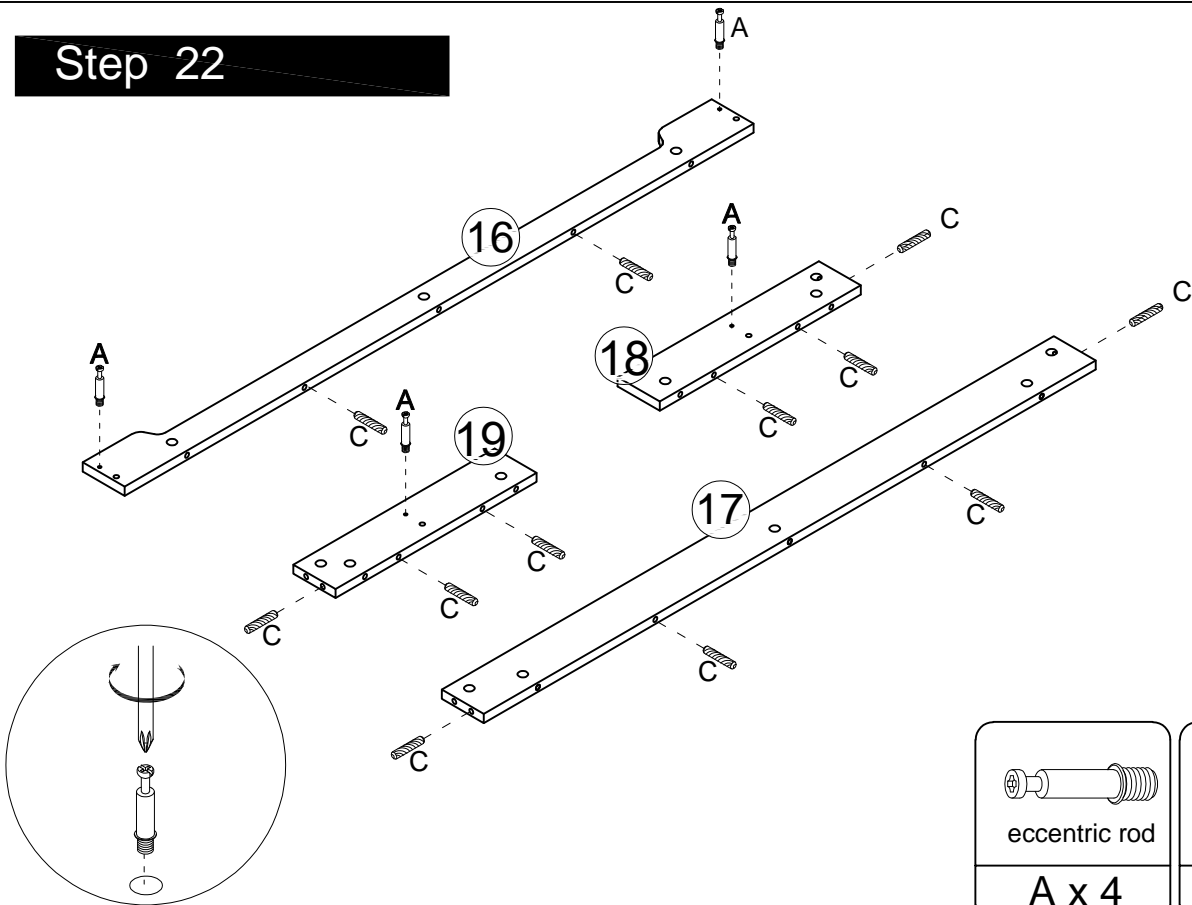

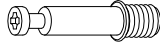
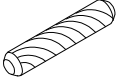
 eccentric rod	 Dowels
A x 4	C x 12

Step 23

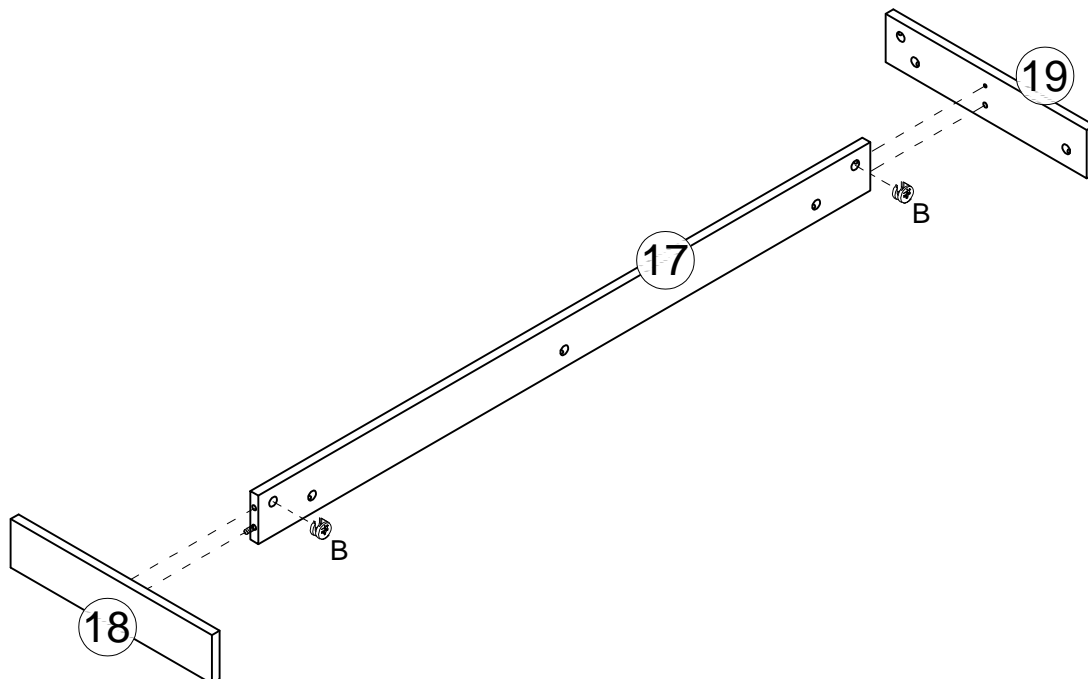

 eccentric rod gear
B x 2

Assembly Instruction Montageanleitung

ITEM:N890P388285+ N890P388287

Step 24

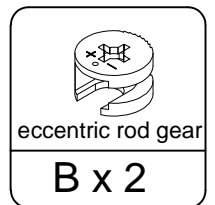
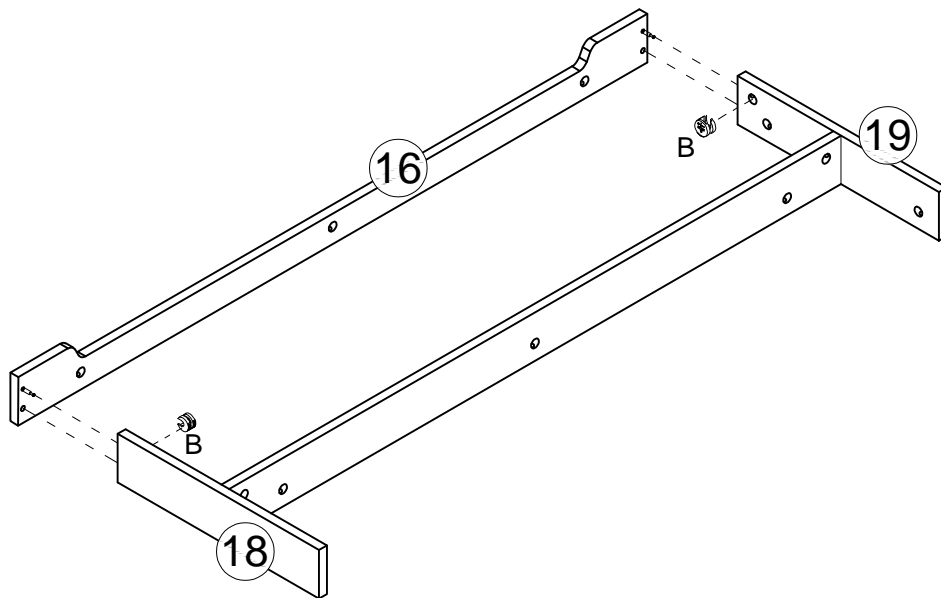

Step 25

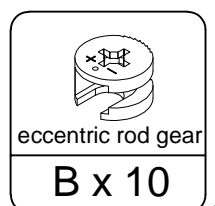
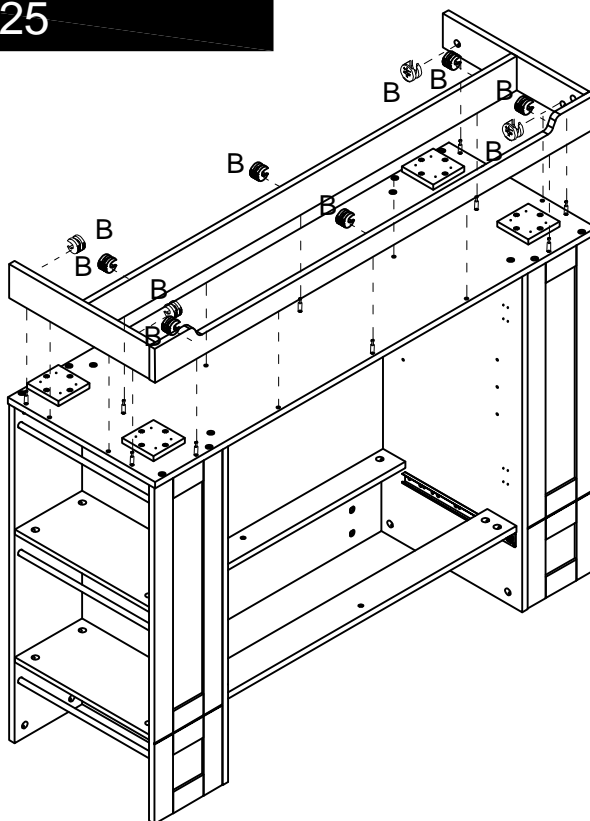

Assembly Instruction Montageanleitung

ITEM:N890P388285+ N890P388287

Step 26

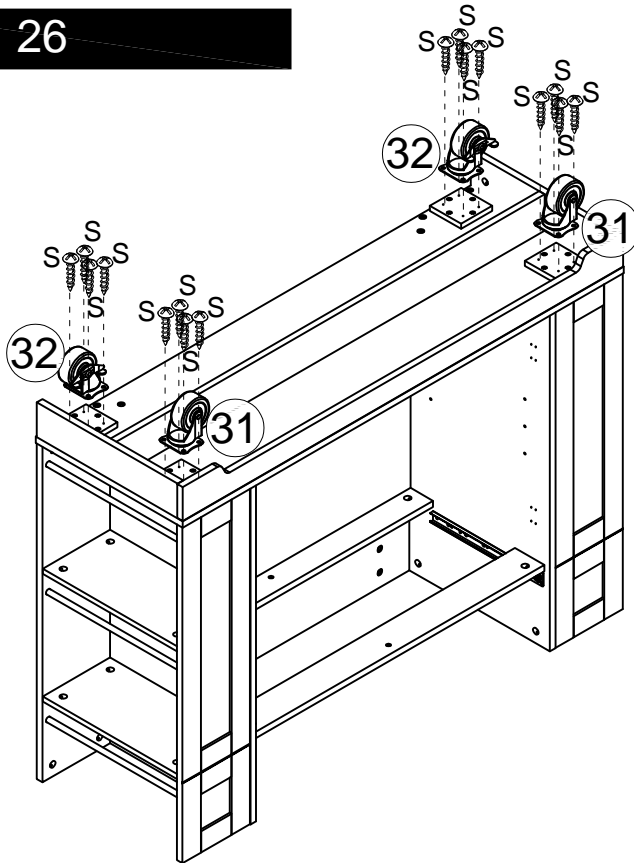

Screw
S x 16

Step 27

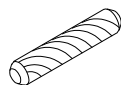
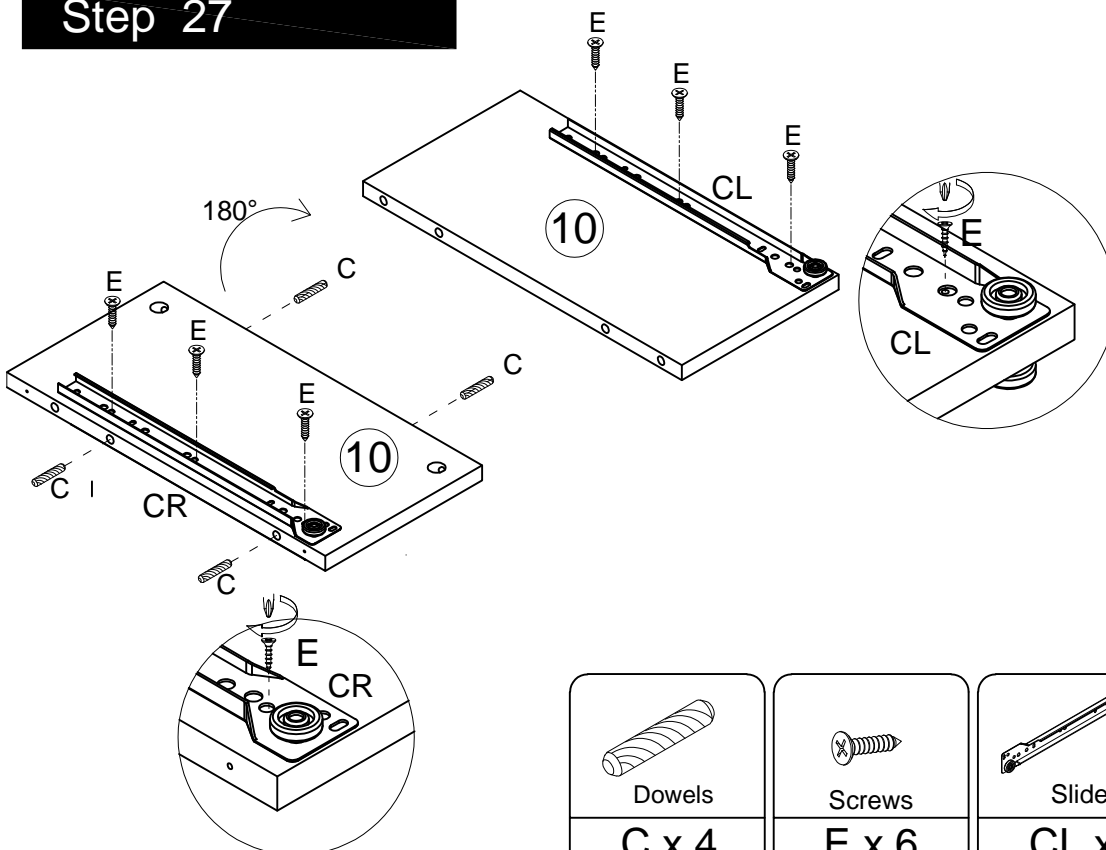

Dowels

C x 4



Screws

E x 6

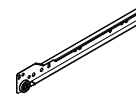

Slide

CL x 1

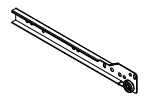

Slide

CR x 1

Assembly Instruction Montageanleitung

ITEM:N890P388285+ N890P388287

Step 28

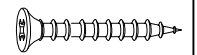
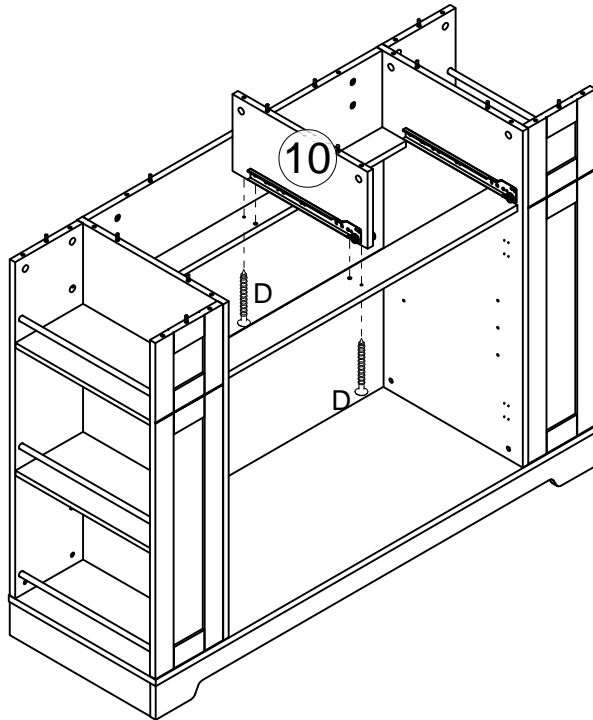

Screws

D x 2

Step 29

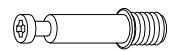
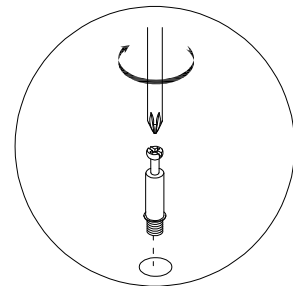
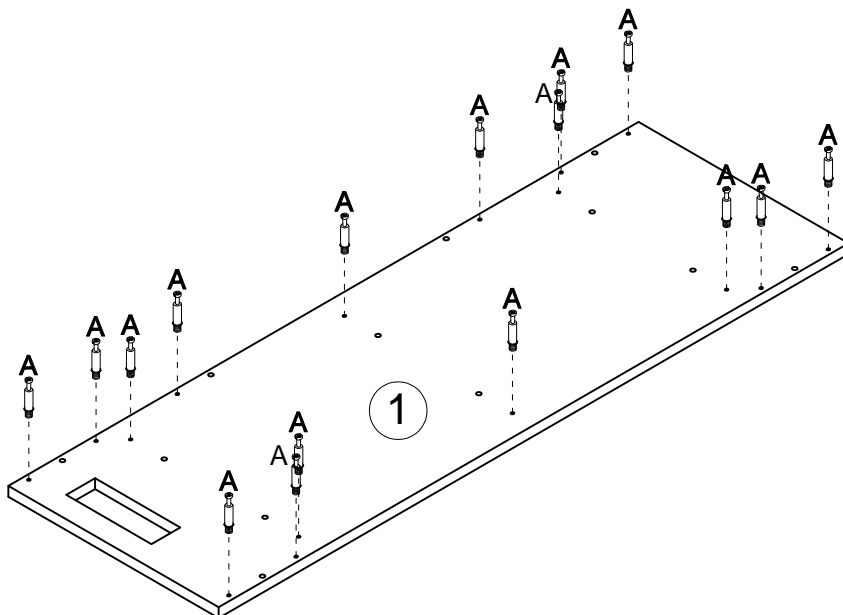

eccentric rod

A x 16

Assembly Instruction Montageanleitung

ITEM:N890P388285+ N890P388287

Step 30

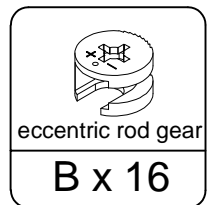
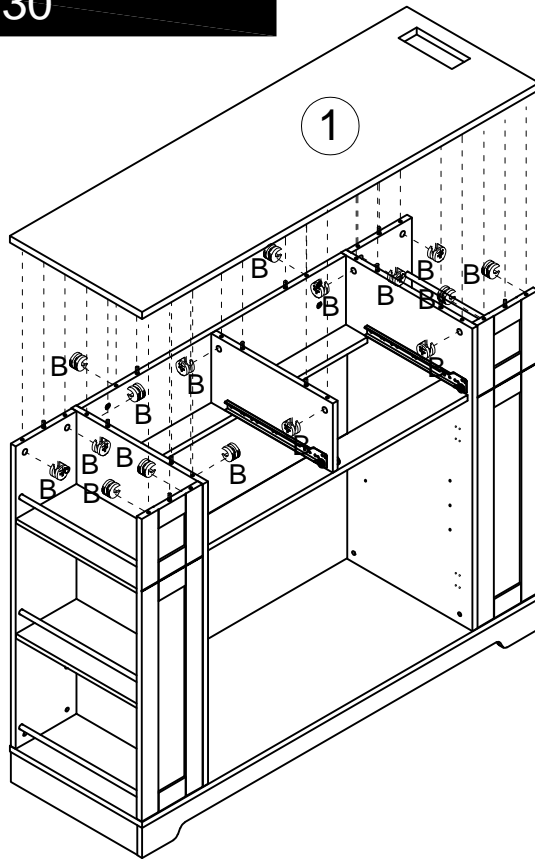

Step 31

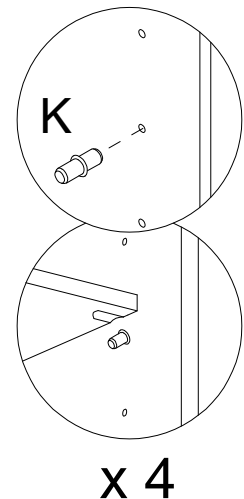
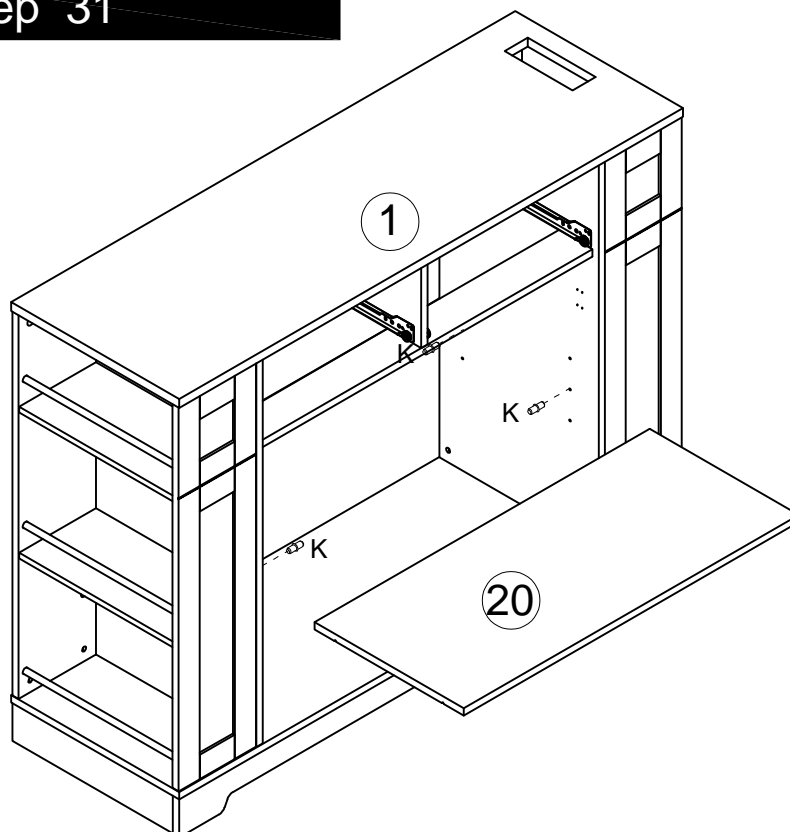

x 4

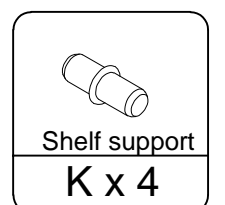

Assembly Instruction Montageanleitung

ITEM:N890P388285+ N890P388287

Step 32

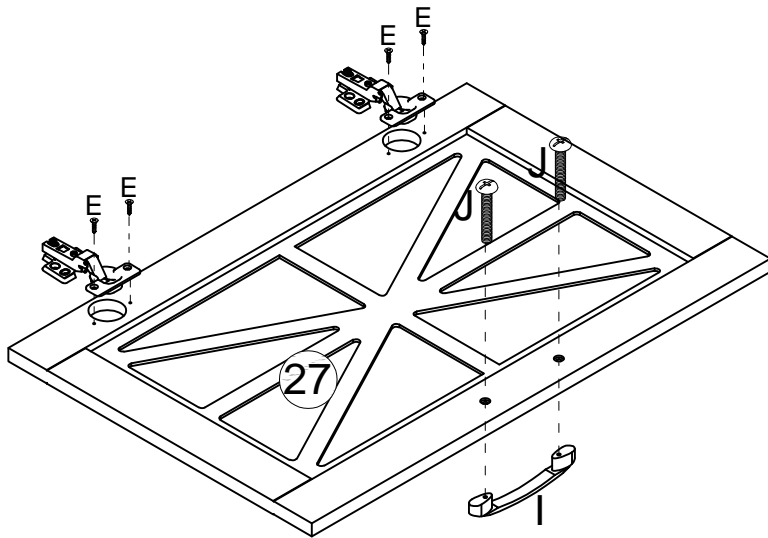

x2



Hinge
M x 4



Screws
E x 8



Handle
I x 2



Bolts
J x 4

Step 33

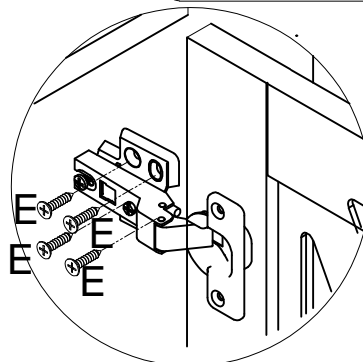
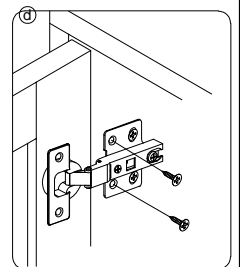
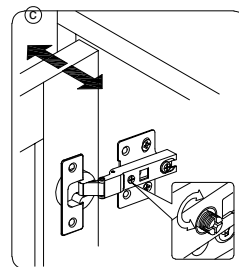
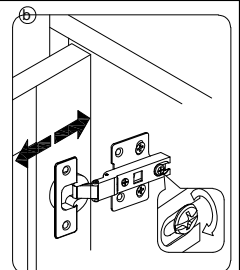
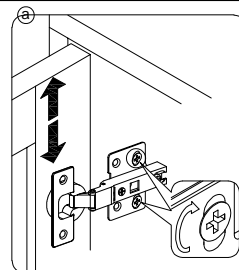
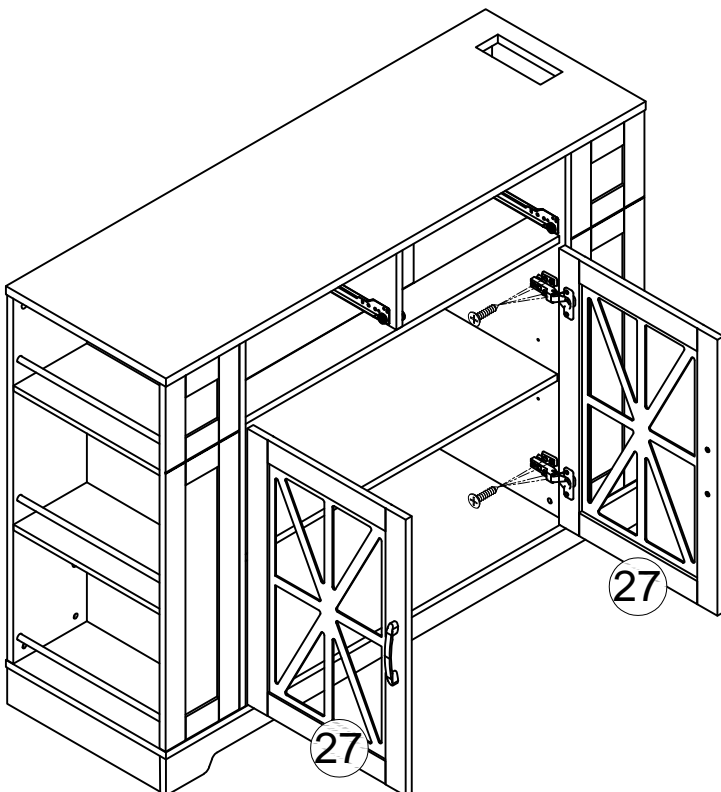

Screws
E x 16

Assembly Instruction Montageanleitung

ITEM:N890P388285+ N890P388287

Step 34

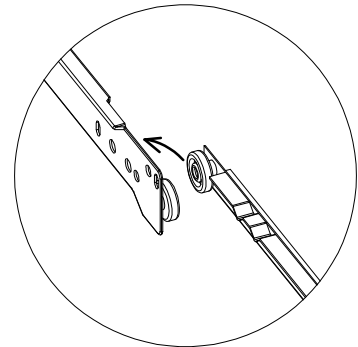
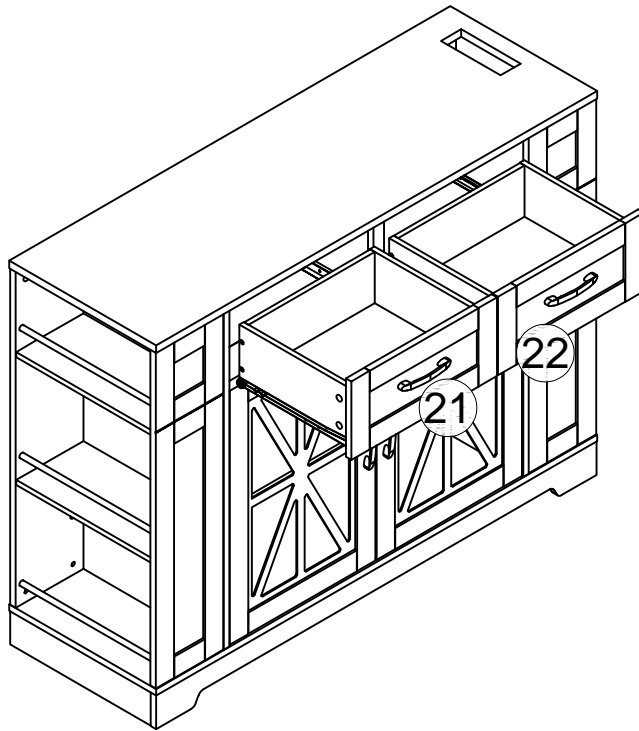

Step 35

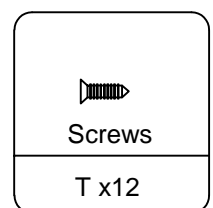
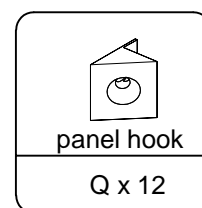
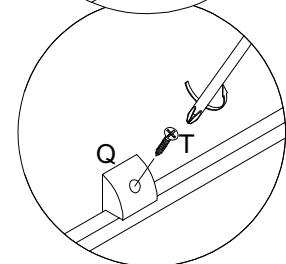
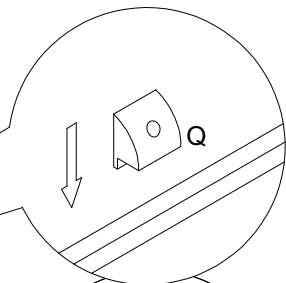
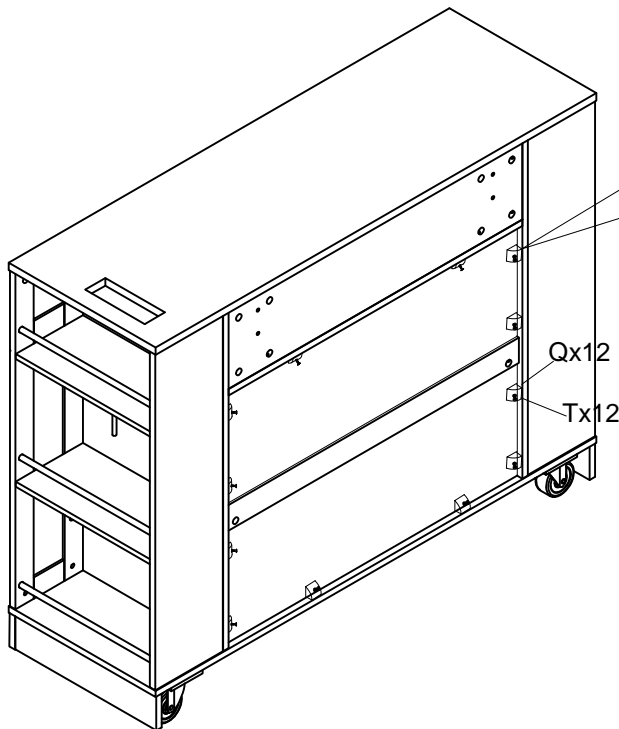

Assembly Instruction Montageanleitung

ITEM:N890P388285+ N890P388287

Step 36

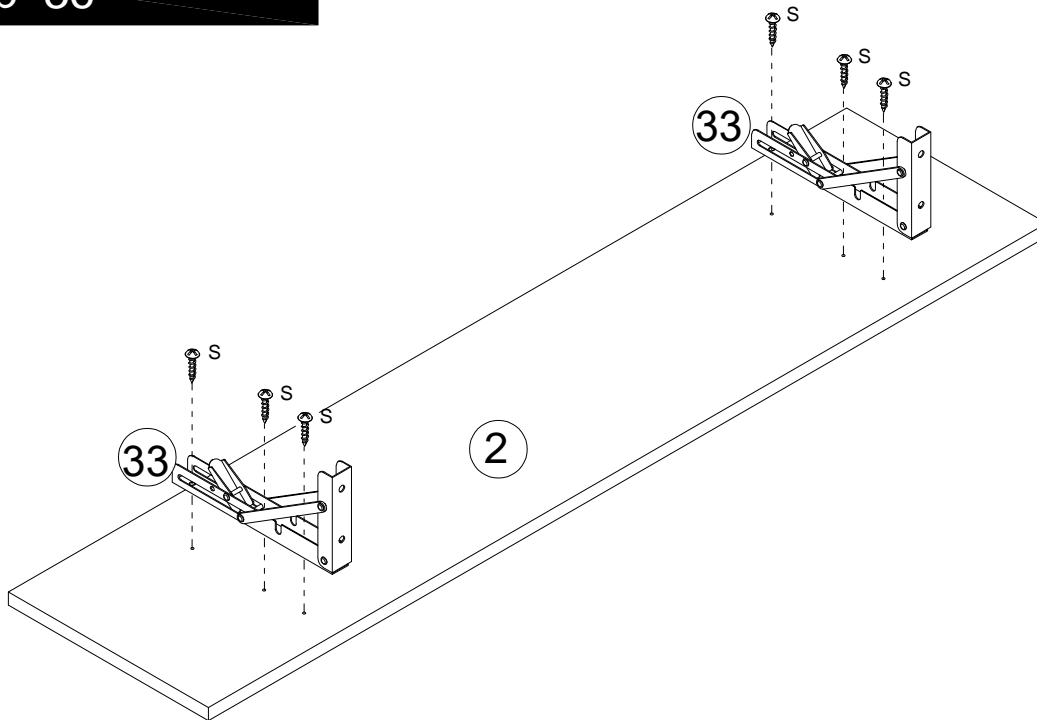

Screw
S x 6

Step 37

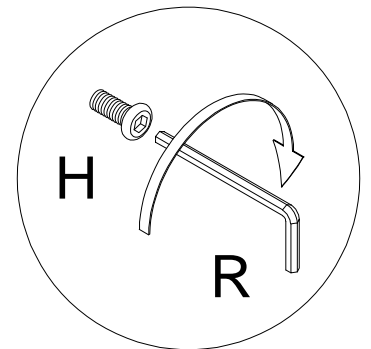
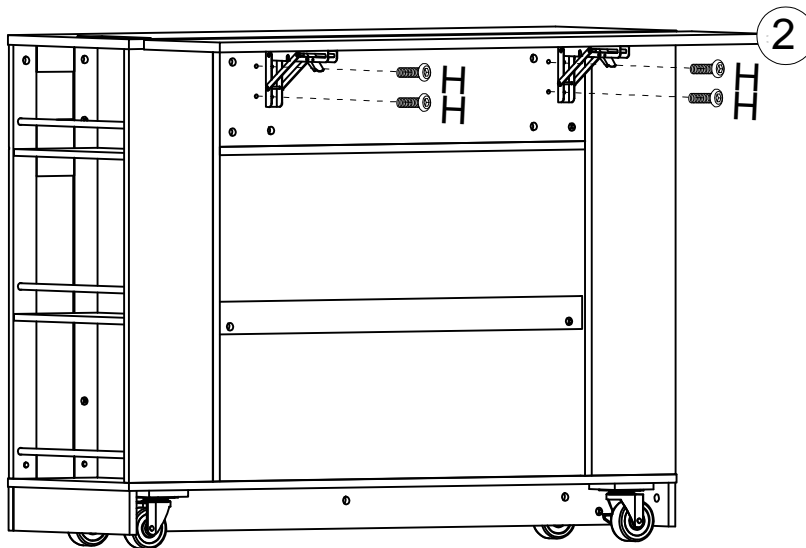

Bolts
H x 4

Assembly Instruction Montageanleitung

ITEM:N890P388285+ N890P388287

Step 38

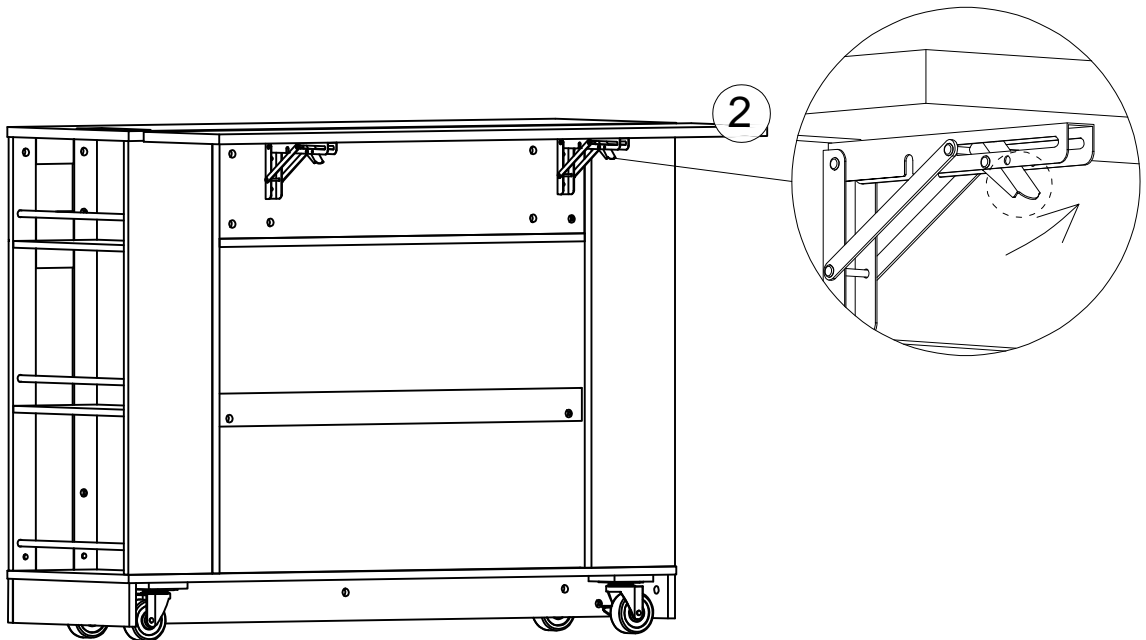

Step 39

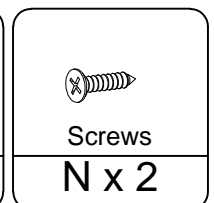
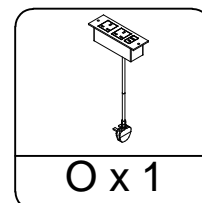
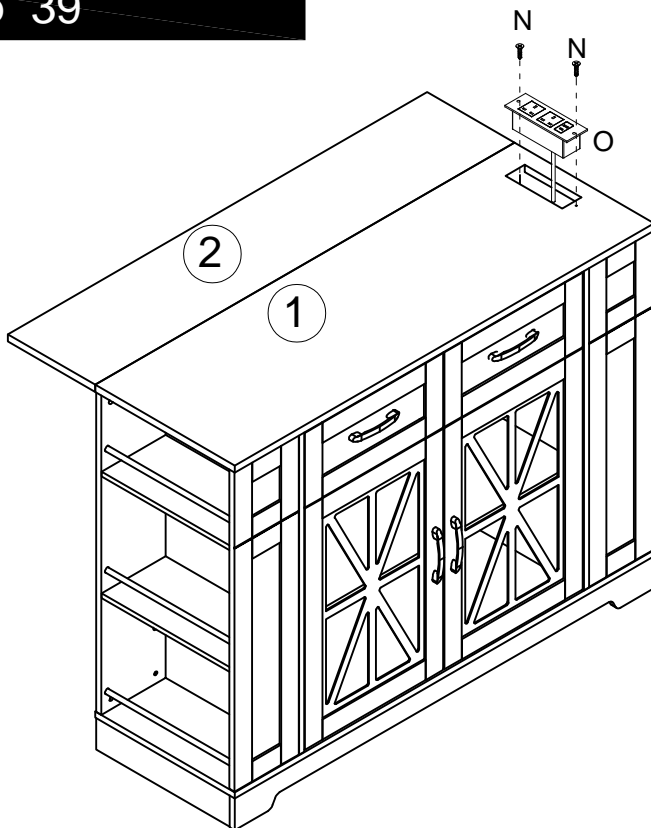

Assembly Instruction Montageanleitung

ITEM:N890P388285+ N890P388287

Step 40

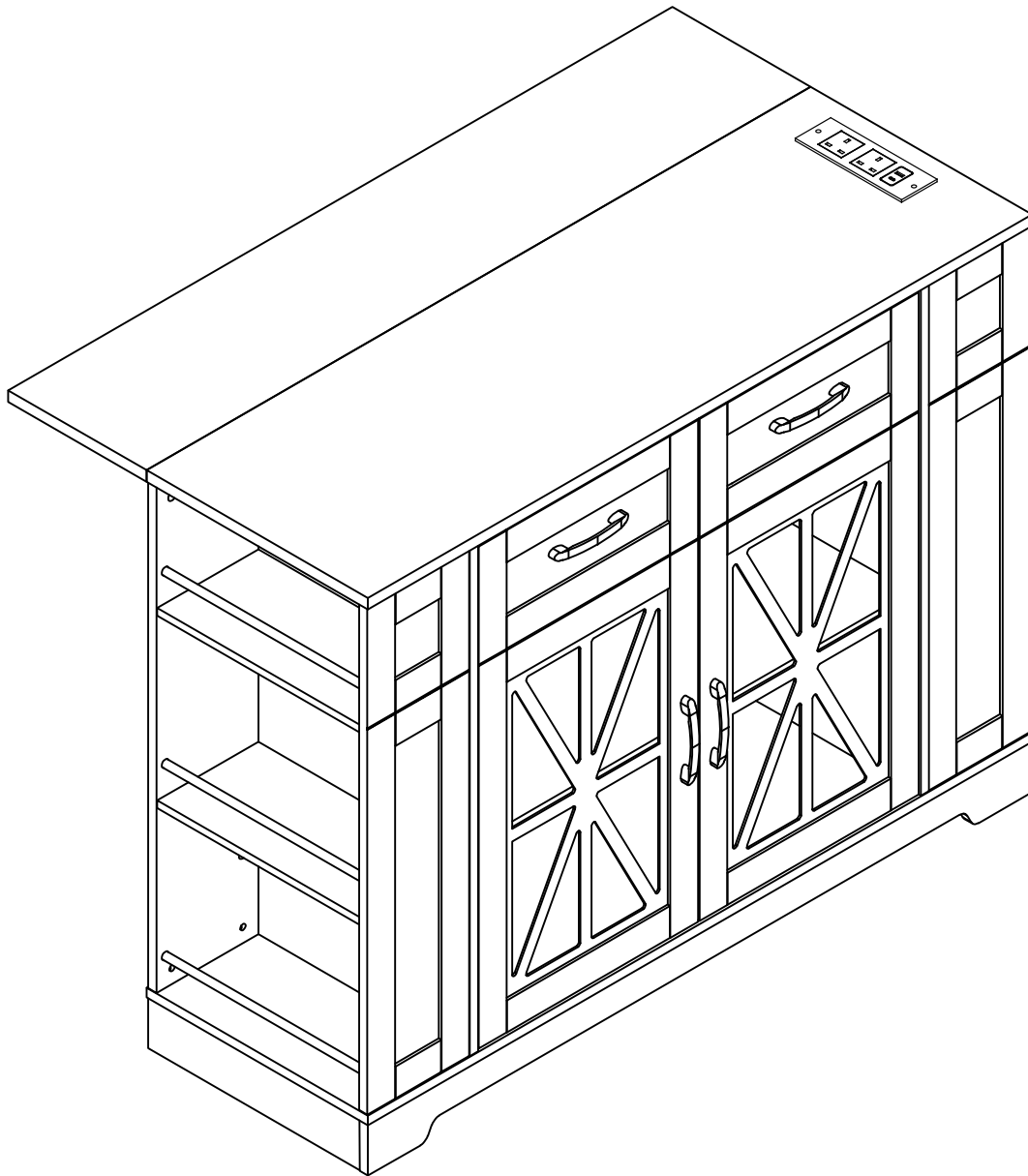

**UK
CA**



Con apposite
Accessories
in relation
to the product



UK DECLARATION OF CONFORMITY

1. Product model/product (product, type, batch or serial number):

Product Name: SOCKET

Model: NF02-BS01-13A/250V

2. Name and address of the manufacturer or his authorised representative:

DONGGUAN NANFAN ELECTRONIC TECHNOLOGY CO LTD

Room 202,NO.19 Wanbu Road,changpingTown,Dongguan Guangdong ,China

3. This declaration of conformity is issued under the sole responsibility of the manufacturer.

4. Object of the declaration (identification of electrical equipment allowing traceability, it may include a colour image of sufficient clarity where necessary for the identification of the electrical equipment).

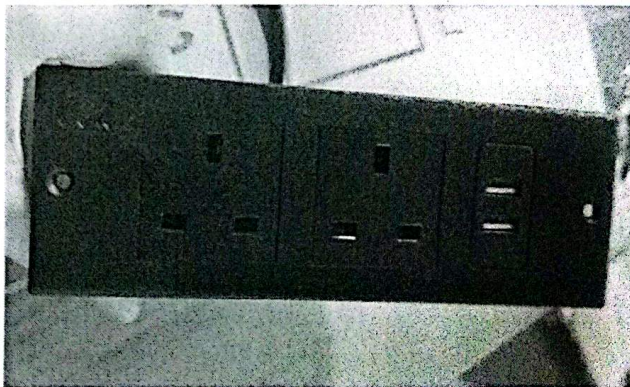



5. The object of the declaration described above is in conformity with the relevant Union harmonisation legislation:

LVD:UK SI 2016 No. 1101

EMC:SI 2016/1091

RoHS: Directive 2011/65/EU and its amendment (EU)2015/863

6. References to the relevant harmonised standards used or references to the other technical specifications in relation to which conformity is declared:

LVD :

BS EN IEC 62368-1:2020/A11:2020

EMC :

BS EN 55032:2015+A11:2020+A1:2020

BS EN IEC 61000-3-2:2019+A1:2021

BS EN 61000-3-3:2013+A1: 2019+A2:2021

BS EN 55032:2017+A11:2020



ROHS:

IEC 62321-4:2013+A1:2017

IEC 62321-5:2013

IEC 62321-6:2015

IEC 62321-7-1:2015

IEC 62321-7-2:2017

IEC 62321-8:2017

7.Additional information:

Signed for and on behalf of: DONGGUAN NANFAN ELECTRONIC TECHNOLOGY CO LTD

(place and date of issue : December 24.2025

Room 202,NO.19 Wanbu Road,changpingTown,Dongguan Guangdong ,China

(name, function) (signature): *Hu Lang (Business manager)*

