

Installationsanleitung/Installation Instruction/Instruction d'installation/
Istruzioni di installazione/Instrucciones de instalación/Installatie-instructies/
Installationsanvisningar/Instrukcje instalacji
KITCHEN ISLAND-N639P375983/N639P375984/N639P375985



DE: Unser Produkt wird Ihnen in 3 Paketen geliefert. Die Lieferzeiten dieser 3 Pakete können abweichen, bitte haben Sie etwas Geduld und vielen Dank für Ihr Verständnis.

UK: Our product will be delivered to you in 3 packages. The delivery times of these 3 packages may differ, please be patient and thank you for your understanding.

FR: Notre produit vous sera livré en 3 colis. Les délais de livraison de ces 3 colis peuvent différer, soyez patient et merci pour votre compréhension.

IT: Il nostro prodotto verrà consegnato in 3 pacchi. I tempi di consegna di questi 3 pacchi possono variare; vi preghiamo di avere un po' di pazienza e vi ringraziamo per la vostra comprensione.

ES: Nuestro producto se entregará en 3 paquetes. Los tiempos de entrega de estos 3 paquetes pueden variar; por favor, tenga un poco de paciencia y gracias por su comprensión.

NL: Ons product wordt in 3 pakketten bij u geleverd. De levertijden van deze 3 pakketten kunnen verschillen, we vragen om uw gedulden bedanken u voor uw begrip.

SE: Vår produkt kommer att levereras till dig i 3 paket. Leveranstiderna för dessa 3 paket kan variera, vi ber om ditt tålamod och tackar för din förståelse.

PL: Nasz produkt zostanie dostarczony w 3 paczkach. Czas dostawy tych 3 paczek może się różnić, prosimy o cierpliwość i dziękujemy za zrozumienie.

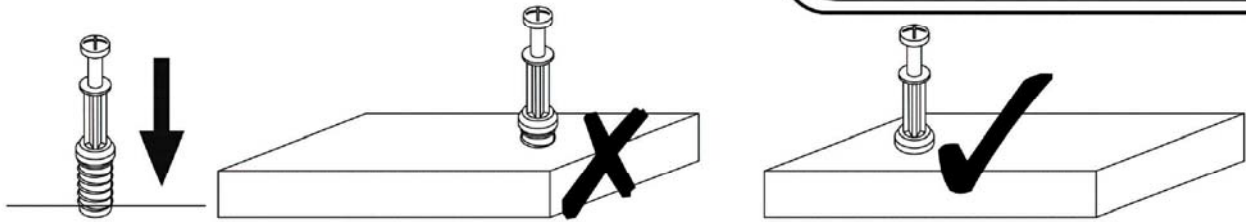

EN_QUICKFIT: Tighten quickfit until shoulder is flush with panel. Do not overtighten or undertighten.

FR_RACCORD RAPIDE: Faites serrer le raccord rapide jusqu'à ce que l'épaulement soit parfaitement encastré dans le panneau. Il ne faut ni trop serrer ni insuffisamment serrer.

ES_QUICKFIT: Apriete quickfit hasta que el hombro se descargue con el panel. NO lo sobreapriete ni lo apriete poco.

DE_QUICKFIT: Ziehen Sie den Quickfit fest, bis die Schulter mit der Platte bündig ist. Bitte nicht zu fest oder zu schwach anziehen.

IT_MONTAGGIO RAPIDO: Stringere il montaggio rapido fino a quando la spalla è a filo con il pannello, non stringere troppo o troppo poco.

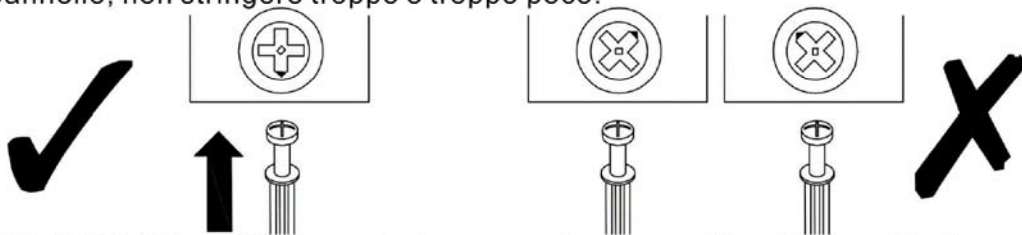

EN_CAM LOCK: When fitting cam lock, ensure starting position is correct before you insert connecting quickfit.

FR_SERRURE BATTEUSE: Avant d'insérer la serrure batteuse, veillez à la bonne orientation avant d'insérer le raccord rapide.

ES_CIERRE DE LA CÁMARA: Cuando instale el cierre de la cámara, asegúrese de que la posición de inicio es correcta antes de que inserte el quickfit conector.

DE_CAM-LOCK: Achten Sie bei der Montage des Cam-Locks auf die richtige Ausgangsposition, bevor Sie den Quickfit einsetzen.

IT_BLOCCAGGIO A CAMMA: Quando si monta il bloccaggio a camma, assicurarsi che la posizione iniziale sia corretta prima di inserire il montaggio rapido di collegamento.

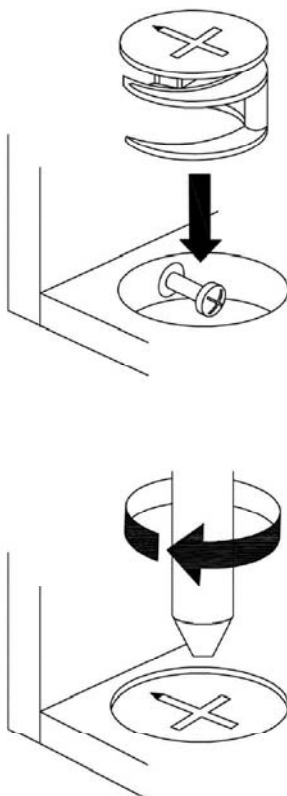

EN_Quickfit head should be in the centre of the cam lock when the two panels are joined.

Cam lock should be inserted before quickfit.

FR_Lorsque les deux panneaux sont assemblés, la tête du raccord rapide doit reposer au centre de la serrure batteuse. Il faut insérer la serrure batteuse avant le raccord rapide.

ES_El cabezal del quickfit debe estar en el centro del cierre de la cámara cuando se unan los dos paneles.

Se debe insertar el cierre de la cámara antes que el quickfit.

DE_Der Quickfit-Kopf sollte sich in der Mitte des Cam-Locks befinden, wenn die beiden Platten zusammengefügt sind.

Der Cam-Lock sollte vor dem Quickfit eingesetzt werden.

IT_La testa del montaggio rapido deve trovarsi al centro del bloccaggio a camma quando i due pannelli sono uniti.

Il Bloccaggio a Camma deve essere inserito prima del montaggio rapido.

EN_Turn cam lock clockwise to tighten.

FR_Faites tourner la serrure batteuse dans le sens des aiguilles d'une montre pour la resserrer.

ES_Gire el cierre de la cámara en sentido horario para apretarlo.

DE_Drehen Sie den Cam-Lock im Uhrzeigersinn, um ihn festzuziehen.

IT_Ruotare il bloccaggio a camma in senso orario per stringere.

(DE):

1. Die maximale Tragfähigkeit des Produkts beträgt 60 kg, bitte nicht überladen.
2. Lassen Sie Kinder nicht auf Möbel klettern, da dies Umkippen und schwere Verletzungen verursachen kann.
3. Um die Sicherheit zu gewährleisten, installieren Sie bitte gemäß der Anleitung und ziehen Sie bei Bedarf Fachleute zurate.
4. Stellen Sie Möbel nicht in die Nähe von Feuerquellen oder heißen Gegenständen, um das Brandrisiko zu vermeiden.
5. Stellen Sie Möbel nicht in feuchten Umgebungen auf, um Materialschäden zu verhindern.
6. Überprüfen Sie regelmäßig alle Verbindungen und Befestigungen, um sicherzustellen, dass sie fest sind, um Unfälle zu vermeiden.
7. Reinigen Sie Möbel mit einem feuchten Tuch oder Alkohol, vermeiden Sie die Verwendung von reinigenden Mitteln mit ätzenden Chemikalien.

(UK):

1. The maximum weight capacity of the product is 60kg; do not overload.
2. Do not allow children to climb on furniture, as it may cause tipping and serious injury.
3. For safety, please install correctly according to the instructions, and seek professional assistance if necessary.
4. Do not place furniture near fire sources or hot items to avoid fire risk.
5. Do not place furniture in damp environments to prevent material damage.
6. Regularly check all connections and fasteners to ensure they are secure to prevent accidents.
7. Clean furniture with a damp cloth or alcohol; avoid using cleaners with corrosive chemicals.

(FR):

1. La capacité maximale de charge du produit est de 60 kg, ne pas surcharger.
2. Ne laissez pas les enfants grimper sur les meubles, cela peut entraîner un basculement et des blessures graves.
3. Pour garantir la sécurité, veuillez installer correctement selon les instructions et demander de l'aide à des professionnels si nécessaire.
4. Ne placez pas les meubles près de sources de chaleur ou d'objets chauds pour éviter les risques d'incendie.
5. Ne placez pas les meubles dans des environnements humides pour éviter d'endommager les matériaux.
6. Vérifiez régulièrement tous les raccords et fixations pour vous assurer qu'ils sont sécurisés afin d'éviter les accidents.
7. Nettoyez les meubles avec un chiffon humide ou de l'alcool, évitez d'utiliser des nettoyeurs contenant des produits chimiques corrosifs.

(IT):

1. La capacità massima del prodotto è di 60 kg, non sovraccaricare.
2. Non permettere ai bambini di arrampicarsi sui mobili, poiché ciò potrebbe causare ribaltamenti e gravi infortuni.
3. Per garantire la sicurezza, installare correttamente secondo le istruzioni e chiedere assistenza a professionisti se necessario.
4. Non posizionare i mobili vicino a fonti di calore o oggetti caldi per evitare rischi di incendio.
5. Non posizionare i mobili in ambienti umidi per prevenire danni ai materiali.
6. Controllare regolarmente tutte le connessioni e le viti per assicurarsi che siano sicure e prevenire incidenti.
7. Pulire i mobili con un panno umido o alcol; evitare di utilizzare detergenti contenenti sostanze chimiche corrosive.

(ES):

1. La capacidad máxima del producto es de 60 kg, no sobrecargar.
2. No permita que los niños escalen los muebles, ya que puede provocar vuelcos y lesiones graves.
3. Para garantizar la seguridad, instale correctamente según las instrucciones y busque asistencia profesional si es necesario.
4. No coloque muebles cerca de fuentes de fuego u objetos calientes para evitar riesgos de incendio.
5. No coloque muebles en ambientes húmedos para evitar daños en los materiales.
6. Revise regularmente todas las conexiones y sujetadores para asegurarse de que estén firmes y prevenir accidentes.
7. Limpie los muebles con un paño húmedo o alcohol; evite usar limpiadores con productos químicos corrosivos.

(NL):

1. De maximale draagcapaciteit van het product is 60 kg; niet overbelasten.
2. Laat kinderen niet op meubels klimmen, dit kan omvallen en ernstige verwondingen veroorzaken.
3. Installeer correct volgens de instructies voor de veiligheid en vraag indien nodig om professionele hulp.
4. Plaats meubels niet in de buurt van vuurbronnen of hete voorwerpen om brandrisico te voorkomen.
5. Plaats meubels niet in vochtige omgevingen om materiaalschade te voorkomen.
6. Controleer regelmatig alle verbindingen en bevestigingen om ervoor te zorgen dat ze stevig zijn en ongelukken te voorkomen.
7. Maak meubels schoon met een vochtige doek of alcohol; vermijd het gebruik van schoonmaakmiddelen met bijtende chemicaliën.

(SE):

1. Den maximala belastningen för produkten är 60 kg; överbelasta inte.
2. Låt inte barn klättra på möbler, eftersom det kan leda till att de tippar och orsakar allvarliga skador.
3. För att säkerställa säkerheten, installera korrekt enligt instruktionerna och be om professionell hjälp vid behov.
4. Placera inte möbler nära värmekällor eller heta föremål för att undvika brandrisk.
5. Placera inte möbler i fuktiga miljöer för att förhindra materialskador.
6. Kontrollera regelbundet alla anslutningar och fästen för att säkerställa att de är säkra för att förhindra olyckor.
7. Rengör möbler med en fuktig trasa eller alkohol; undvik att använda rengöringsmedel med frätande kemikalier.

(PL):

1. Maksymalne obciążenie produktu wynosi 60 kg; nie przeciążaj.
2. Nie pozwalaj dzieciom wspinać się na meble, ponieważ może to prowadzić do przewrócenia i poważnych obrażeń.
3. Aby zapewnić bezpieczeństwo, zainstaluj poprawnie zgodnie z instrukcjami i w razie potrzeby skorzystaj z pomocy specjalistów.
4. Nie stawiaj mebli w pobliżu źródeł ognia lub gorących przedmiotów, aby uniknąć ryzyka pożaru.
5. Nie umieszczaj mebli w wilgotnym środowisku, aby zapobiec uszkodzeniu materiałów.
6. Regularnie sprawdzaj wszystkie połączenia i mocowania, aby upewnić się, że są solidne, aby zapobiec wypadkom.
7. Czyść meble wilgotną szmatką lub alkoholem; unikaj używania środków czyszczących z żrącymi chemikaliami.

Ausstattung der Komponenten

Bitte überprüfen Sie, ob Sie alle unten aufgeführten Teile haben.
Hinweis: Die unten angegebenen Mengen sind die korrekte Menge, um die Montage zu vervollständigen. In einigen Fällen können mehr Beschläge geliefert werden, als benötigt werden.

Components fittings

Please check you have all the panels listed below. Note, The quantities below are the correct amount to complete the assembly. In some cases more fittings may be supplied than are required

Accessoires des composants

Veillez vérifier que vous disposez de tous les panneaux énumérés ci-dessous. Remarque : les quantités indiquées ci-dessous correspondent à la quantité nécessaire pour compléter l'assemblage. Dans certains cas, il se peut que le nombre de raccords fournis soit supérieur au nombre de raccords nécessaires.

Componenti di fissaggio

Verificare di disporre di tutti i pannelli elencati di seguito. Nota: le quantità indicate di seguito sono quelle corrette per completare l'assemblaggio. In alcuni casi possono essere forniti più raccordi di quelli necessari.

Componentes

Compruebe que dispone de todos los paneles que se indican a continuación. Nota: las cantidades indicadas a continuación son las necesarias para completar el montaje. En algunos casos, es posible que se suministren más accesorios de los necesarios.

Onderdelen

Controleer of je alle hieronder vermelde panelen hebt.
Let op: de onderstaande hoeveelheden zijn de juiste hoeveelheid om de assemblage te voltooien. In sommige gevallen kan er meer beslag worden geleverd dan nodig is.

Komponenter beslag

Kontrollera att du har alla paneler som anges nedan. Notera, kvantiteterna nedan är den korrekta mängden för att slutföra monteringen. I vissa fall kan fler beslag levereras än vad som krävs.

Elementy wyposażenia

Sprawdź, czy masz wszystkie panele wymienione poniżej.
Uwaga: Poniższe ilości są prawidłowe do ukończenia montażu. W niektórych przypadkach może być dostarczonych więcej elementów niż jest to wymagane.

N639P375983-BOX:1/3

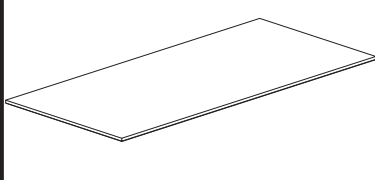
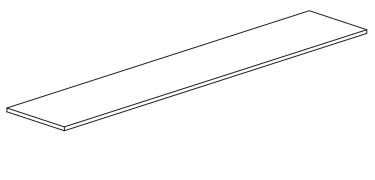
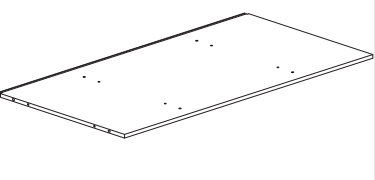
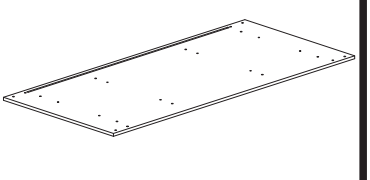
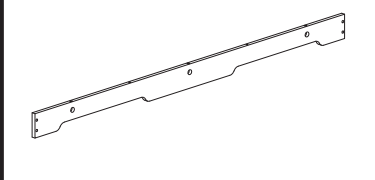
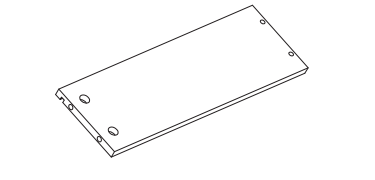
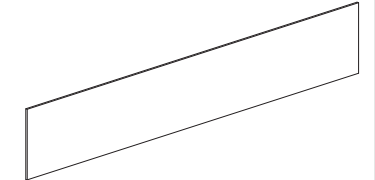
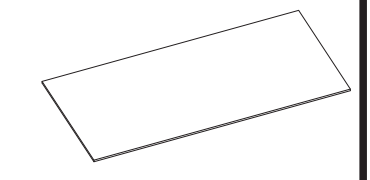



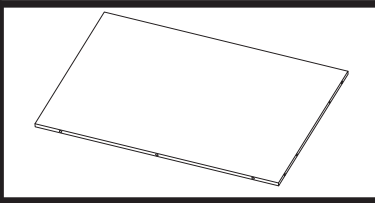
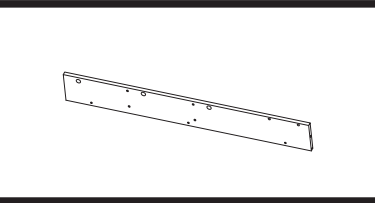
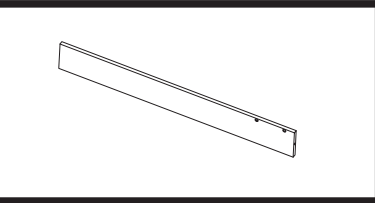
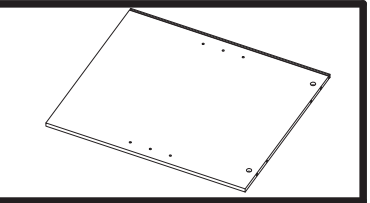
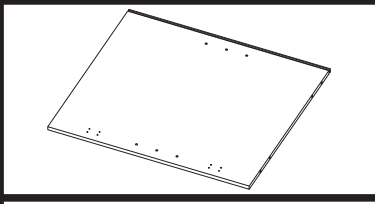
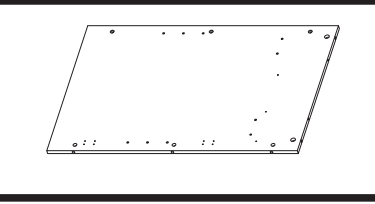
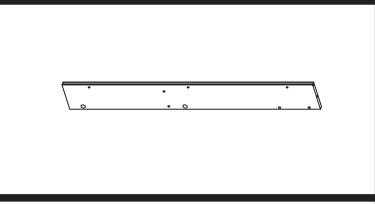
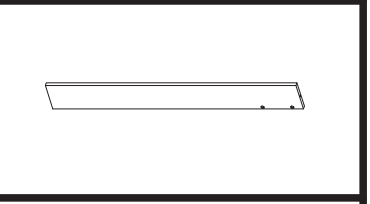
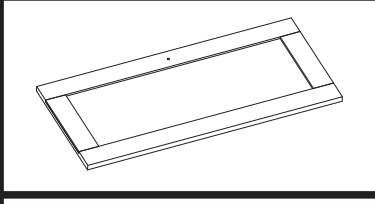
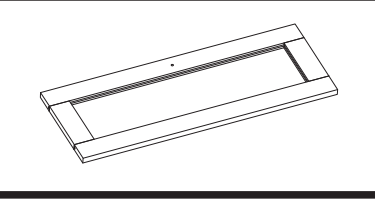
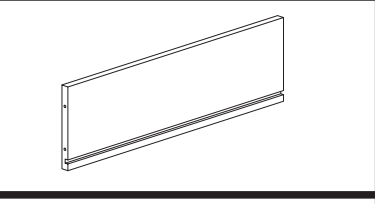
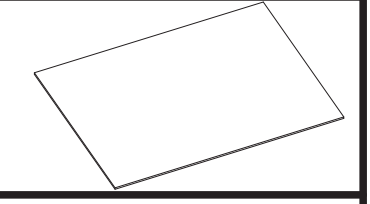

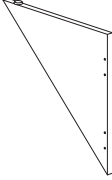
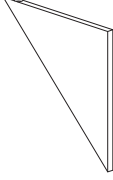
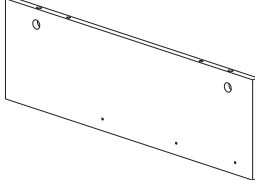
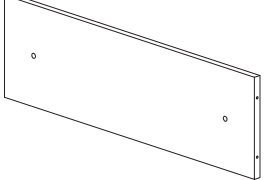
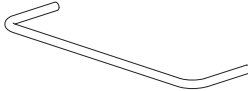
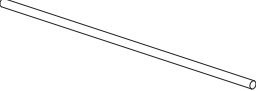
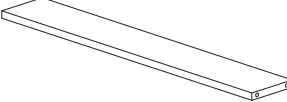
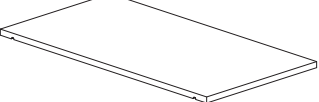
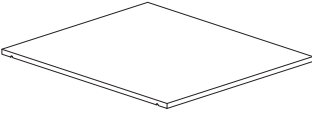
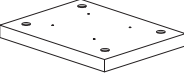
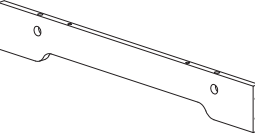
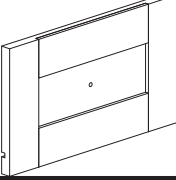
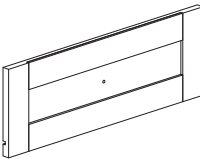
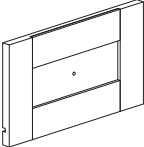
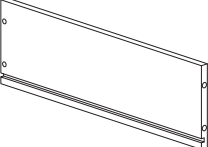
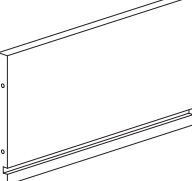
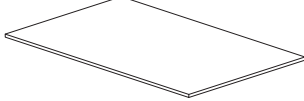
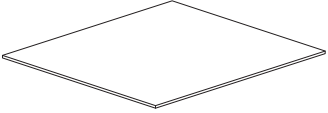



| | | | |
|--|---|--|---|
|  |  |  |  |
| ③ x1pc | ④ x1pc | ⑥ x1pc | ②② x1pc |
|  |  |  |  |
| ②③ x2pcs | ③① x3pcs | ③⑥ x1pc | ③⑦ x2pcs |

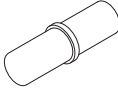

N639P375984-BOX:2/3

| | | | |
|--|---|--|---|
|  |  |  |  |
| ⑦ x1pc | ⑧ x1pc | ⑨ x1pc | ①⑥ x1pc |
|  |  |  |  |
| ①⑦ x1pc | ①⑧ x1pc | ①⑨ x1pc | ②① x1pc |
|  |  |  |  |
| ②⑤ x2pcs | ②⑥ x2pcs | ③④ x1pc | ③⑧ x1pc |

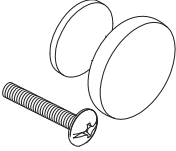
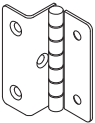
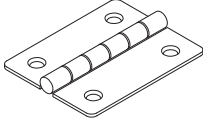
| | | | |
|---|---|--|---|
|  |  |  |  |
| ① x 1pc | ② x 1pc | ⑤ x 2pcs | ⑩ x 2pcs |
|  |  |  |  |
| ⑪ x 2pcs | ⑫ x 5pcs | ⑬ x 3pcs | ⑭ x 2pcs |
|  |  |  |  |
| ⑮ x 1pc | ⑳ x 5pcs | ㉔ x 2pcs | ㉗ x 1pc |
|  |  |  |  |
| ㉘ x 1pcs | ㉙ x 1pcs | ㉛ x 3pcs | ㉜ x 2pcs |
|  |  | | |
| ㉛ x 2pcs | ㉝ x 1pc | | |

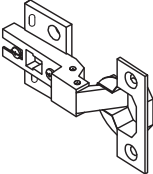
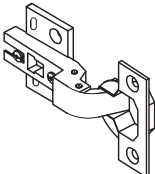
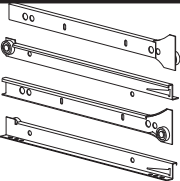
Hardware Kit:N639P375985-BOX:3/3

| | | | | |
|--|--|---|--|--|
|  ø15x10mm |  ø6x34mm |  M5x38mm |  ø3.5x12mm |  ø6x30mm |
| A x56pcs | B x56pcs | C x48pcs | D x112pcs | E x46pcs |
|  ø1/4x23mm |  ø4*15mm |  |  M4 |  |
| F x24pcs | G x20pcs | H x12pcs | I x1pc | J x7pcs |
|  |  | ×3  ×2  |  |  |
| K x4pcs | L x3pcs | M x5pcs | N x4pcs | O x4pcs |
|  GL DL CR DR | | | | |
| P x3pcs | | | | |

| | |
|--|--|
|  ø3.5x12mm |  ø4x15mm |
| D x112pcs | G x20pcs |

DE: Bitte beachten Sie, dass die Formen der Schrauben D und G ähnlich sind.

Bitte installieren Sie entsprechend der Anleitung und unterscheiden Sie sie!

UK: Please note that the shapes of screws D and G are similar. Please install according to the instructions and distinguish them!

FR: Notez que les vis D et G ont des formes similaires. Veuillez les installer en suivant les instructions pour les séparer!

IT: Si prega di notare che le forme delle viti D e G sono simili. Si prega di installarle seguendo le istruzioni e di distinguerle!

ES: Por favor, tenga en cuenta que las formas de los tornillos G y D son similares. Por favor, instálelos de acuerdo con las instrucciones y distíngalos.

NL: Let op, de vormen van schroeven G en D zijn vergelijkbaar. Installeer volgens de instructies en maak onderscheid tussen ze!

SE: Observera att formerna på skruvarna G och D är lika. Installera enligt anvisningarna och särskilj dem!

PL: Zauważ, że kształty śrub G i D są podobne.

Zainstaluj zgodnie z instrukcjami i rozróżnij je!

Installationsanleitung/Installation Instruction/Instruction d'installation/
 Istruzioni di installazione/Instrucciones de instalación/Installatie-instructies/
 Installationsanvisningar/Instrukcje instalacji

Schritt 1/Step 1/ étape 1/ passo1/paso 1 / stap 1/steg 1/ krok 1

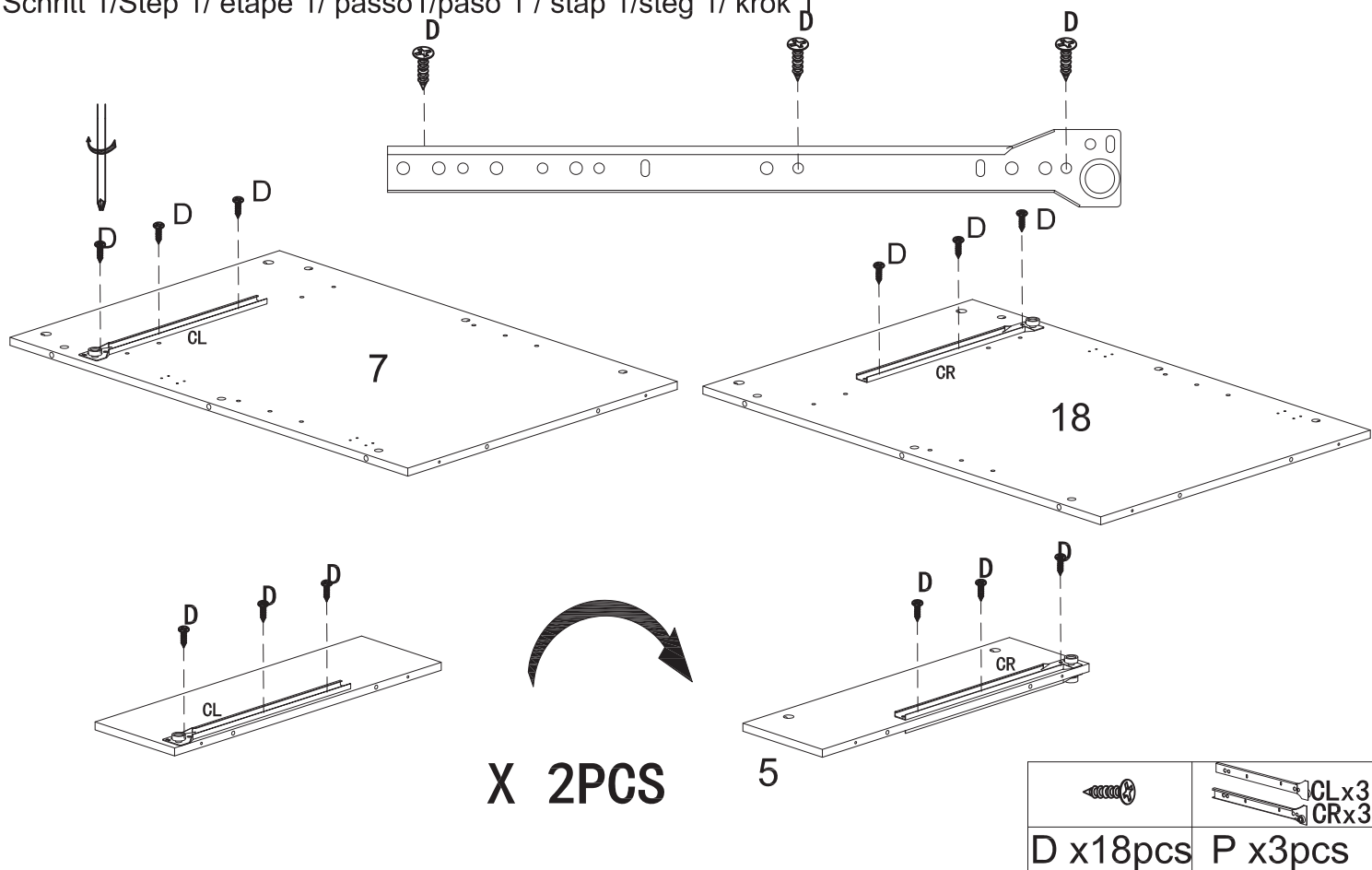



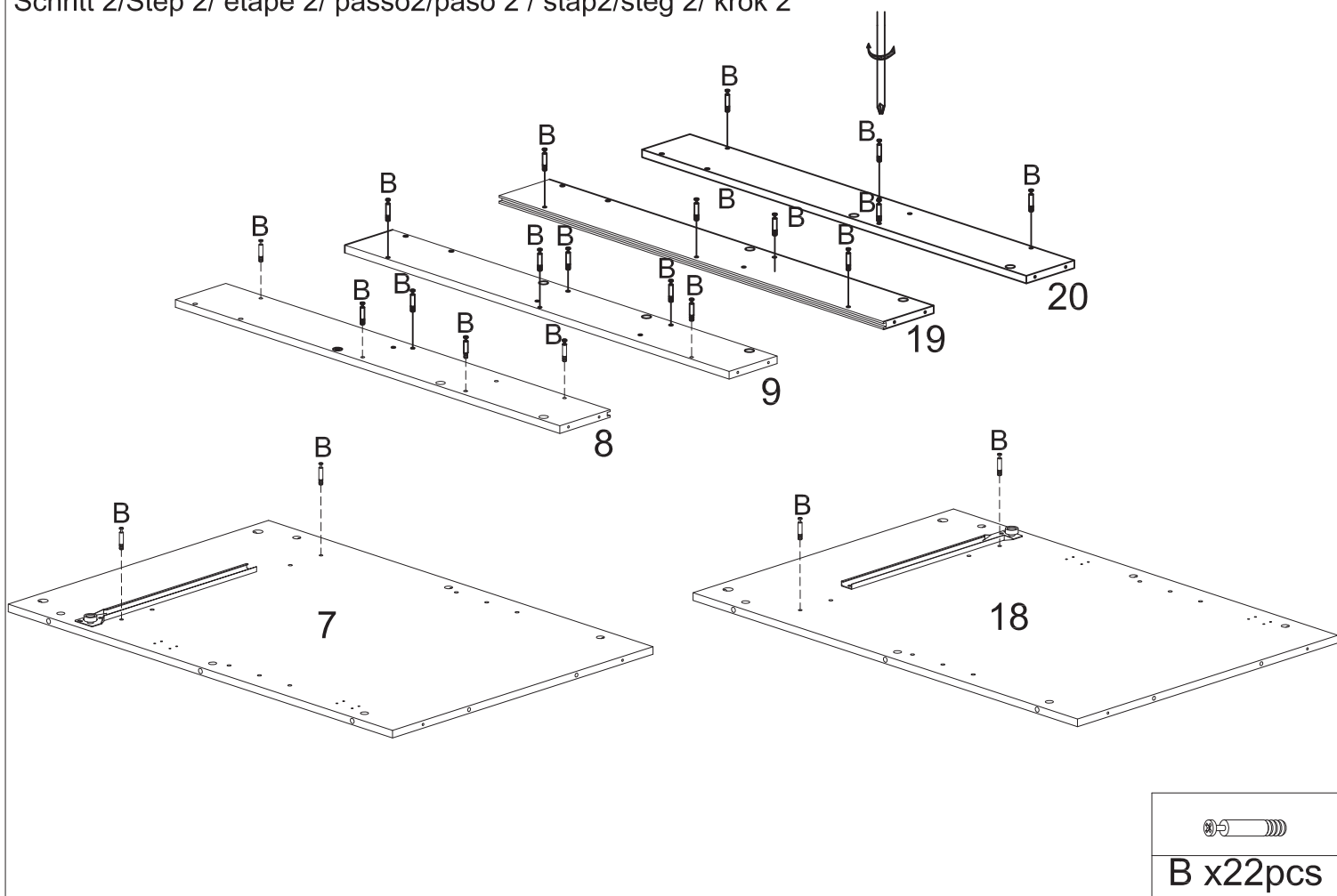

Schritt 2/Step 2/ étape 2/ passo2/paso 2 / stap2/steg 2/ krok 2

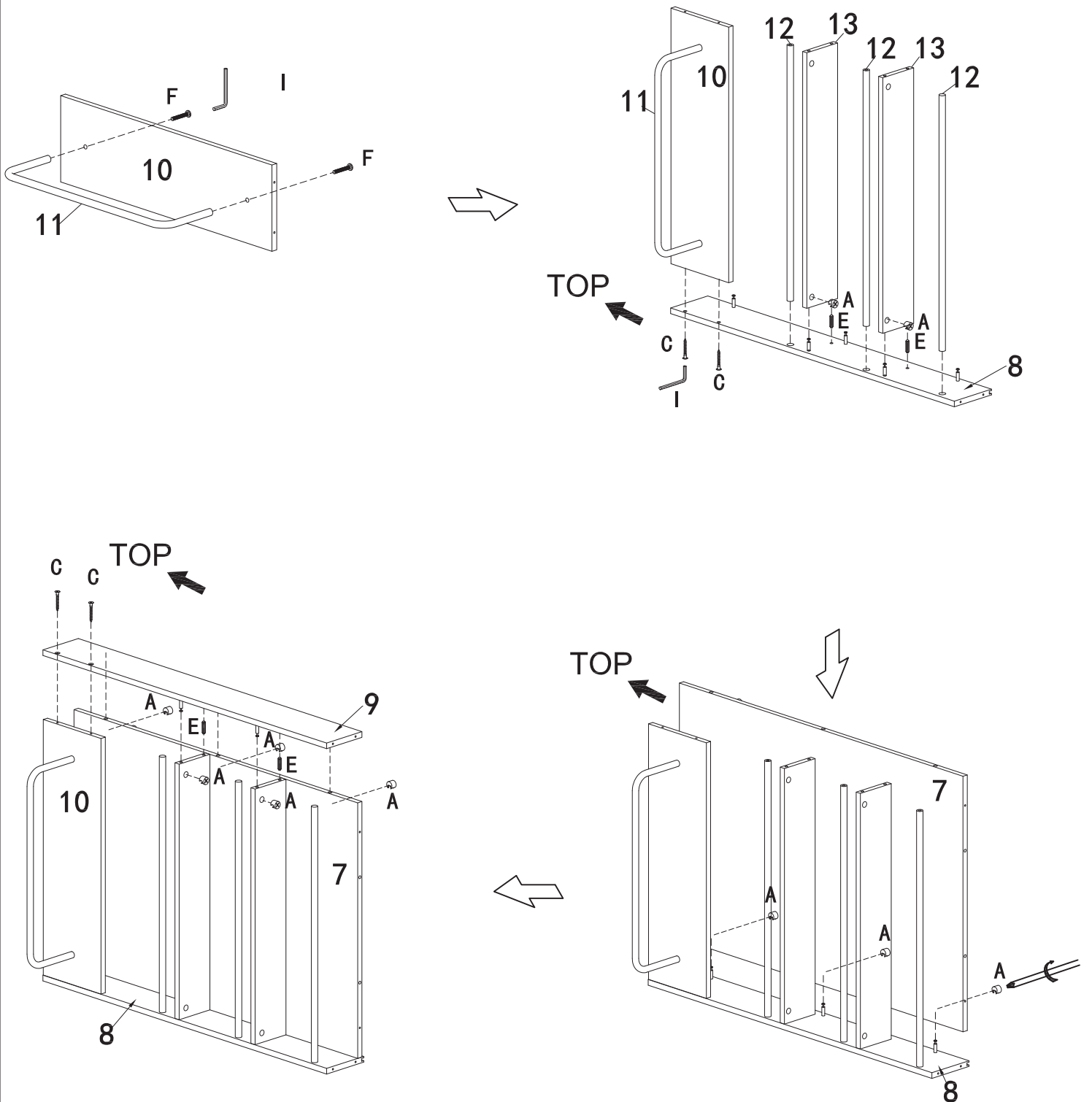

Installationsanleitung/Installation Instruction/Instruction d'installation/
 Istruzioni di installazione/Instrucciones de instalación/Installatie-instructies/
 Installationsanvisningar/Instrukcje instalacji

Schritt 3/Step 3/ étape 3/ passo 3/paso 3 / stap 3/steg 3/ krok 3



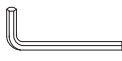

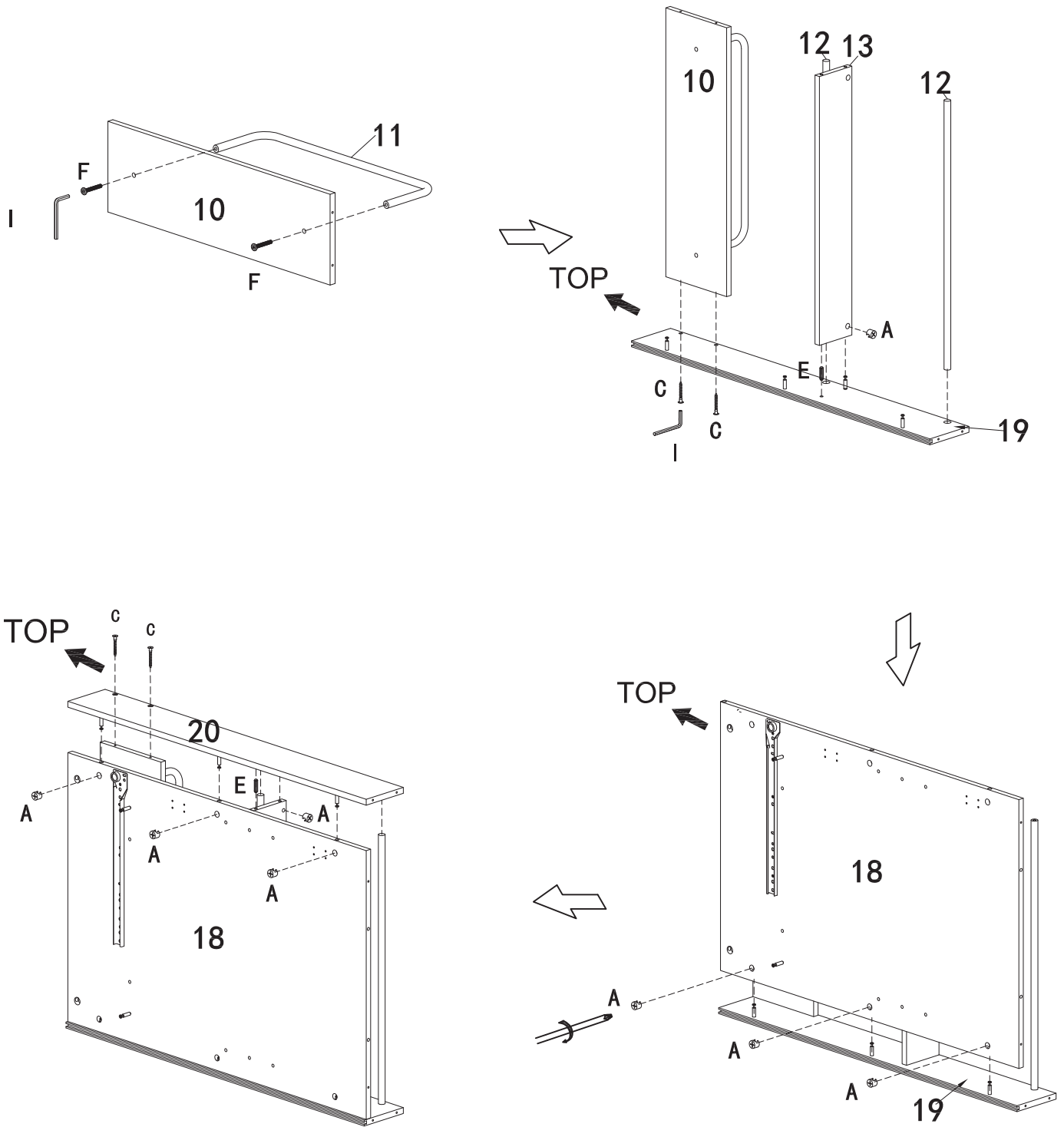

| | | | | |
|---|---|---|---|---|
|  |  |  |  |  |
| A x10pcs | C x4pcs | E x4pcs | F x2pcs | I |

Installationsanleitung/Installation Instruction/Instruction d'installation/
 Istruzioni di installazione/Instrucciones de instalación/Installatie-instructies/
 Installationsanvisningar/Instrukcje instalacji

Schritt 4/Step 4/ étape4/ passo 4/paso 4 / stap 4/steg 4/ krok 4



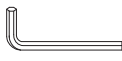

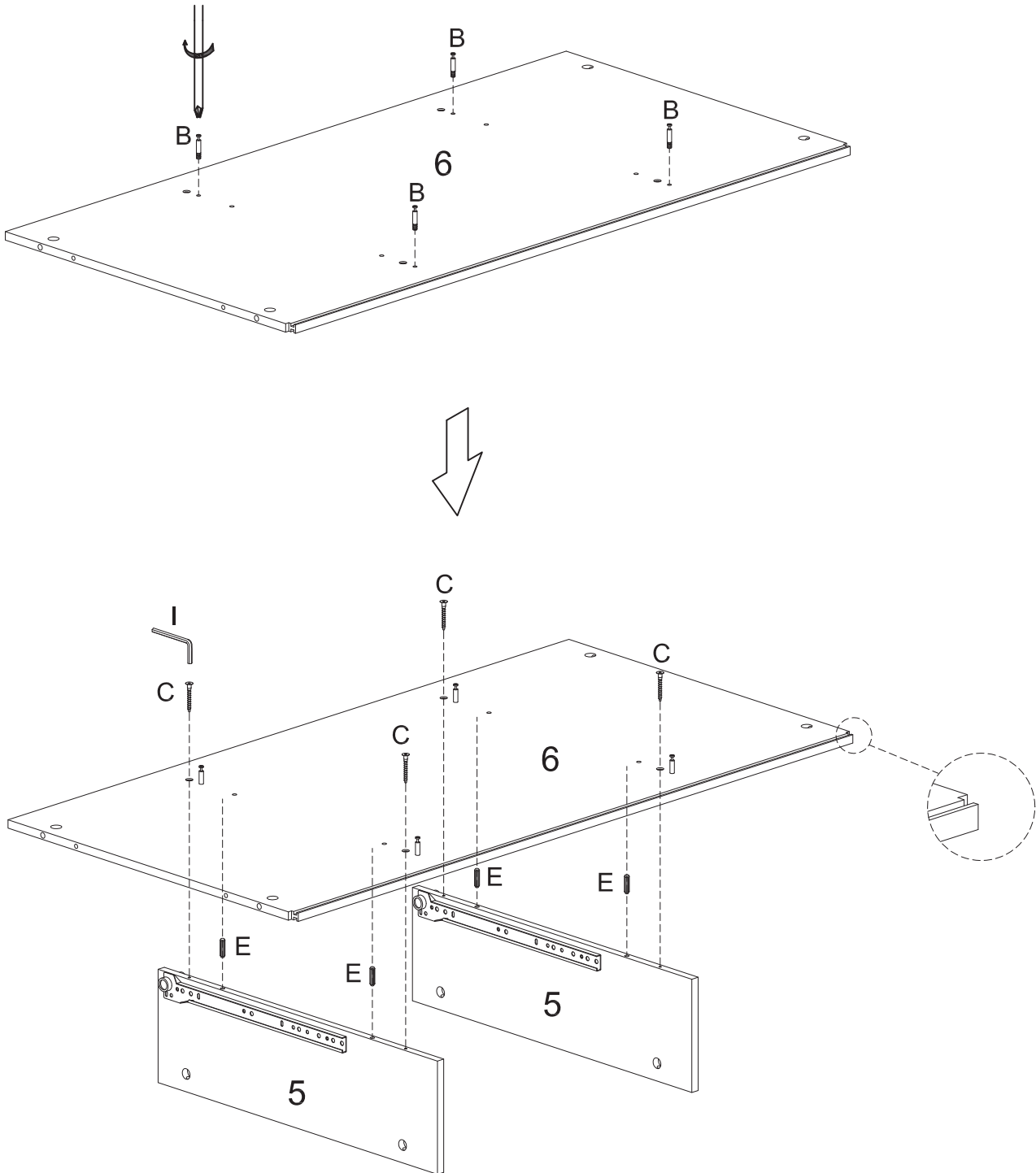

| | | | | |
|---|---|---|---|---|
|  |  |  |  |  |
| A x8pcs | C x4pcs | E x2pcs | F x2pcs | I |

Installationsanleitung/Installation Instruction/Instruction d'installation/
 Istruzioni di installazione/Instrucciones de instalación/Installatie-instructies/
 Installationsanvisningar/Instrukcje instalacji

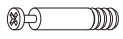
Schritt 5/Step 5/ étape 5/ passo 5/paso 5/ stap 5/steg 5/ krok 5





| | | | |
|---|---|---|---|
|  |  |  |  |
| B x4pcs | C x4pcs | E x4pcs | I |

Installationsanleitung/Installation Instruction/Instruction d'installation/
Istruzioni di installazione/Instrucciones de instalación/Installatie-instructies/
Installationsanvisningar/Instrukcje instalacji

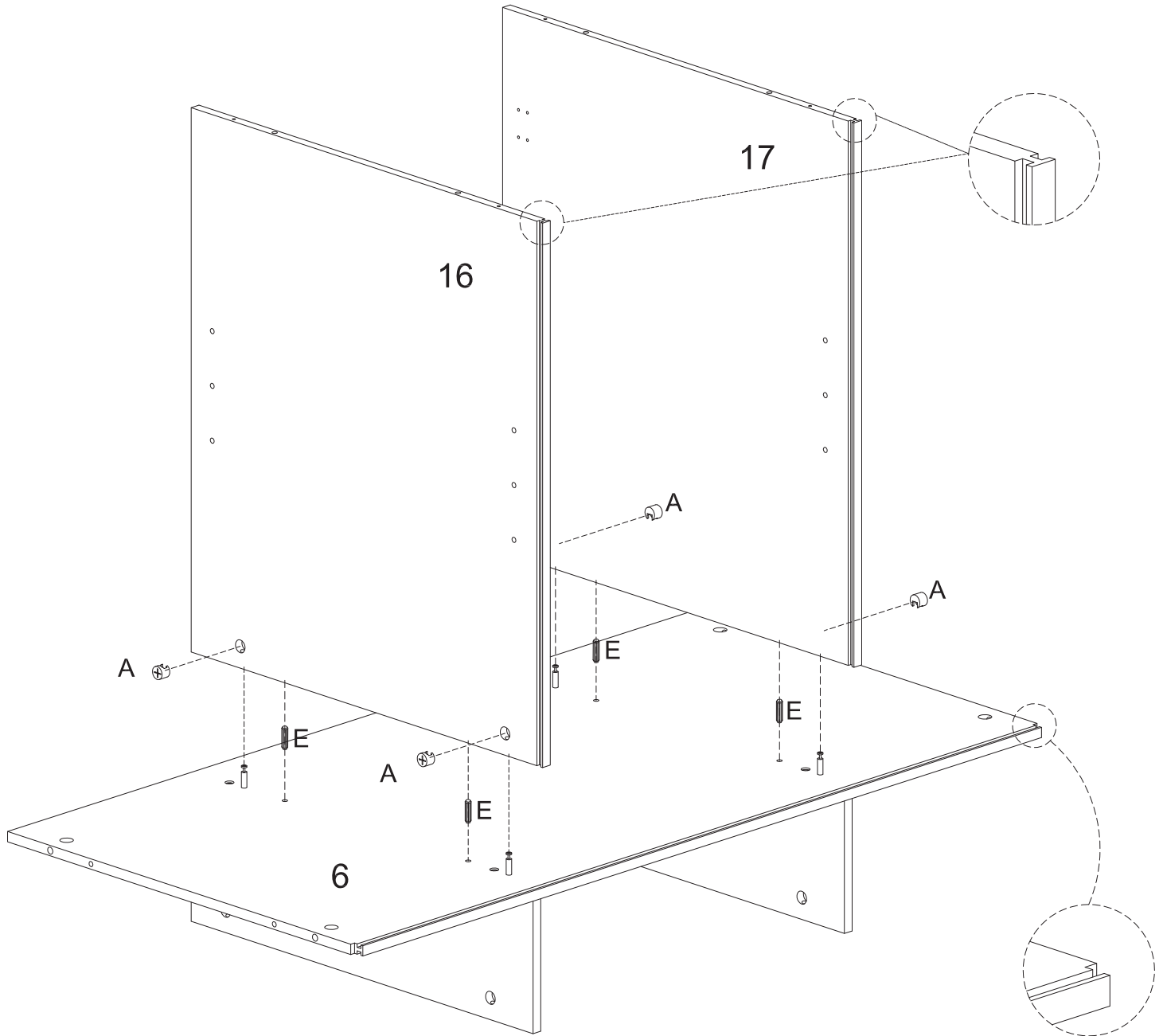
Schritt 6/Step 6/ étape 6/ passo 6/paso 6/ stap 6/steg 6/ krok 6





| | |
|---|---|
|  |  |
| A x4pcs | E x4pcs |

Installationsanleitung/Installation Instruction/Instruction d'installation/
 Istruzioni di installazione/Instrucciones de instalación/Installatie-instructies/
 Installationsanvisningar/Instrukcje instalacji

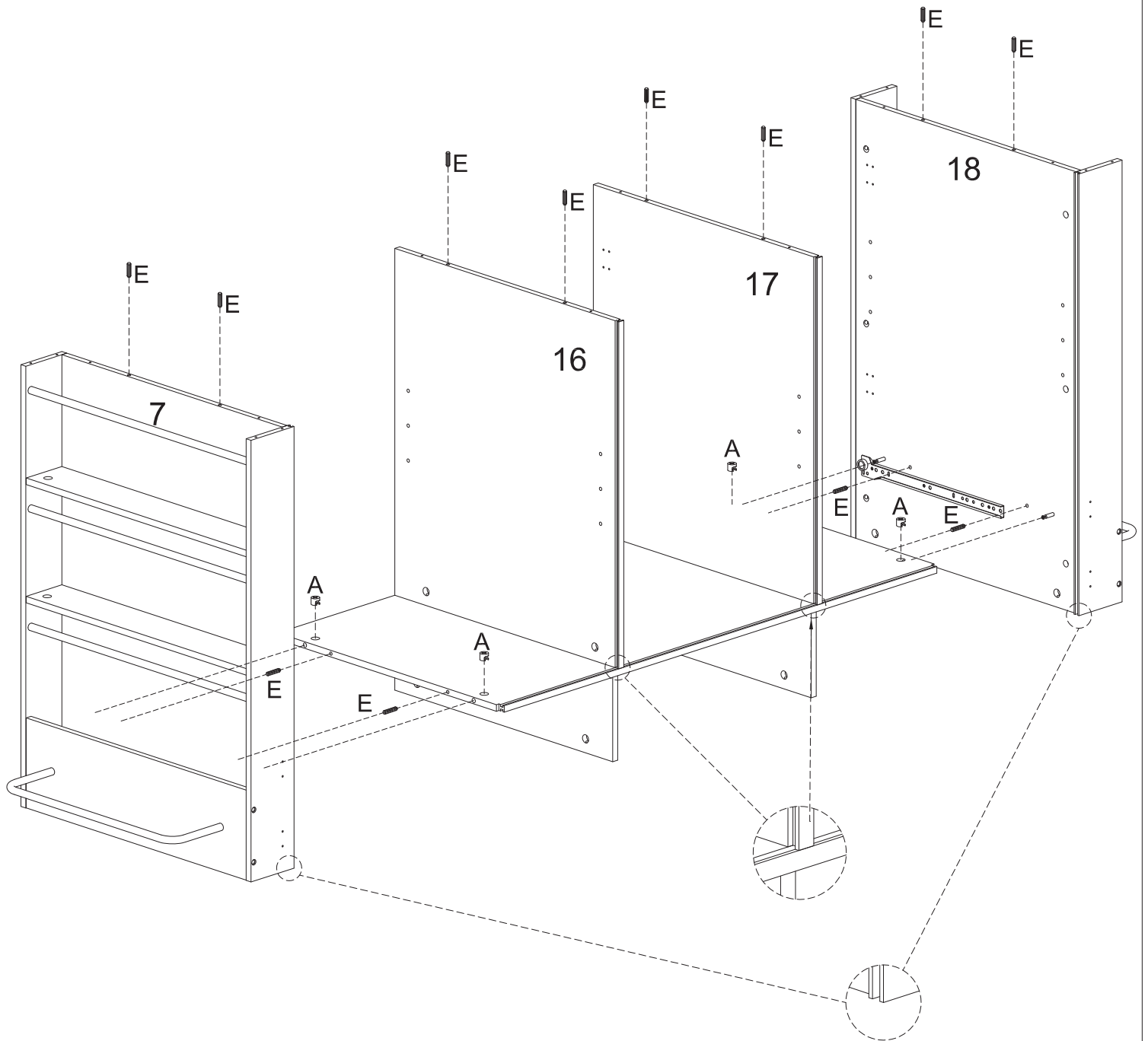
Schritt 7/Step 7/ étape 7/ passo 7/paso 7/ stap 7/steg 7/ krok 7



| | |
|---|---|
|  |  |
| A x4pcs | E x12pcs |

Installationsanleitung/Installation Instruction/Instruction d'installation/
Istruzioni di installazione/Instrucciones de instalación/Installatie-instructies/
Installationsanvisningar/Instrukcje instalacji

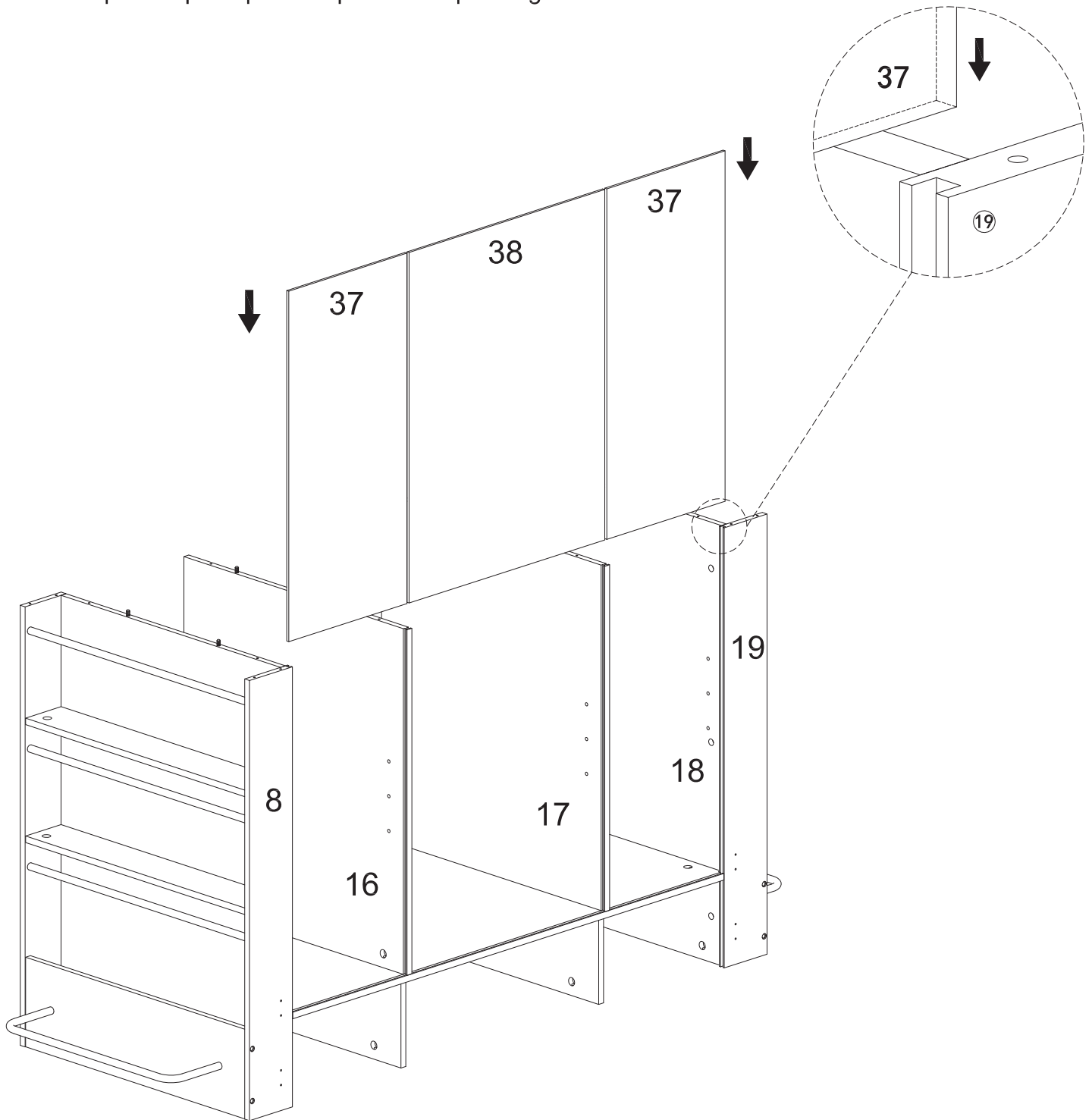

Schritt 8/Step 8/ étape 8/ passo 8/paso 8/ stap 8/steg 8/ krok 8

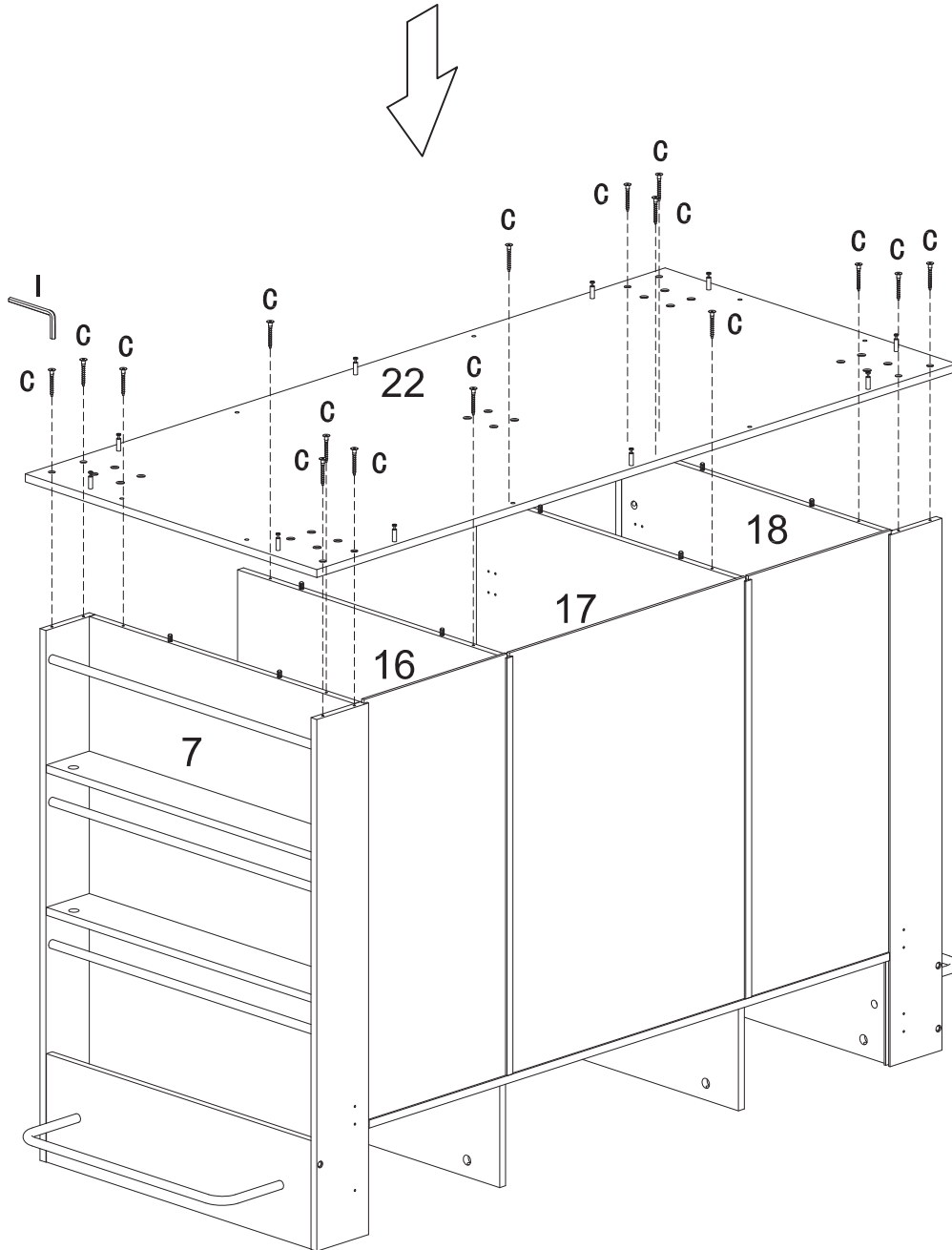
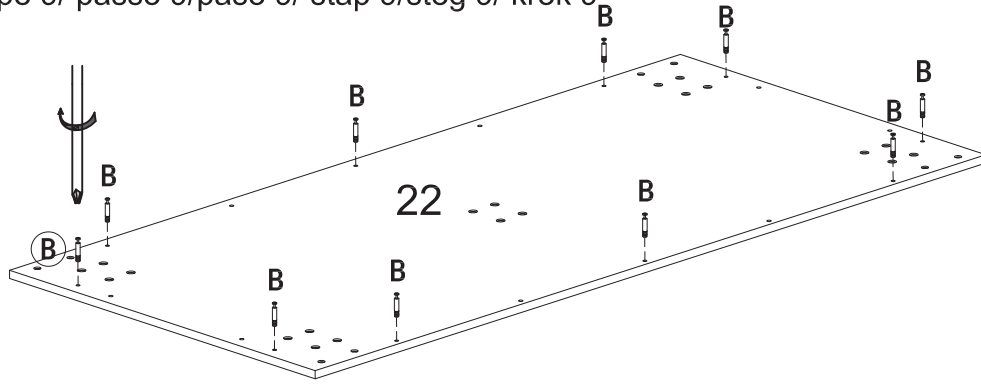

Installationsanleitung/Installation Instruction/Instruction d'installation/
 Istruzioni di installazione/Instrucciones de instalación/Installatie-instructies/
 Installationsanvisningar/Instrukcje instalacji

Schritt 9/Step 9/ étape 9/ passo 9/paso 9/ stap 9/steg 9/ krok 9





| | | |
|---|---|---|
|  |  |  |
| B x10pcs | C x16pcs | I |

Installationsanleitung/Installation Instruction/Instruction d'installation/
 Istruzioni di installazione/Instrucciones de instalación/Installatie-instructies/
 Installationsanvisningar/Instrukcje instalacji

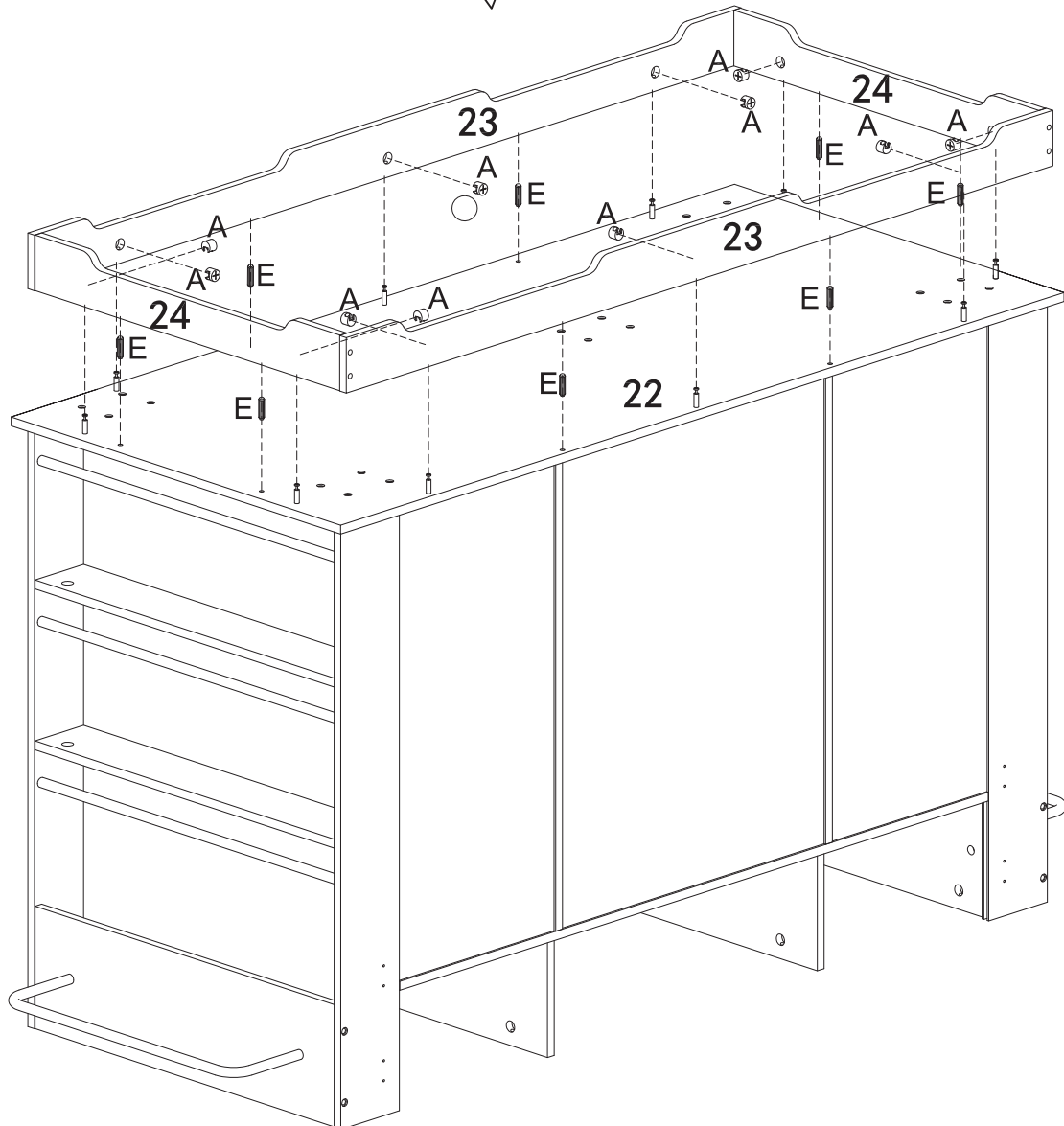
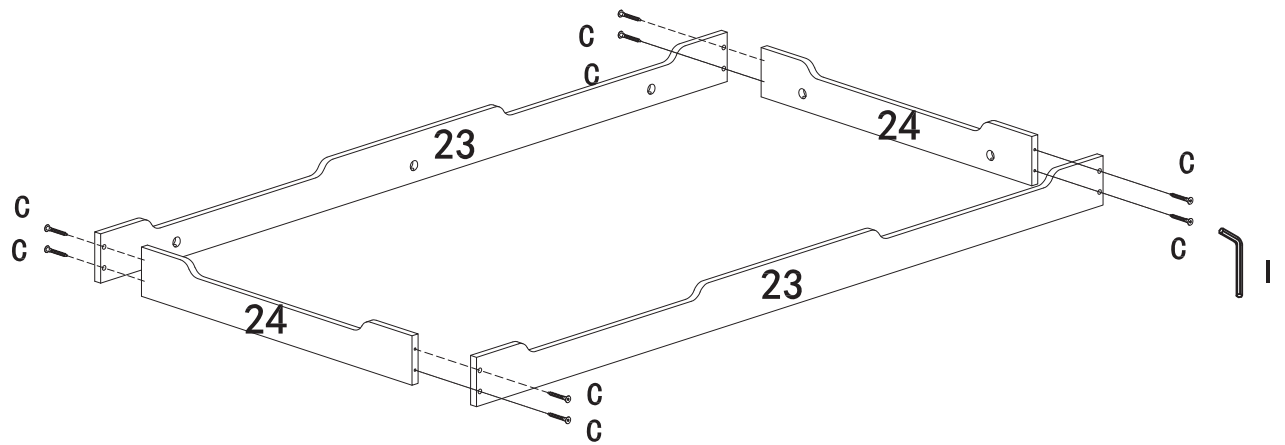
Schritt 10/Step 10/ étape 10/ passo 10/paso 10/ stap3/steg 10/ krok 10





| | | | |
|---|---|---|---|
|  |  |  |  |
| A x10pcs | E x8pcs | C x8pcs | I |

Installationsanleitung/Installation Instruction/Instruction d'installation/
Istruzioni di installazione/Instrucciones de instalación/Installatie-instructies/
Installationsanvisningar/Instrukcje instalacji

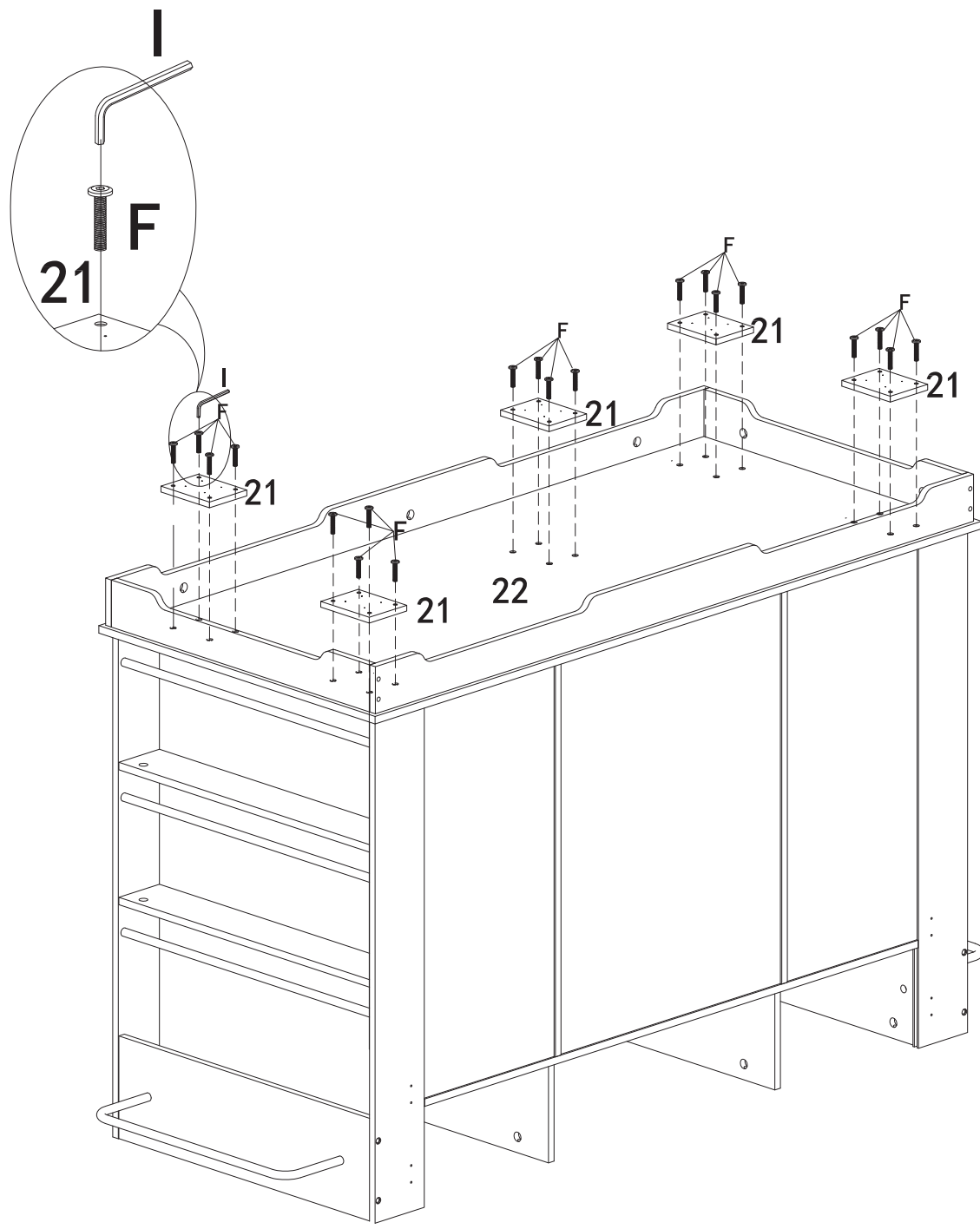
Schritt 11/Step 11/ étape 11/ passo 11/paso 11/ stap 11/steg 11/ krok 11





| | |
|---|---|
|  |  |
| F x20pcs | I |

Installationsanleitung/Installation Instruction/Instruction d'installation/
Istruzioni di installazione/Instrucciones de instalación/Installatie-instructies/
Installationsanvisningar/Instrukcje instalacji

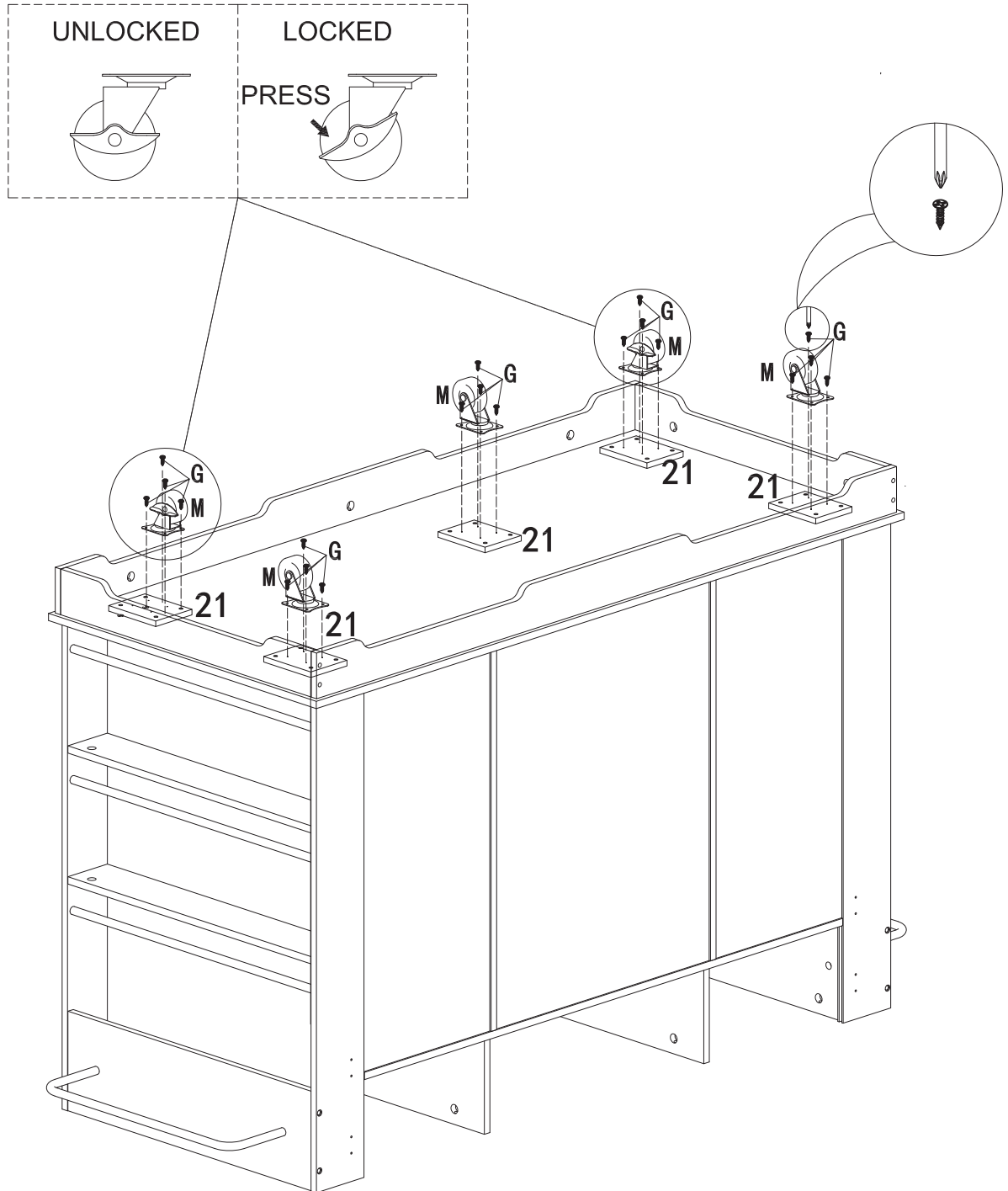
Schritt 12/Step 12/ étape 12/ passo 12/paso 12/ stap 12/steg 12/ krok 12



| | |
|---|---|
|  |  |
| G x20pcs | M x5pcs |

Installationsanleitung/Installation Instruction/Instruction d'installation/
Istruzioni di installazione/Instrucciones de instalación/Installatie-instructies/
Installationsanvisningar/Instrukcje instalacji

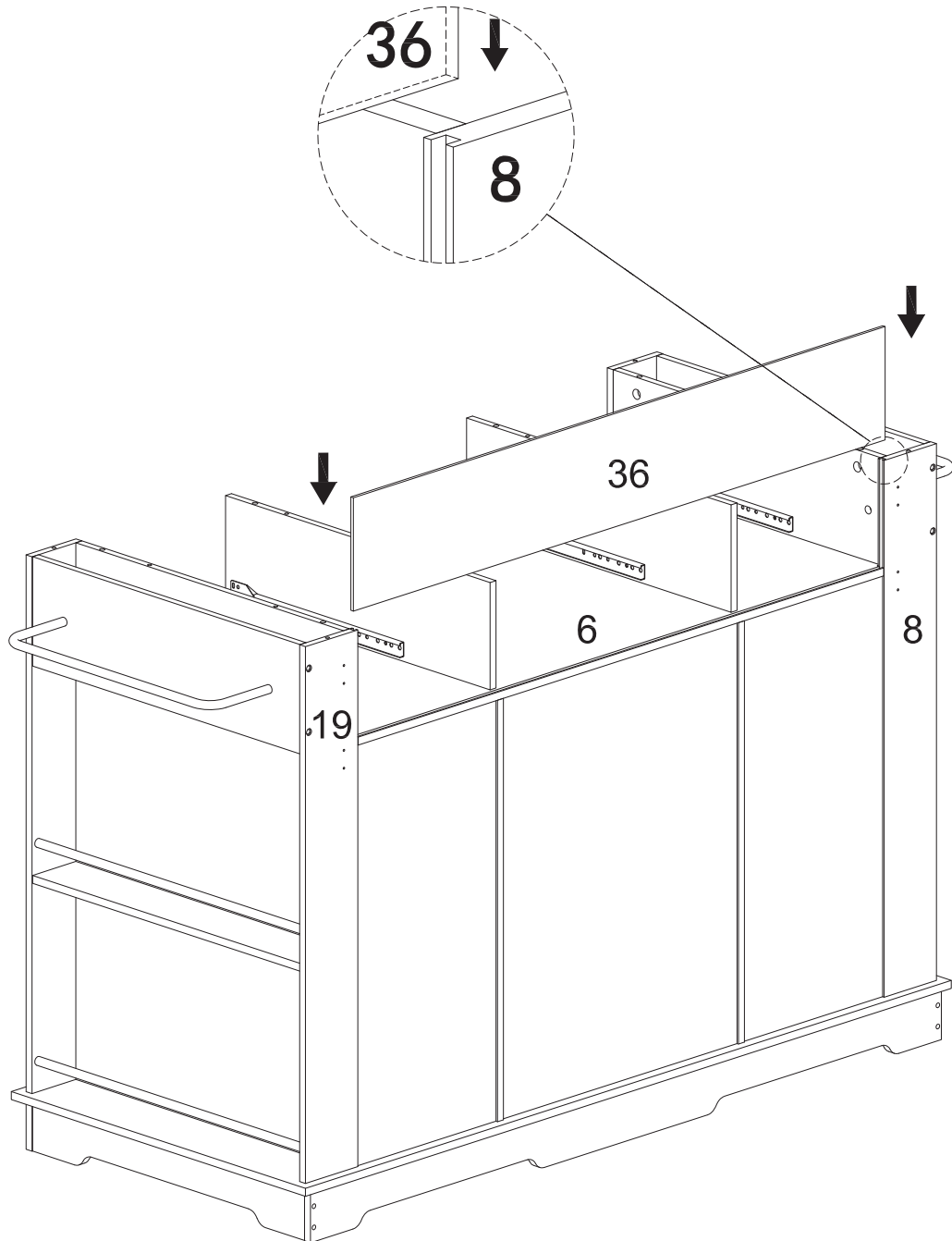

Schritt 13/Step 13/ étape 13/ passo 13/paso 13/ stap 13/steg 13/ krok 13

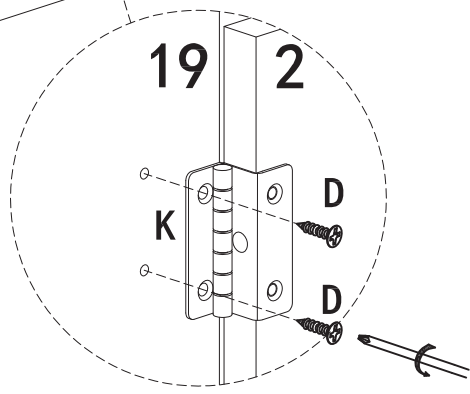
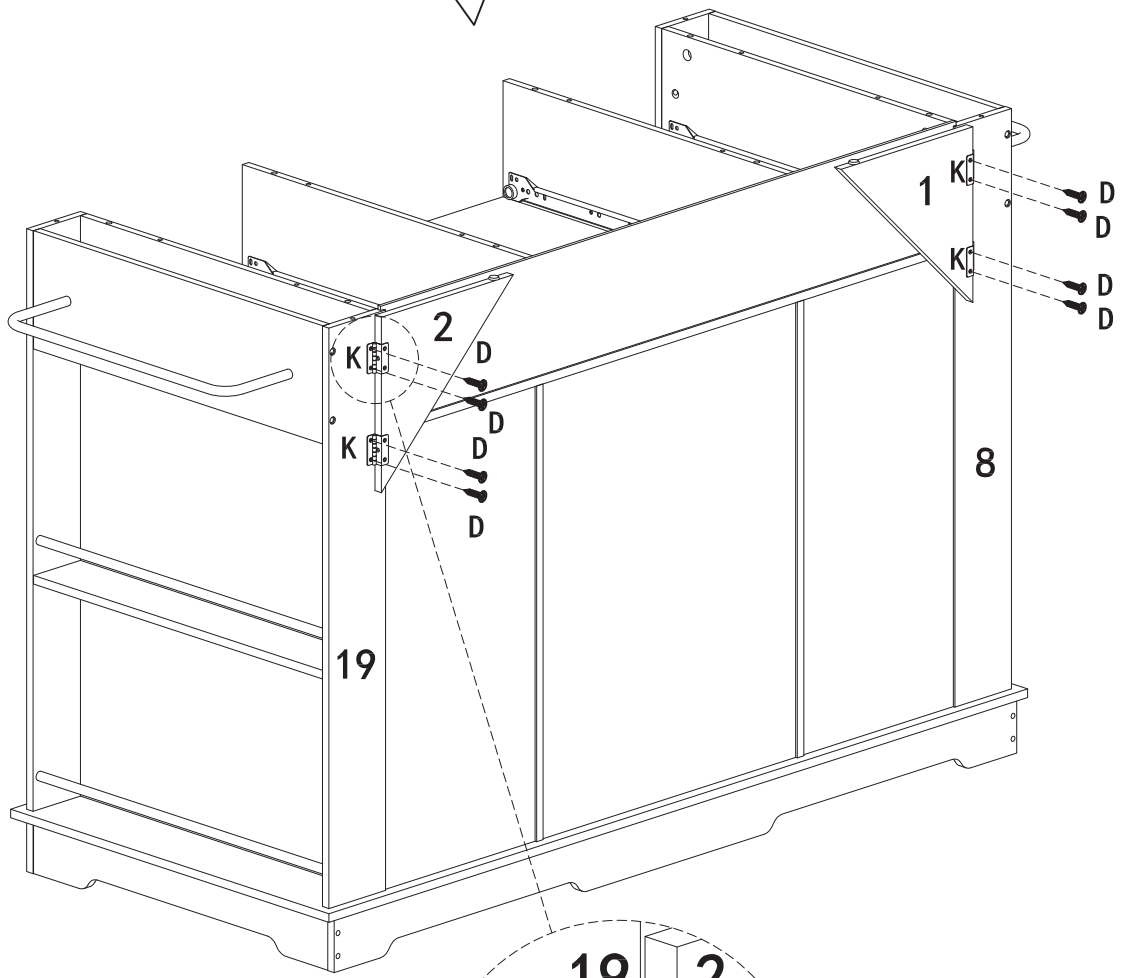
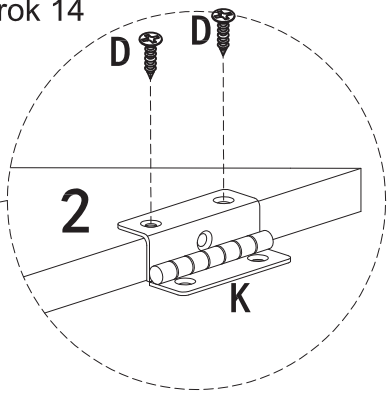
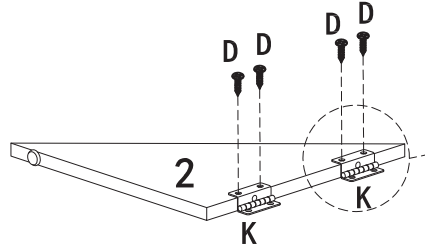
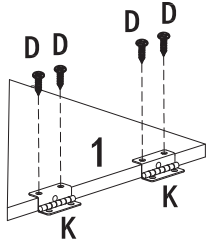

Installationsanleitung/Installation Instruction/Instruction d'installation/
 Istruzioni di installazione/Instrucciones de instalación/Installatie-instructies/
 Installationsanvisningar/Instrukcje instalacji

Schritt 14/Step 14/ étape 14/ passo 14/paso 14/ stap 14/steg 14/ krok 14





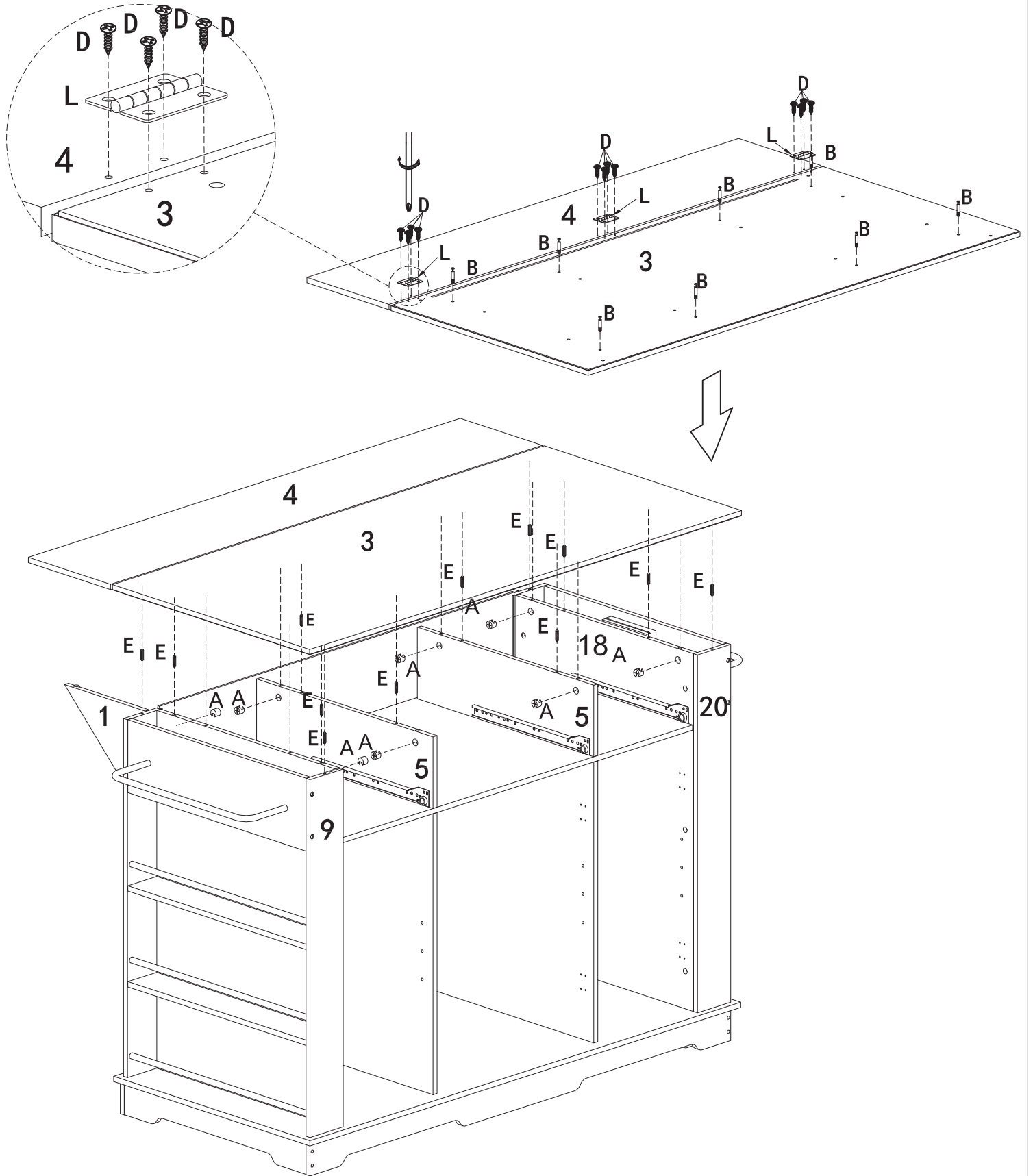

| | |
|---|---|
|  |  |
| D x16pcs | K x4pcs |

Installationsanleitung/Installation Instruction/Instruction d'installation/
 Istruzioni di installazione/Instrucciones de instalación/Installatie-instructies/
 Installationsanvisningar/Instrukcje instalacji

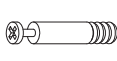
Schritt 15/Step 15/ étape 15/ passo 15/paso 15/ stap 15/steg 15/ krok 15



| | | | | |
|---|---|---|---|---|
|  |  |  |  |  |
| A x8pcs | B x8pcs | D x12pcs | E x12pcs | L x3pcs |

Installationsanleitung/Installation Instruction/Instruction d'installation/
 Istruzioni di installazione/Instrucciones de instalación/Installatie-instructies/
 Installationsanvisningar/Instrukcje instalacji

Schritt 16/Step 16/ étape 16/ passo 16/paso 16/ stap 16/steg 16/ krok 16

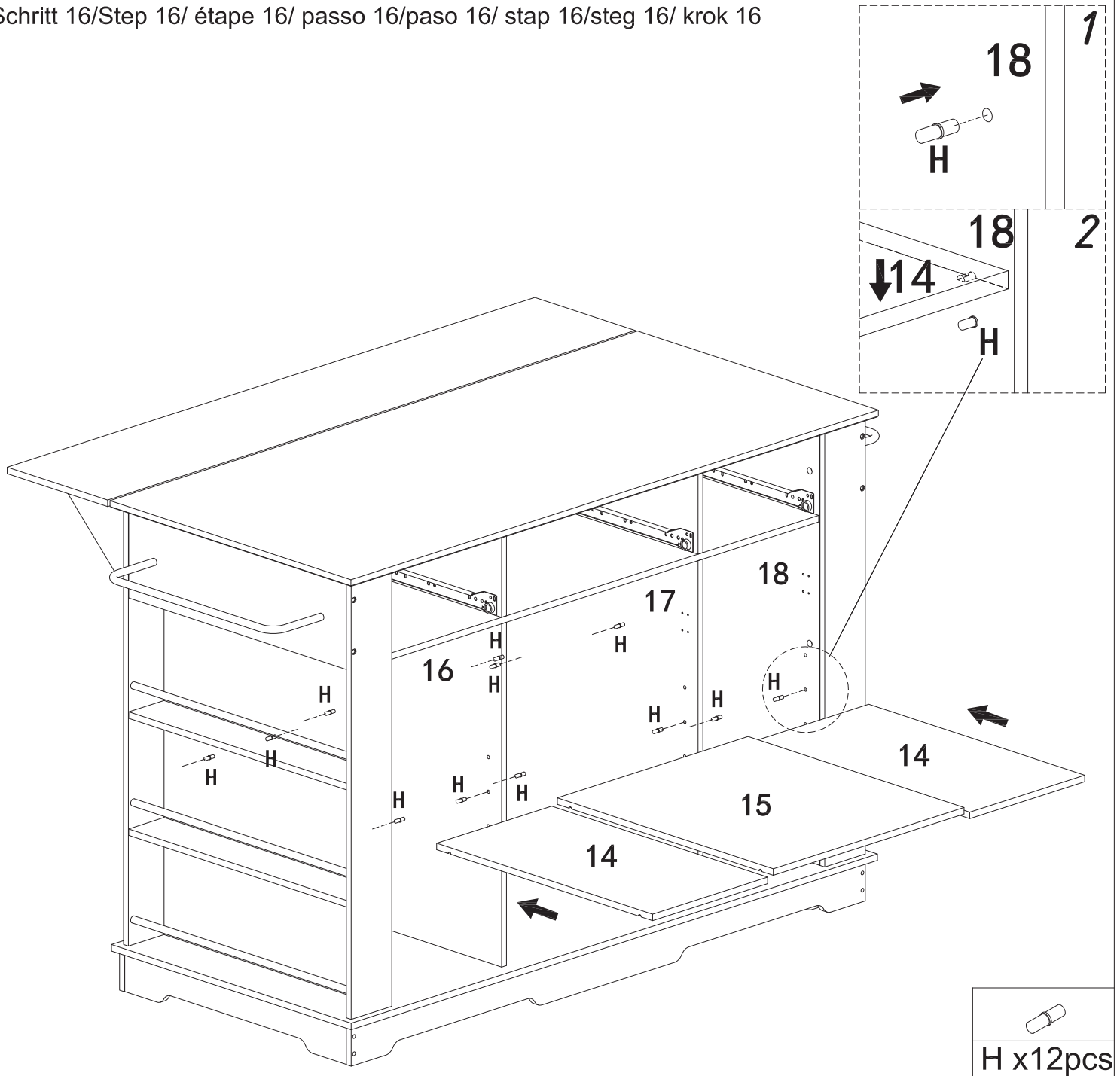



 H x12pcs

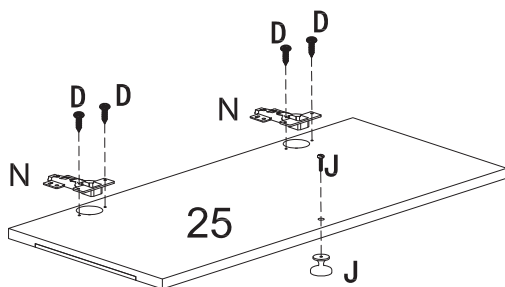

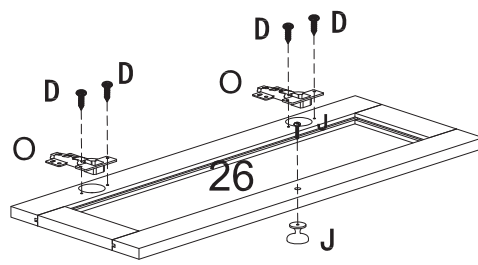

Schritt 17/Step 17/ étape 17/ passo 17/paso 17/ stap 17/steg 17/ krok 17



X 2PCS



X 2PCS

| | | | |
|---|--|---|---|
|  |  |  |  |
| D x16pcs | J x4pcs | N x4pcs | O x4pcs |

Installationsanleitung/Installation Instruction/Instruction d'installation/
 Istruzioni di installazione/Instrucciones de instalación/Installatie-instructies/
 Installationsanvisningar/Instrukcje instalacji

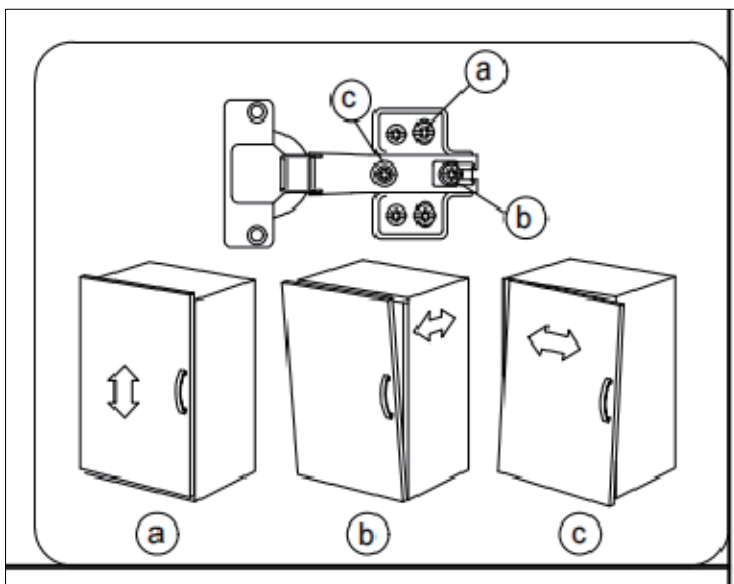
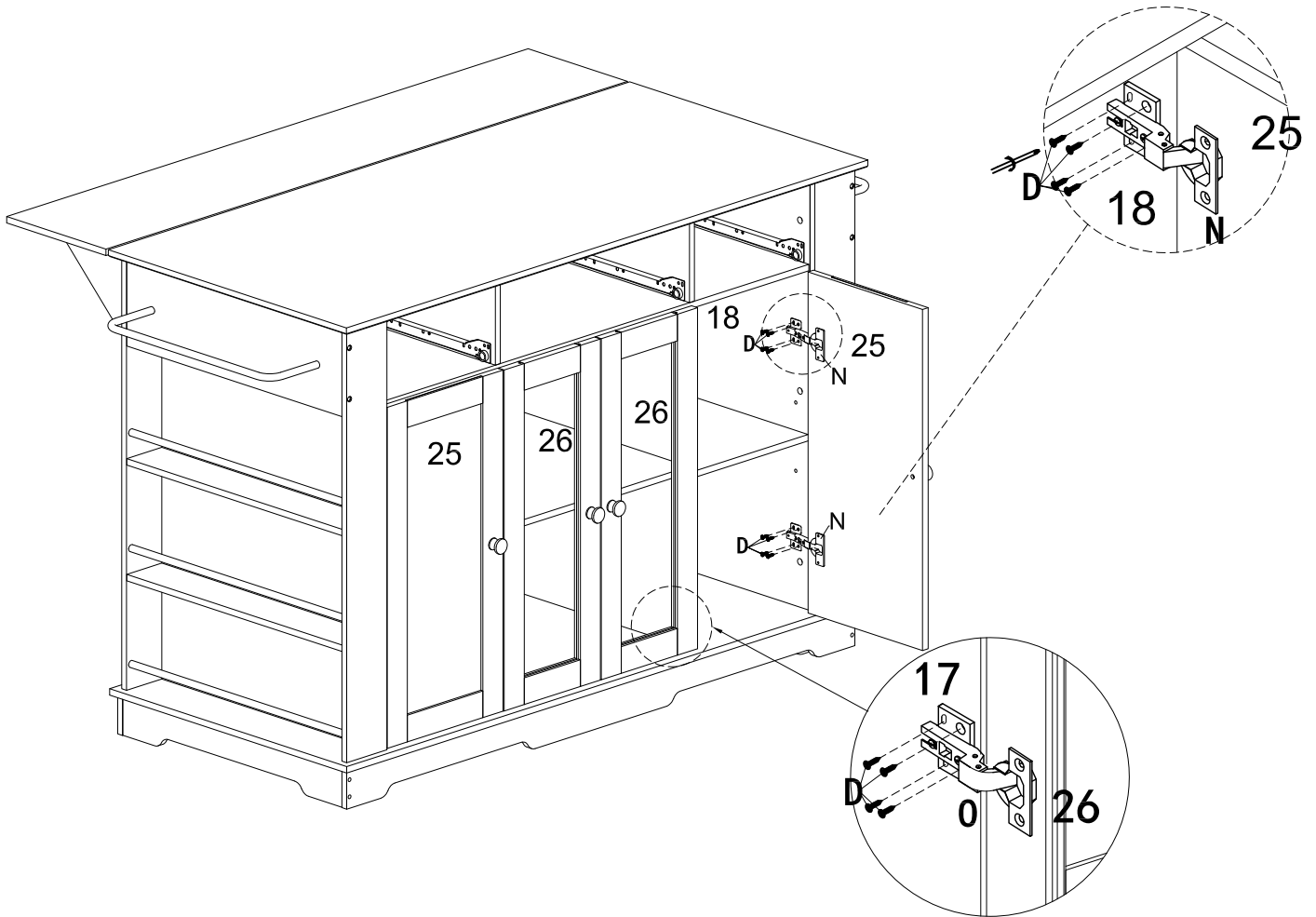

Schritt 18/Step 18/ étape 18/ passo 18/paso 18/ stap 18/steg 18/ krok 18

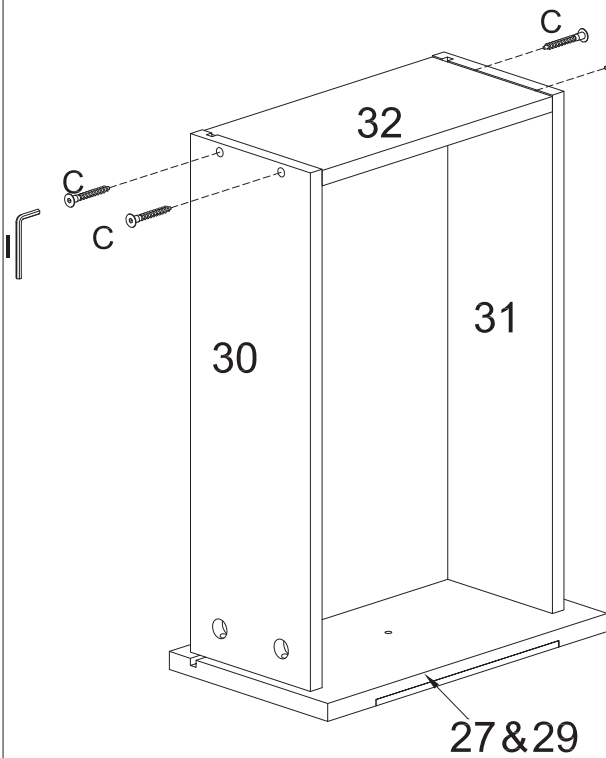
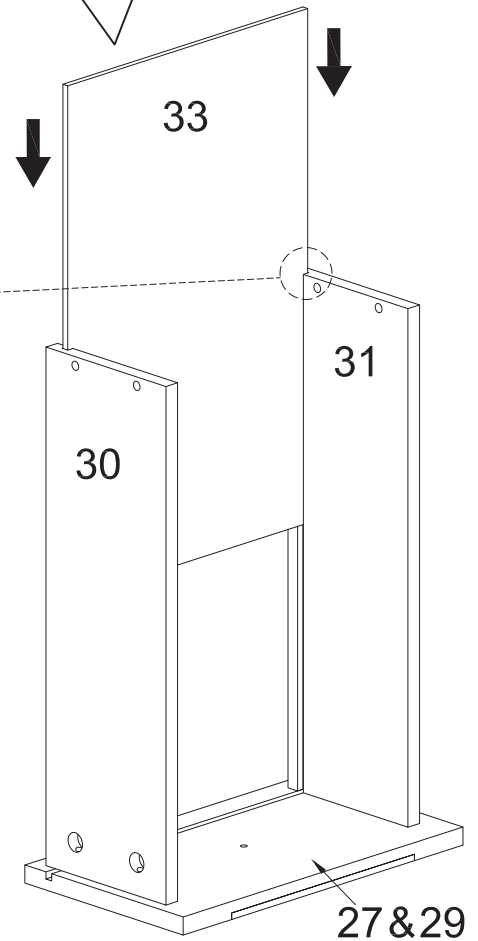
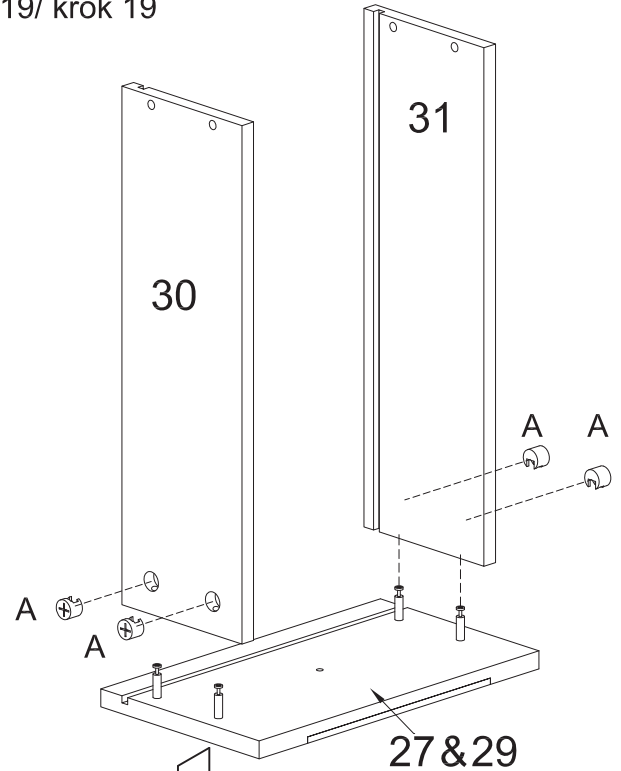
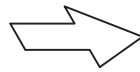
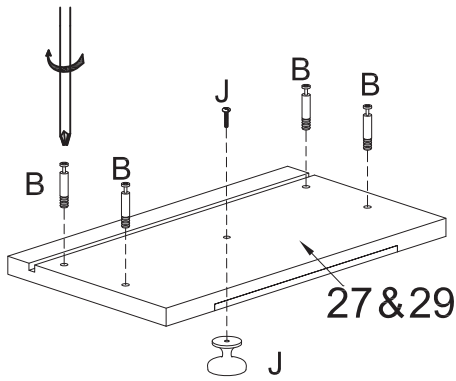

Installationsanleitung/Installation Instruction/Instruction d'installation/
 Istruzioni di installazione/Instrucciones de instalación/Installatie-instructies/
 Installationsanvisningar/Instrukcje instalacji

Schritt 19/Step 19/ étape 19/ passo 19/paso 19/ stap 19/steg 19/ krok 19

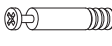
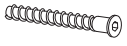



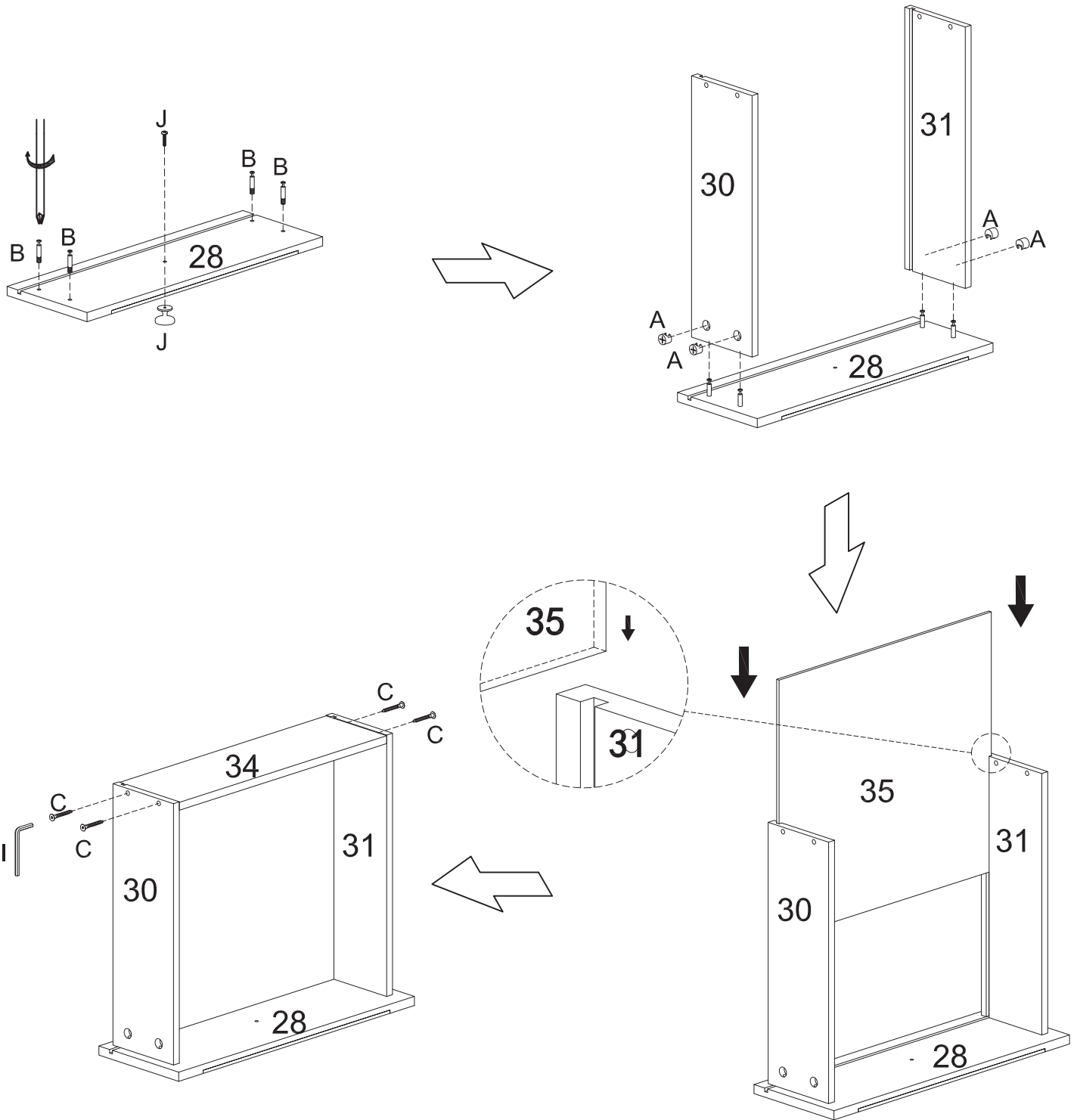

| | | | | |
|---|---|---|---|---|
|  |  |  |  |  |
| A x8pcs | B x8pcs | C x8pcs | I | J x2pc |

Installationsanleitung/Installation Instruction/Instruction d'installation/
 Istruzioni di installazione/Instrucciones de instalación/Installatie-instructies/
 Installationsanvisningar/Instrukcje instalacji

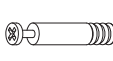
Schritt 20/Step 20/ étape 20/ passo 20/paso 20/ stap 20/steg 20/ krok 20





| | | | | |
|---|---|---|---|---|
|  |  |  |  |  |
| A x4pcs | B x4pcs | C x4pcs | I | J x1pc |

Installationsanleitung/Installation Instruction/Instruction d'installation/
 Istruzioni di installazione/Instrucciones de instalación/Installatie-instructies/
 Installationsanvisningar/Instrukcje instalacji

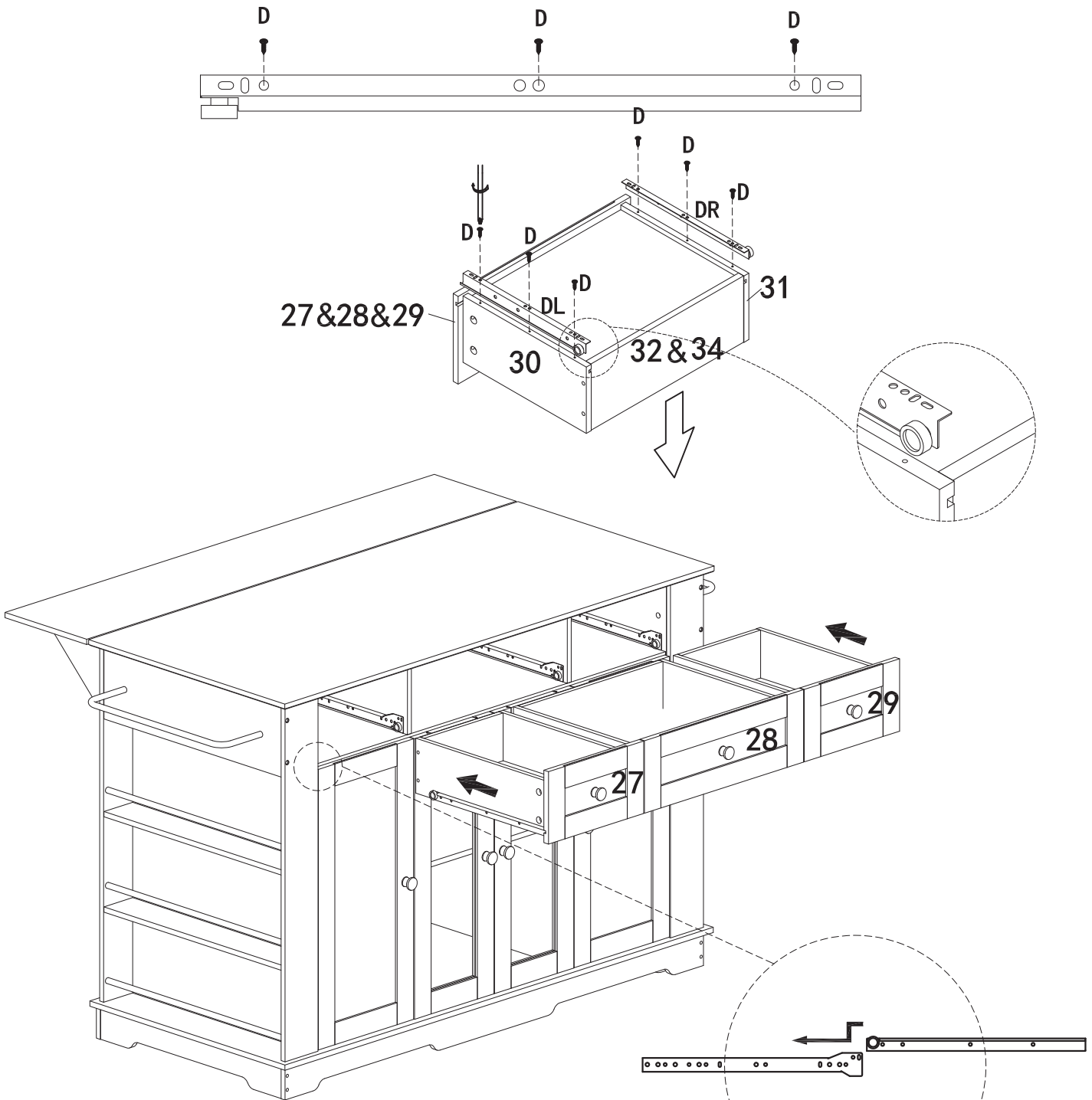
Schritt 21/Step 21/ étape 21/ passo 21/paso 21/ stap 21/steg 21/ krok 21



Installation abgeschlossen
 Installation Completed
 Installation terminée
 Installazione completata
 Instalación finalizada
 Installatie voltooid
 Installation slutförd
 Instalacja zakończona

| | |
|---|--|
|  |  DLx3 DRx3 |
| D x18pcs | P x3pcs |